

TECHNICAL BULLETIN

Subject:

Bin Piping Installation Guide

Bulletin #:

110993

Rev:

F

Created by:

JMB

Date:

10/14/2021

ECR #

97607

Production: -

Service: x

Sales: x

Product Lines: Transportation Equipment: - Agri-vac/Pneumatic Equipment: x

The purpose of this document is to provide the reader with instructions on installation of bin piping for you with Walinga Pneumatic Conveying Systems.

If you have any questions about an installation, please do not hesitate to contact your Walinga representative.

1. Please refer to the last page of this technical bulletin to familiarize yourself with the piping components and a typical installation.
2. Items to note:
 - a. All of the piping components (tubing and elbows) must have the same internal diameter. Any lips or edges will result in a decrease in conveying performance, premature piping wear, and commodity damage).
 - b. All joints should be perfectly mated. Failure to do this will result in premature piping wear and commodity damage.
 - c. Piping should not be installed on an angle unless it is within 25' of the discharge point. For example, running a pipe on an angle along to roof line of a bin is acceptable.
 - d. All pipes should be installed vertically (straight up or down) or straight along the ground.
 - e. There should be 20' of piping between all elbows. Failure to do this will result in a reduction of conveying capacity.

Head Office

R.R.#5, Guelph, ON
Canada N1H 6J2
Tel (519) 824-8520
Fax (519) 824-5651

938 Glengarry Cr

Fergus, Ontario
Canada N1M 2W7
Tel (519) 787-8227
Fax (519) 787-8210

70 3rd Ave. N.E. Box 1790

Carman, Manitoba
Canada R0G 0J0
Tel (204) 745-2951
Fax (204) 745-6309

1190 Electric Ave.

Wayland, MI.
U.S.A. 49348
Tel (800) 466-1197
Fax (616) 877-3474

TECHNICAL BULLETIN

Subject:

Bin Piping Installation Guide

Bulletin #:

110993

Rev:

F

Created by:

JMB

Date:

10/14/2021

ECR #

97607

Production: -

Service: x

Sales: x

Product Lines: Transportation Equipment: - Agri-vac/Pneumatic Equipment: x

3. Determine location of pipe on bin wall.
 - a. Confirm that there are no obstacles, such as vents and doors.
4. Install standoff brackets (using 3/8" bolts or riv-nuts) with the long arm up. The first two locations should be approximately 12" below the eve and 60" from the ground.



TECHNICAL BULLETIN

Subject:

Bin Piping Installation Guide

Bulletin #:

110993

Rev:

F

Created by:

JMB

Date:

10/14/2021

ECR #

97607

Production:

Service:

Sales:

Product Lines: Transportation Equipment: Agri-vac/Pneumatic Equipment:

5. Install the remaining brackets equally spaced (using 3/8" bolts or riv-nuts), at a maximum of 15' apart.

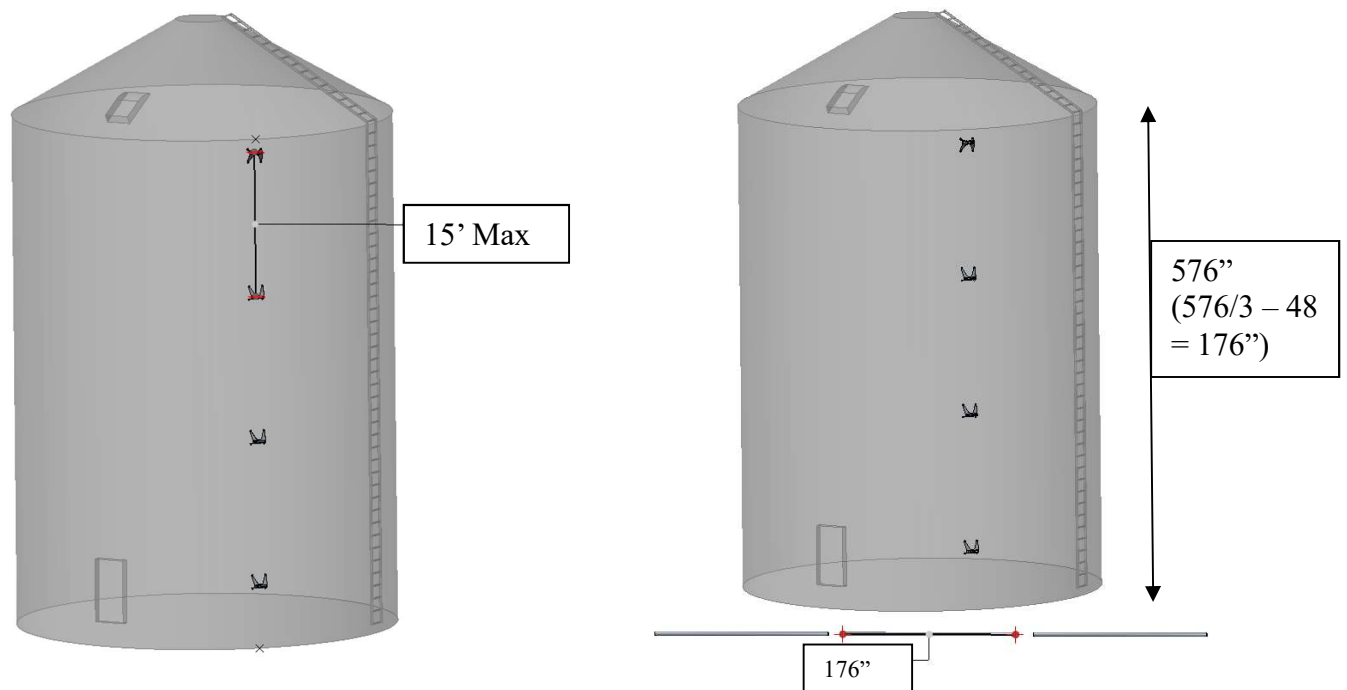

6. Cut or assemble vertical pipe at to the required length.
- Measure the ground to the eve, and subtract 48".
 - Install compression couplings as needed. To ensure proper seating of the inner sleeve and gasket, partially tighten the bolts in a uniform manner until the correct torque rating is achieved (see point 14). At this point the flanges of the coupling should be touching.

TECHNICAL BULLETIN

Subject:

Bin Piping Installation Guide

Bulletin #:

Rev:

Created by:

Date:

110993 F

JMB

10/14/2021

ECR # 97607

Production: -

Service: x

Sales: x

Product Lines: Transportation Equipment: -

Agri-vac/Pneumatic Equipment: x

7. Cut elbows as follows:

- Run a measuring tape along outside radius of elbow, divide by 3 and cut into two pieces, $1/3 - 2/3$.
- Elbow should end up as a 30° elbow and 60° elbow.
- Walinga offers 60° & 30° elbows (TB:111827)

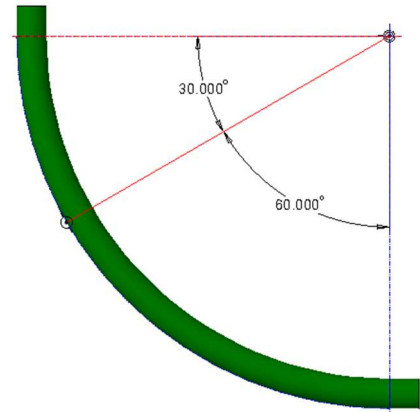

8. Install long elbow (60°) on the assembled vertical pipe.

- Connect the cut side of the elbow to your bin pipe with a compression coupler. To ensure proper seating of the inner sleeve and gasket, partially tighten the bolts in a uniform manner until the correct torque rating is achieved (see point 14). At this point the flanges of the coupling should be touching.
- Reference TB:110784 - It is important that the flange is installed on the discharge end of the elbow



TECHNICAL BULLETIN

Subject:

Bin Piping Installation Guide

Bulletin #:

110993

Rev:

F

Created by:

JMB

Date:

10/14/2021

ECR #

97607

Production: -

Service: x

Sales: x

Product Lines: Transportation Equipment: -

Agri-vac/Pneumatic Equipment: x

9. Proceed to install pipe with elbow on the bin.
 - a. Point elbow towards the lid.
 - b. The coupling which joins elbow and pipe together should be approximately even with the roof eve.
 - c. Leave saddle clamps semi loose so pipe can be adjusted as required later.

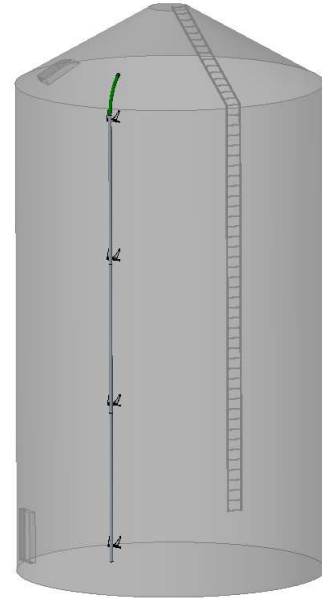

10. Install cyclone.
 - a. Cut hole into the lid.
 - b. Use silicone to seal.
 - c. Cyclone to be oriented towards the vertical elbow.

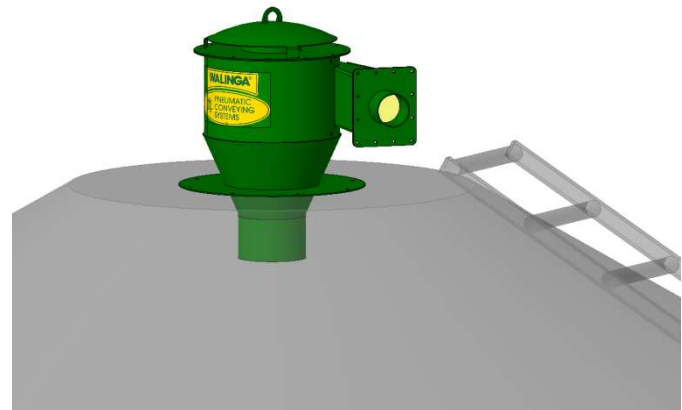

TECHNICAL BULLETIN

Subject:

Bin Piping Installation Guide

Bulletin #:

110993

Rev:

F

Created by:

JMB

Date:

10/14/2021

ECR #

97607

Production: -

Service: x

Sales: x

Product Lines: Transportation Equipment: - Agri-vac/Pneumatic Equipment: x

11. Install short elbow (30°) on cyclone with the cut end facing away from the cyclone.
 - a. To ensure proper seating of the inner sleeve and gasket, partially tighten the bolts in a uniform manner until the correct torque rating is achieved (see point 14). At this point the flanges of the coupling should be touching.



12. Line up lower elbow and upper elbow.
 - a. Ensure that the elbows are square.

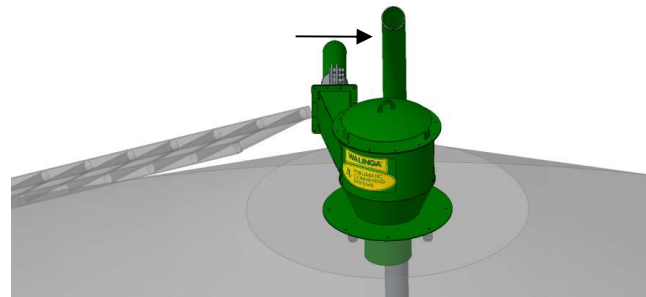

13. Measure in between the two elbows and install the pipe.

14. When completed, tighten and ensure that all nuts are sufficiently tight. To ensure proper seating of the inner sleeve and gasket, partially tighten the bolts in a uniform manner until the correct torque rating is achieved (see point 14). At this point the flanges of the coupling should be touching.

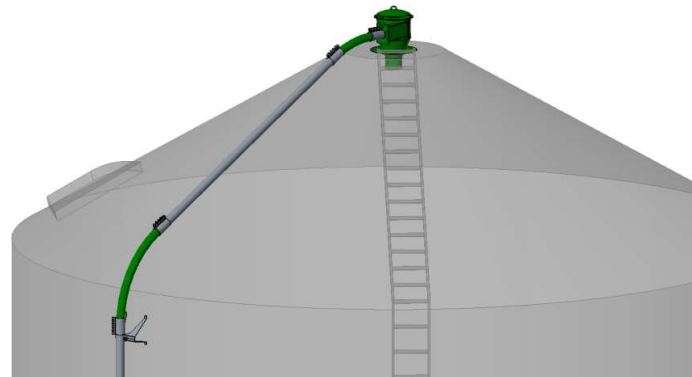

TECHNICAL BULLETIN

Subject:

Bin Piping Installation Guide

Bulletin #:

110993

Rev:

F

Created by:

JMB

Date:

10/14/2021

ECR #

97607

Production: -

Service: x

Sales: x

Product Lines: Transportation Equipment: - Agri-vac/Pneumatic Equipment: x

15. Walinga recommends that a wide radius elbow, (rather than a flex hose) is used to connect the bin piping to the horizontal piping. When installing the wide radius elbow, special attention should be made to ensure that the pipe and elbow have the exact same profile. These elbows are manufactured with an acceptable tolerance (1/16" to 1/8th out of round) that can cause premature wear if it is not addressed during installation. The process to address this issue is as follows:

- a. Apply an installation line on the tube and elbow that allows the tube and elbow to mate tight to each other (refer to picture below)
- b. Apply a penetrating oil to the compression coupling bolt threads
- c. Partially tighten the each of the bolts one by one and just a little bit at a time
- d. Complete this sequence ten times
- e. There should be approximately 3/4" of exposed bolt thread (refer to picture below)



16. Ensure that all of the compression couplings are torqued to the correct rating. To ensure proper seating of the inner sleeve and gasket, partially tighten the bolts in a uniform manner until the correct torque rating is achieved. At this point the flanges of the coupling should be touching.

- a. 5/16" nuts @ 12 ft/lbs
- b. 1/2" nuts @ 45 ft/lbs
- c. 5/8" nuts @ 65 ft/lbs
- d. 3/4" nuts @ 95 ft/lbs

Head Office

R.R.#5, Guelph, ON
Canada N1H 6J2
Tel (519) 824-8520
Fax (519) 824-5651

938 Glengarry Cr

Fergus, Ontario
Canada N1M 2W7
Tel (519) 787-8227
Fax (519) 787-8210

70 3rd Ave. N.E. Box 1790

Carman, Manitoba
Canada R0G 0J0
Tel (204) 745-2951
Fax (204) 745-6309

1190 Electric Ave.

Wayland, MI.
U.S.A. 49348
Tel (800) 466-1197
Fax (616) 877-3474

TECHNICAL BULLETIN

Subject:

Bin Piping Installation Guide

Bulletin #:

110993

Rev:

F

Created by:

JMB

Date:

10/14/2021

ECR #

97607

Production: -

Service: x

Sales: x

Product Lines: Transportation Equipment: -

Agri-vac/Pneumatic Equipment: x

Typical Set-Up



Page 8 of 9

Bulletin #:

110993F

Head Office

R.R.#5, Guelph, ON
Canada N1H 6J2
Tel (519) 824-8520
Fax (519) 824-5651

938 Glengarry Cr

Fergus, Ontario
Canada N1M 2W7
Tel (519) 787-8227
Fax (519) 787-8210

70 3rd Ave. N.E. Box 1790

Carman, Manitoba
Canada R0G 0J0
Tel (204) 745-2951
Fax (204) 745-6309

1190 Electric Ave.

Wayland, MI.
U.S.A. 49348
Tel (800) 466-1197
Fax (616) 877-3474

TECHNICAL BULLETIN

Subject:

Bin Piping Installation Guide

Bulletin #:

110993

Rev:

F

Created by:

JMB

Date:

10/14/2021

ECR #

97607

Production: -

Service: x

Sales: x

Product Lines: Transportation Equipment: - Agri-vac/Pneumatic Equipment: x

Typical Piping Components

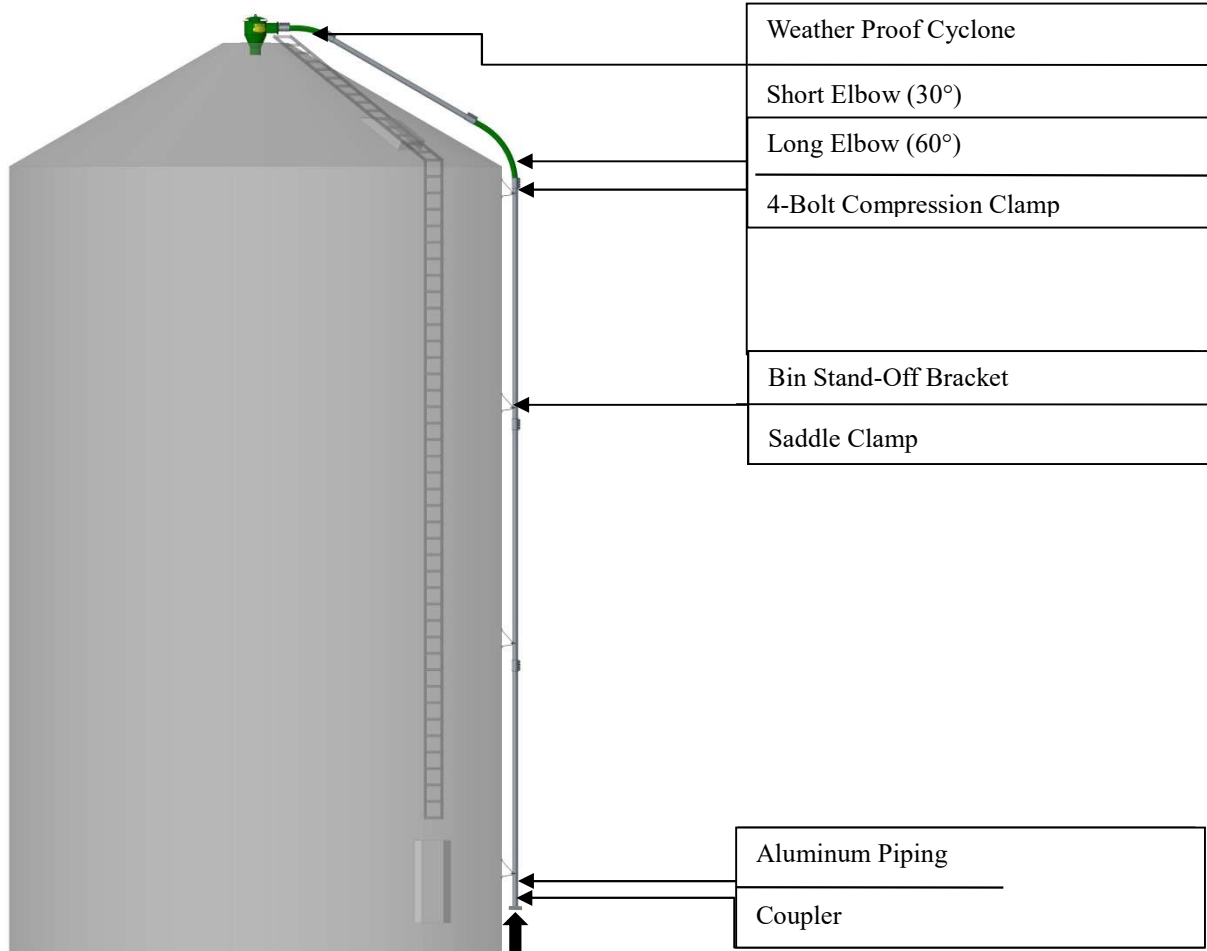

To maximize efficiency and longevity, Walinga Recommends using a wide CLR elbow rather than a flex hose.