

Ultra-Veyor

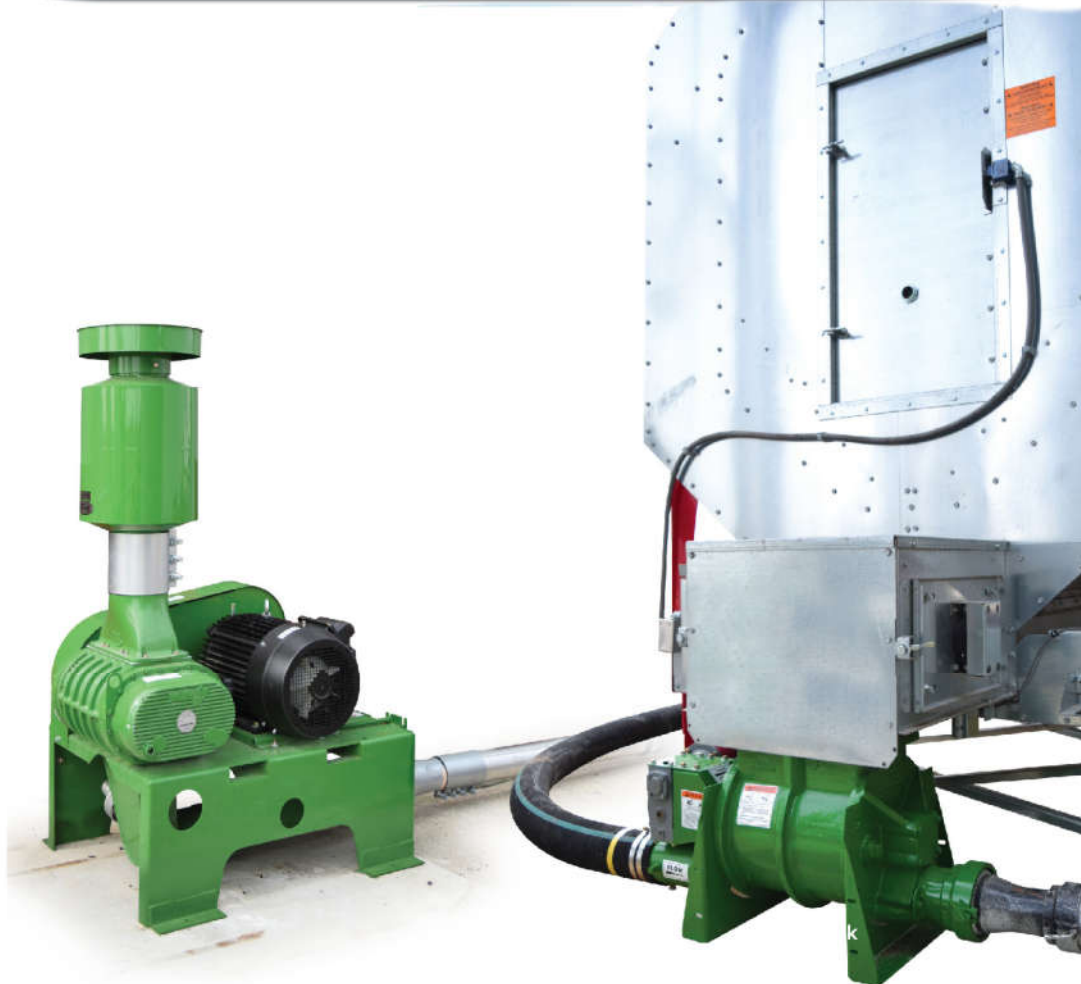

ULTRA-VEYOR SYSTEM OPERATOR'S MANUAL



TOUGH TO BEAT IN THE LONG RUN

ULTRA-VEYOR SYSTEM

Warranty Registration Form & Inspection Report

WARRANTY REGISTRATION (3 part form - please print)		
<i>This form must be filled out by the dealer and signed by both the dealer and the customer at the time of delivery.</i>		
<i>Delivery Date: mm / dd / yyyy</i>		
<i>COMPANY / CUSTOMER NAME</i>		<i>DEALER NAME</i>
<i>Phone:</i>		<i>Phone</i>
<i>Mobile phone:</i>		<i>Mobile phone</i>
<i>Email: @</i>		<i>Email: @</i>
<i>StreetAddress:</i>		<i>StreetAddress</i>
<i>City: Prov/State</i>		<i>City: Prov/State</i>
<i>Postal/Zip Country</i>		<i>Postal/Zip Country</i>
<i>Machine Serial Number</i>	<i>Blower Serial No.</i>	<i>Airlock Serial Number</i>

DEALER INSPECTION REPORT		SAFETY	
<input type="checkbox"/>	Blower and Airlock Turn Freely	<input type="checkbox"/>	Guards Installed and Secured
<input type="checkbox"/>	Airline Connections Tight	<input type="checkbox"/>	All Safety Signs Installed
<input type="checkbox"/>	Airline Intake Caps Secured	<input type="checkbox"/>	Review Operating and Safety Instructions
<input type="checkbox"/>	Drive Chains and Belts Tensioned and Aligned	<input type="checkbox"/>	Operating Manual Supplied
<input type="checkbox"/>	Lubricate Machine		
<input type="checkbox"/>	Check Oil Level in Reservoirs		

I have thoroughly instructed the buyer on the above described equipment which review included the Operator's Manual content, equipment care, adjustments, safe operation and applicable warranty policy.

Date _____ Dealer's Rep. Signature _____

The above equipment and Operator's Manual have been received by me and I have been thoroughly instructed as to care, adjustments, safe operation and applicable warranty policy.

Date _____ Owner's Signature _____

WHITE	YELLOW	PINK
WALINGA	DEALER	CUSTOMER

3 Part Form Please Print

Dear Customer,

Thank you for choosing WALINGA PNEUMATIC CONVEYING SYSTEMS. For your convenience, should you require any information related to Parts, Service or Technical Engineering, please contact one of the following Walinga Personnel in Guelph at 1-888 925-4642 unless noted

TECHNICAL - ENGINEERING:

Duane Swaving 226-979-8227 duane.swaving@walinga.com

Ken Swaving 519 787-8227 (ext:100) ks@walinga.com

WARRANTY CLAIMS:

Canada: (ext:258) warranty.can@walinga.com

USA: (800) 466-1197 (ext 8) warranty.usa@walinga.com

SERVICE MANAGER:

Andy Nijenhuis (519) 763-7000 (ext:260) andy@walinga.com

SALES MANAGER:

Canada: Tom Linde (519) 787-8227 (ext 5) thl@walinga.com

USA: Peter Kingma (800) 466-1197 jpk@walinga.com

ORIGINAL PARTS SALES:

Ontario and Eastern Canada:

Scott Lodder spl@walinga.com (ext: 224) Parts Department Fax: (519) 824-0367

Manitoba and Western Canada:

Chad Yeo 204-745-2951 chad.yeo@walinga.com

USA:

John VanMiddlekoop (800) 466-1197 (ext 3) jvm@walinga.com

CORPORATE HEAD OFFICE:

5656 Highway 6N

RR#5, Guelph, Ontario Canada N1H 6J2

Tel: (888) 925-4642 Fax: (519) 824-5651

FACTORY DISTRIBUTION AND SERVICE CENTRES:

938 Glengarry Cres. Fergus, Ontario Canada N1M 2W7

Tel: (519) 787-8227 Fax: (519) 787-8210

1190 Electric Ave. Wayland, MI.USA 49348

Tel (800) 466-1197 Fax (616) 877-3474

70 3rd Ave. N.E. Box 1790 Carman, Manitoba Canada R0G 0J0

Tel (204) 745-2951 Fax (204) 745-6309

Customvac Australia

24 Molloy Street Toowoomba, Queensland Australia 4350

Tel 1 800 242-699

Walinga Inc.

Pneumatic Conveying System

Warranty Terms

Walinga Inc. is committed to providing a quality product that will meet or exceed your expectations for many years to come. Our warranty terms and our warranty claim process has been designed to ensure that each warranty claim will be resolved in an orderly, fair and timely manner.

The Warranty

Walinga Inc. (“Walinga”) warrants that all new pneumatic products sold by Walinga Inc. will be free from defects in material and workmanship (the “Walinga Warranty”).

Warranty Period

The warranty period for the Walinga Warranty shall expire on the date that is the earlier of: two (2) years after the date of delivery to the original customer; or upon the expiration of five hundred (500) hours of operation; whichever date comes first.

Limitations of and exclusions from the Walinga Warranty

- The Walinga Warranty applies to material and workmanship only.
- With respect to any component parts that are supplied or manufactured by others, the warranty coverage on such component parts will be strictly limited to the warranties of the manufacturers of such component parts.
- The Walinga Warranty shall only be for the benefit of the original purchaser of the pneumatic products.
- A Walinga Warranty may be transferable by the original purchaser to a third party for the balance of the warranty period then remaining, provided that Walinga consents in writing to such transfer of warranty.
- The Walinga Warranty is conditional upon proper storage, installation, use, maintenance, operation and compliance with any applicable recommendations of Walinga.

Warranty Claim Procedure

Should you encounter any difficulties with your unit within its warranty period, please contact your local Walinga dealer or sales representative, your local Walinga Service department or Walinga’s Warranty Department to submit a warranty claim application.

To speak with a Walinga Warranty Coordinator, contact:

- Canada
International 1-888-WALINGA (ext 273)
 +1-519-824-8520 (ext 273)
 Email – warranty.canada@walinga.com
- USA
 1-800-466-1197 (ext 8)
 Email – warranty.usa@walinga.com
- Australia
 07-4634-7344
 Email – mail@customvac.com.au

Required Warranty Claim information

The following information must be provided to Walinga in order for us to properly process and consider your warranty application:

- Customer name and contact information (email if available).
- The equipment serial number and/or Vehicle Identification Number (if applicable).
- Date of claimed failure.
- Equipment hours of operation.
- Details, description and photos (upon request) of the claimed failure and the corrective repairs attempted.

Warranty Conditions

- **Equipment must be registered within 30 days of being received by the buyer. It will be within the sole and unfettered discretion of Walinga as to whether it will honour its warranty on non-registered equipment.**

Warranty Conditions (continued)

- The buyer is responsible for promptly notifying Walinga of any defects to the equipment. The buyer is also responsible for making the equipment available to Walinga or its authorized repair facility for evaluation and repair.
- Prior to making any repairs or parts replacements, a warranty application and any estimated associated costs must be approved with the issuance of a claim number by an authorized Walinga representative. Undertaking any work prior to receiving warranty authorization may result in a partial or complete loss of warranty coverage.
- At Walinga's discretion, warranty repairs may be authorized to be completed at a repair facility convenient to the buyer. In such situations the estimated labour time must be approved by Walinga prior to undertaking any work. Labour hours will be reimbursed at the facilities posted hourly labour rate.
- At Walinga's request, parts in question must be returned to the nearest Walinga service facility for evaluation. In such situations a Returned Goods Authorization (RGA) number will be provided to the buyer. The returning shipment must be clearly labeled with the assigned RGA number and include a copy of the RGA form. Unless otherwise arranged, these parts are to be returned to Walinga within 30 days to ensure timely processing of your warranty claim. Failure to return such parts may result in partial or complete loss of warranty coverage.
- Replacement parts provided under warranty are covered for the remainder of the original equipment warranty period.
- Walinga reserves the right to use new, remanufactured or refurbished components when performing warranty repairs and replacements.
- Walinga is entitled to a reasonable amount of time and a reasonable number of attempts to assess the claim, diagnose the problem, and perform any necessary repairs.
- The warranty offered on used or refurbished equipment is limited to that specified on the purchase contract. Where a warranty period has not been stipulated on the purchase contract., and where such equipment is "used", then such equipment is considered by Walinga to be sold "as is, where is" without the Walinga Warranty. Where such equipment is refurbished, then the Walinga Warranty shall apply.

Without limitation, Walinga reserves the right to reject a warranty claim or for any one or more of the following reasons:

- The warranty claim information provided is insufficient.
- The product evaluation does not substantiate the claim.
- The unit has been operated above and beyond its capacity or not maintained or serviced properly, resulting in damages incurred to major components.
- If the unit was equipped with a factory installed hour meter which has been disconnected, altered or inoperative for an extended period of time; with the result being that the equipment's operating hours cannot be verified.
- It is apparent that the operator's manuals have not been followed.
- The equipment is not registered.

Without limitation, Walinga's Warranty does not cover:

- Damage or deterioration due to lack of reasonable care or maintenance.
- Damage caused or affected by unapproved modifications to the equipment.
- Damage caused by negligence or misuse of the equipment.
- Damage caused by using the equipment for purposes for which it was not designed or intended.

Walinga's liability under this warranty, whether in contract or tort, is limited to the repair, replacement or adjustment of defective materials and workmanship. In no event will Walinga be responsible for any direct, indirect, loss of time, incidental or consequential expenses including, but not limited to, equipment rental expenses, towing, downtime, inconvenience, or any losses resulting from the inability to use the equipment. Further, Walinga shall not be liable for any damages or inconvenience caused by any delay in the supply or delivery of any equipment or component parts thereof.

The selling Dealer/Sales Person makes no warranty of its own and has no authority to make any representation or promise on behalf of Walinga, or to modify the terms or limitations of the Walinga Warranty in any way.

Punitive, exemplary or multiple damages may not be recovered unless applicable law prohibits their disclaimer. Warranty related claims may not be brought forward as a class representative, a private attorney general, a member of a class of claimants or in any other representative capacity.

The Walinga Warranty and all questions regarding its enforceability and interpretation are governed by the law of the country, state or province in which you purchased your Walinga equipment. The laws of some jurisdictions limit or do not allow the disclaimer of consequential damages. If the laws of such a jurisdiction apply to any claim against Walinga, the limitations and disclaimers contained here shall be to the greatest extent permitted by law.

SERIAL NUMBER LOCATION

Always give your Dealer the Serial Number of your Walinga Ultra-Veyor System when ordering parts or requesting service or other information.



Machine Serial Number



Blower Serial Number



Airlock Serial Number

TABLE OF CONTENTS

1	Introduction	8
	Safety	9
2.1	General Safety.....	10
2.2	Equipment Safety Guidelines	11
2.3	Storage Safety	11
2.4	Safety Training.....	12
2.5	Safety Signs.....	12
2.6	Preparation	13
2.7	Installation Safety	13
2.8	Operating Safety	15
2.9	Maintenance Safety.....	14
2.10	Electical Safety	15
2.11	Lock-Out Tag-Out Safety.....	15
2.12	Employee Sign-Off Form	16
3	Safety Sign Locations	17
4	Operation	21
4.1	To the New Operator or Owner	21
4.2	Machine Components	22
4.3	Machine Break-In	23
4.4	Pre-Operation Checklist	23
4.5	Controls	24
4.5.1	Standard Controls.....	24
4.5.2	Smart-Flo Controls.....	25
4.6	Operating	27
4.7	Storage	31
5	Service and Maintenance	32
5.1	Service.....	32
5.1.1	Fluids and Lubricants.....	32
5.1.2	Greasing	32
5.1.3	Servicing Intervals	33
5.1.4	Service Record	36
5.2	Maintenance	37
5.2.1	Belt Tension and Alignment.....	37
5.2.2	Blower Oil and Breather Cleaning	41
5.3.3	Airlock	43
5.2.4	Gear Box.....	45
6	Trouble Shooting	47
7	Specifications	49
7.1	Mechanical.....	53
7.2	Bolt Torque	54
8	Index	51

1 INTRODUCTION

Congratulations on your choice of a Walinga Ultra-Veyor System to complement your operation. This equipment has been designed and manufactured to meet the needs of the discriminating buyer for the efficient moving of granular or powder products.

Safe, efficient and trouble free operation of your Ultra-Veyor System requires that you and anyone else who will be operating or maintaining the machine, read and understand the Safety, Operation, Maintenance and Trouble shooting information contained within the Operator's Manual.



This manual covers all Ultra-Veyor Systems made by Walinga Inc. Many systems are custom designed for the specific application. However they are all similar and specific differences are explained where appropriate.

Keep this manual handy for frequent reference and to pass on to new operators or owners. Call your Walinga dealer if you need assistance, information or additional copies of the manual. Contact your dealer for a complete listing of parts.

2 SAFETY

SAFETY ALERT SYMBOL

This Safety Alert symbol means
**ATTENTION! BECOME ALERT! YOUR
SAFETY IS INVOLVED!**



The Safety Alert symbol identifies important safety messages on the Walinga® Ultra-Veyor System and in the manual. When you see this symbol, be alert to the possibility of personal injury or death. Follow the instructions in the safety message.

Why is SAFETY important to you?

3 Big Reasons:
Accidents Disable and Kill
Accidents Cost
Accidents Can Be Avoided

SIGNAL WORDS:

Note the use of the signal words **DANGER**, **WARNING** and **CAUTION** with the safety messages. The appropriate signal word for each message has been selected using the following guidelines.

DANGER

- Indicates an imminently hazardous situation that, if not avoided, will result in death or serious injury. This signal word is to be limited to the most extreme situations typically for machine components which, for functional purposes, cannot be guarded.

WARNING

- Indicates a potentially hazardous situation that, if not avoided, could result in death or serious injury, and includes hazards that are exposed when guards are removed. It may also be used to alert against unsafe practices.

CAUTION

- Indicates a potentially hazardous situation that, if not avoided, may result in minor or moderate injury. It may also be used to alert against unsafe practices.

Keep this manual handy for frequent reference and to pass on to new operators or owners. Call your Walinga® dealer if you need assistance, information or additional copies of the manual. Contact your dealer for a complete listing of parts.

SAFETY

YOU are responsible for the **SAFE** operation and maintenance of your Walinga® Ultra-Veyor System. **YOU** must ensure that you and anyone else who is going to operate, maintain or work around the Ultra-Veyor System be familiar with the operating and maintenance procedures and related **SAFETY** information contained in this manual. This manual will take you step-by-step through your working day and alerts you to all good safety practices while operating the Ultra-Veyor System.

Remember, **YOU** are the key to safety. Good safety practices not only protect you but, also the people around you. Make these practices a working part of your safety program. Be certain that **EVERYONE** operating this machine is familiar with the procedures recommended and follows safety precautions. Remember, most accidents can be prevented. Do not risk injury or death by ignoring good safety practices.

- Ultra-Veyor System owners must give operating instructions to operators or employees before allowing them to operate the machine, and at least annually thereafter.
- The most important safety device on this equipment is a SAFE operator. It is the operator's responsibility to read and understand ALL Safety and Operating instructions in the manual and to follow these. Most accidents can be avoided.
- A person who has not read and understood all operating and safety instructions is not qualified to operate this machine. An untrained operator exposes himself and bystanders to possible serious injury or death.
- Do not modify the equipment in any way. Unauthorized modification may impair the function and/or safety and could affect the life of the equipment.
- Think SAFETY! Work SAFELY!

2.1 GENERAL SAFETY

- 1 Read and understand the Operator's Manual and all safety signs before supplying power, operating, maintaining, adjusting or unplugging.
2. Only trained, competent persons shall operate the Ultra-Veyor System. An untrained operator is not qualified to operate this machine.



3. Provide a first-aid kit for use in case of an accident. Store in a highly visible place.



4. Provide a fire extinguisher for use in case of an accident. Store in a highly visible place.



5. Install and properly secure all guards and shields before operating.

6. Wear appropriate protective gear. This list includes but is not limited to:



- A hard hat
- Protective shoes with slip resistant soles
- Protective glasses or goggles
- Heavy gloves
- Wet weather gear
- Hearing protection

- 7 Turn machine OFF, shut down and lockout power supply and wait for all moving parts to stop before servicing, adjusting, maintaining, repairing, cleaning or unplugging. (Safety lockout devices are available through your Walinga® dealer parts department).

8. Know the emergency medical center number for your area.

9. Wear appropriate hearing protection when operating the machine.



10. Ground all lines, hoses and wands to prevent static build-up and electrical discharge/shocks.

11. Review safety related items with all operators annually.

2.2 EQUIPMENT SAFETY GUIDELINES

1. Safety of the operator and bystanders is one of the main concerns in designing and developing a machine. However, every year many accidents occur which could have been avoided by a few seconds of thought and a more careful approach to handling equipment. You, the operator, can avoid many accidents by observing the following precautions in this section. To avoid personal injury or death, study the following precautions and insist those working with you, or for you, follow them.
2. In order to provide a better view, certain photographs or illustrations in this manual may show an assembly with a safety shield removed. However, equipment should never be operated in this condition. Keep all shields in place. If shield removal becomes necessary for repairs, replace the shield prior to use.
3. Replace any safety sign or instruction sign that is not readable or is missing. Location of such safety signs is indicated in this manual.
4. Never use alcoholic beverages or drugs which can hinder alertness or coordination while operating this equipment. Consult your doctor about operating this machine while taking prescription medications.
5. **Under no circumstances should young children be allowed to work with this equipment. Do not allow persons to operate or assemble this unit until they have read this manual and have developed a thorough understanding of the safety precautions and of how it works.** Review the safety instructions with all users annually.
6. This equipment is dangerous to children and persons unfamiliar with its operation. The operator should be a responsible, properly trained and physically able person familiar with farm machinery and trained in this equipment's operations. If the elderly are assisting with farm work, their physical limitations need to be recognized and accommodated.
- 7 Never exceed the limits of a piece of machinery. If its ability to do a job, or to do so safely, is in question - **DON'T TRY IT.**
8. Do not modify the equipment in any way. Unauthorized modification may result in serious injury or death and may impair the function and life of the equipment.
9. In addition to the design and configuration of this implement, including Safety Signs and Safety Equipment, hazard control and accident prevention are dependent upon the awareness, concern, prudence, and proper training of personnel involved in the operation, transport, maintenance, and storage of the machine. Refer also to Safety Messages and operation instruction in each of the appropriate sections of the auxiliary equipment and machine Manuals. Pay close attention to the Safety Signs affixed to the auxiliary equipment and the machine.

2.3 STORAGE SAFETY

1. Store the Ultra-Veyor System on a firm level surface.
2. If required, make sure the unit is firmly blocked up.
3. Make certain that all mechanical locks are safely and positively connected before storing.
4. Store away from areas of human activity.
5. Do not allow children to play on or around the stored Ultra-Veyor System.
6. Lock out power by turning off master control panel or junction box and padlocking the door shut to prevent electrocution or unauthorized start up of the Ultra-Veyor System.

2.4 SAFETY TRAINING

1. Safety is a primary concern in the design and manufacture of our products. Unfortunately, our efforts to provide safe equipment can be wiped out by a single careless act of an operator or bystander.
2. In addition to the design and configuration of equipment, hazard control and accident prevention are dependent upon the awareness, concern, prudence and proper training of personnel involved in the operation, transport, maintenance and storage of this equipment.

3. It has been said, "The best safety feature is an informed, careful operator." We ask you to be that kind of an operator.

It is the operator's responsibility to read and understand ALL Safety and Operating instructions in the manual and to follow these. Accidents can be avoided.



4. **Working with unfamiliar equipment can lead to careless injuries. Read this manual, and the manual for your auxiliary equipment, before assembly or operating, to acquaint yourself with the machines. If this machine is used by any person other than yourself. It is the machine owner's responsibility to make certain that the operator, prior to operating:**

a. Reads and understands the operator's manuals.

b. Is instructed in safe and proper use.

5. Know your controls and how to stop the Ultra-Veyor System and any other auxiliary equipment quickly in an emergency. Read this manual and the one provided with your other equipment.
6. Train all new personnel and review instructions frequently with existing workers. Be certain only a properly trained and physically able person will operate the machinery. A person who has not read and understood all operating and safety instructions is not qualified to operate the machine. An untrained operator exposes himself and bystanders to possible serious injury or death. If the elderly are assisting with work, their physical limitations need to be recognized and accommodated.

2.5 SAFETY SIGNS

1. Keep safety signs clean and legible at all times.
2. Replace safety signs that are missing or have become illegible.
3. Replaced parts that displayed a safety sign should also display the current sign.
4. Safety signs are available from your authorized Distributor or Dealer Parts Department or the factory.

How to Install Safety Signs:

- Be sure that the installation area is clean and dry.
- Be sure temperature is above 50°F (10°C).
- Determine exact position before you remove the backing paper. (See Section 3).
- Remove the smallest portion of the split backing paper.
- Align the sign over the specified area and carefully press the small portion with the exposed sticky backing in place.
- Slowly peel back the remaining paper and carefully smooth the remaining portion of the sign in place.
- Small air pockets can be pierced with a pin and smoothed out using the piece of sign backing paper.

How to Reorder Your Safety Signs:

1. Call your local dealer, or the factory branch nearest you.

FACTORY DISTRIBUTION AND SERVICE CENTRES:

Head Office:

RR#5, Guelph, Ontario, N1H 6J2

PHONE (888) 925-4642

FAX (519) 824-5651

938 Glengarry Cres. Fergus, Ontario Canada N1M 2W7
Tel: (519) 787-8227 Fax: (519) 787-8210

70 3rd Ave. N.E. Box 1790 Carman, Manitoba
Canada R0G 0J0
Tel (204) 745-2951 Fax (204) 745-6309

1190 Electric Ave. Wayland, MI. USA 49348
Tel (800) 466-1197 Fax (616) 877-3474

24 Molloy Street Toowoomba, Queensland Australia 4350
Tel 07.4634.7344 Fax 07.4634.7606

2.6 PREPARATION

1. Never operate the Ultra-Veyor System and auxiliary equipment until you have read and completely understand this manual, the auxiliary equipment Operator's Manual, and each of the Safety Messages found on the safety signs on the and auxiliary equipment.
2. Personal protection equipment including hard hat, safety glasses, safety shoes, and gloves are recommended during assembly, installation, operation, adjustment, maintaining, repairing, removal, or moving the implement. Do not allow long hair, loose fitting clothing or jewelry to be around equipment.



PROLONGED EXPOSURE TO LOUD NOISE MAY CAUSE PERMANENT HEARING LOSS!



3. Motors or equipment attached can often be noisy enough to cause permanent, partial hearing loss. We recommend that you wear hearing protection on a full-time basis if the noise in the Operator's position exceeds 80db. Noise over 85db on a long-term basis can cause severe hearing loss. Noise over 90db adjacent to the Operator over a long-term basis may cause permanent, total hearing loss. **NOTE:** Hearing loss from loud noise (from tractors, chain saws, radios, and other such sources close to the ear) is cumulative over a lifetime without hope of natural recovery.
4. Clear working area of debris, trash or hidden obstacles that might be hooked or snagged, causing injury, damage or tripping.
5. Operate only in daylight or good artificial light.
6. Be sure machine is properly anchored, adjusted and in good operating condition.
7. Ensure that all safety shielding and safety signs are properly installed and in good condition.
8. Before starting, give the machine a "once over" for any loose bolts, worn parts, cracks, leaks, frayed belts and make necessary repairs. Always follow maintenance instructions.

2.7 INSTALLATION SAFETY

1. Disconnect and remove all mechanical locks, anchor chains and any other transport devices that would hinder or prohibit the normal functioning of the Ultra-Veyor System upon start up. Serious damage to the machine and/or personal injury to the operator and bystanders may result from attempting to operate the machine while mechanical locking devices are still attached.
2. Anchor the machine to firm, level ground before operating.
3. Level the frame before using or loading.
4. Have at least one extra person available to assist when elevating, moving or connecting to other equipment.
5. Make certain that sufficient amperage, at the proper voltage and frequency (60Hz) is available before connecting power to the electric model. Have a licensed electrician provide power to the machine. Always follow ANSI/NFPA 70 Standard and all local codes when providing electrical power.
6. If using Ultra-Veyor System as part of material handling system, anchor securely before starting.
7. Vent discharge air from blower to outside.

2.8 OPERATING SAFETY

1. Read and understand the Operator's Manual and all safety signs before operating, maintaining, adjusting or repairing the Ultra-Veyor System.
2. Before servicing, adjusting, repairing or maintaining unit, ensure that unit power source is completely shut down and can not start up.
3. Do not operate when any guards are damaged or removed, Install and secure guards before starting.
4. Keep hands, feet, clothing and hair away from all moving and/or rotating parts.
5. Clear the area of all bystanders, especially small children, before starting.
6. Before supplying electrical power to the machine, be sure you have adequate amperage at the proper phase and voltage to run it. If you do not know or are unsure, consult a licensed electrician.
- 7 Wear appropriate ear protection when operating machine.
8. Do not place intake nozzle near feet when standing on the top of grain.



9. Review safety instructions with all personnel annually.

2.9 MAINTENANCE SAFETY

1. Good maintenance is your responsibility. Poor maintenance is an invitation to trouble. Follow all operating, maintenance and operating instructions in this manual.

2. Support the machine with blocks of safety stands when working beneath it.

3. Follow good shop practices:

- Keep service area clean and dry.
- Be sure electrical outlets and tools are properly grounded.
- Use adequate light for the job at hand.



4. Use only tools, jacks or hoists of sufficient capacity for the job.

5. Before servicing, adjusting, repairing or maintaining unit, ensure that power source is completely shut down and locked-out, tagged-out.

6. Always use personal protection devices such as eye, hand and hearing protectors, when performing any service or maintenance work.

7. A fire extinguisher and first aid kit should be kept readily accessible while performing maintenance on this



equipment.

8. Make sure all guards are in place and properly secured when maintenance work is completed.

9. Keep hands, feet, hair and clothing away from all moving and/or rotating parts.

10. Lock-out, tag-out master panel before performing any maintenance work on machine or opening air-lock access door.

11. Clear the area of bystanders, especially small children, when carrying out any maintenance and/or repairs or making any adjustments.

12. Be sure all lines, hoses and wands are grounded when maintenance work is completed.

2.10 ELECTRICAL SAFETY

1. Have only a qualified licensed electrician supply power to the electric model by following ANSI/ NFPA 70 Wiring Standard. Make certain that the Ultra-Veyor System is properly grounded at the power source.
2. Install safety decals on Master Control panel as per Section 3 - Safety Sign Locations (pg 17)/
3. Make certain that all electrical switches are in the OFF position before plugging the Ultra-Veyor System in.
4. Turn machine OFF, shut down and lock out power supply (safety lockout devices are available through your Walinga® dealer parts department) and wait for all moving parts to stop before servicing, adjusting, maintaining or repairing.
5. Disconnect power before resetting any motor or breaker overload.
6. Replace any damaged electrical plugs, cords, switches and components immediately.
7. Do not work on Ultra-Veyor System electrical system unless the power cord is unplugged or the power supply is locked-out tagged-out.
8. Check continuity of all couplings.



2.8 LOCK-OUT TAG-OUT SAFETY

1. Establish a formal Lock-Out Tag-Out program for your operation.
2. Train all operators and service personnel before allowing them to work around the Ultra-Veyor System.
3. Provide tags at the work site and a sign-up sheet to record tag out details.
4. Do not perform any service or maintenance work unless motor is OFF and the power locked out.

3 SAFETY SIGN LOCATIONS

• Think SAFETY! Work SAFELY!



- SAFETY DECALS - BLOWER

⚠ CAUTION

1. Read and understand the Operator's Manual and all safety signs before using.
2. Turn machine off or lock-out tag-out electrical power and wait for all moving parts to stop before servicing, adjusting, repairing, unplugging or maintaining unit. Ensure that unit power source is completely shut down, and cannot start-up.
3. Do not operate when any guards are damaged or removed. Install and secure guards before starting.
4. Lock out and tag out the master panel before servicing.
5. Keep hands, feet, clothing, and hair away from all moving and/or rotating parts.
6. Clear the area of all bystanders, especially small children, before starting.
7. Ground all lines and hoses to prevent static build-up and electrical discharge/shocks.
8. Maintain electrical continuity between motors to prevent sparks, shocks, or electrical discharge.
9. Wear appropriate ear protection when operating for long periods of time.
10. Review safety items with all personnel annually. 53-90747-6

A

⚠ WARNING

ROTATING PART HAZARD

To prevent serious injury or death from rotating parts:

1. Close and secure guard before operating.
2. Turn machine off or lock-out tag-out electrical power and wait for all moving parts to stop before servicing, adjusting, repairing, unplugging or maintaining unit. Ensure that unit power source is completely shut down and can not start up.
3. Keep hands, feet, hair and clothing away from moving parts.

53-18288-6

B

The types of safety signs and locations on the equipment are shown in the illustration below. Good safety requires that you familiarize yourself with the various safety signs, the type of warning and the area, or particular function related to that area, that requires your SAFETY AWARENESS.

- Think SAFETY! Work SAFELY!



- SAFETY DECALS – AIRLOCK



C



D

REMEMBER - If safety signs have been damaged, removed, become illegible or parts replaced without signs, new signs must be applied. New signs are available from your authorized dealer or factory direct.

The types of safety signs and locations on the equipment are shown in the illustration below. Good safety requires that you familiarize yourself with the various safety signs, the type of warning and the area, or particular function related to that area, that requires your SAFETY AWARENESS.



A



B



C

REMEMBER - If safety signs have been damaged, removed, become illegible or parts replaced without signs, new signs must be applied. New signs are available from your authorized dealer or factory direct.

The types of safety signs and locations on the equipment are shown in the illustration below. Good safety requires that you familiarize yourself with the various safety signs, the type of warning and the area, or particular function related to that area, that requires your SAFETY AWARENESS.

- Think SAFETY! Work SAFELY!



A



B

REMEMBER - If safety signs have been damaged, removed, become illegible or parts replaced without signs, new signs must be applied. New signs are available from your authorized dealer or factory direct.

4 OPERATION



OPERATING SAFETY

Read and understand the Operator's Manual and all safety signs before operating, maintaining, adjusting or repairing the Ultra-Veyor System.

Before servicing, adjusting, repairing or maintaining unit, ensure that unit power source is completely shut down and can not start up.

Establish a Lock-Out Tag-Out program for the worksite.

Do not operate when any guards are damaged or removed, Install and secure guards before starting.

Keep hands, feet, clothing and hair away from all moving and/or rotating parts.

Lock-out tag-out master panel before opening airlock door.

Clear the area of all bystanders, especially small children, before starting.

Before supplying electrical power to the machine, be sure you have adequate amperage at the proper phase and voltage to run it. If you do not know or are unsure, consult a licensed electrician.

Ground all lines and hoses to prevent static build-up and electrical discharge.

Maintain electrical continuity between material intake and airlock/blower to prevent sparks, shocks or electrical discharges.

Wear appropriate ear protection when operating machine.

Review safety instructions annually.

4.1 TO THE NEW OPERATOR OR OWNER

The Walinga Ultra-Veyor System is specifically designed to convey grain, powder or other granular material and move it in a stream of pressurized air to cyclones or deadheads. Be familiar with all operating and safety procedures before starting.

It is the responsibility of the owner and operator to read this manual and to train all other operators before they start working with the machine. Follow all safety instructions exactly. Safety is everyone's business. By following recommended procedures, a safe working environment is provided for the operator, bystanders and the area around the worksite. Untrained operators are not qualified to operate the machine.

Many features incorporated into this machine are the result of suggestions made by customers like you. Read this manual carefully to learn how to operate the machine safely and how to set it to provide maximum efficiency. By following the operating instructions in conjunction with a good maintenance program, your Ultra-Veyor System will provide many years of trouble-free service.

4.2 MACHINE COMPONENTS

The material drops into the turning airlock. The airlock will bring pockets of material from atmospheric pressure into a pressure line without losing air. Pressure line air is supplied by a positive displacement blower.

- A Blower Electric Motor**
- B Belt Drive**
- C Blower**
- D Air Lock**

- E Gearbox (twopiece unit only)**
- F Airlock Electric Motor(two piece unit only)**
- G Product Inlet**
- H Airlock Inlet**



BLOWER PACKAGE



AIRLOCK PACKAGE



ONE PIECE UNIT

4.3 BREAK-IN

Although there are no operational restrictions on the Ultra-Veyor System when used for the first time, it is recommended that the following mechanical items be checked:

A. After operating for 1/2 hour:

1. Retorque all fasteners and hardware.
2. Turn blower and airlock by hand. Be sure that they turn freely.
3. Check that no hoses are pinched, rubbing or being crimped. Re-align as required.
4. Check oil level in reservoirs. Add as required.
5. Lubricate all grease fittings.

B. After operating for 5 hours and 10 hours:

1. Retorque all bolts, fasteners and hardware.
2. Check hose routing.
3. Check that blower and airlock turn freely.
4. Check oil level in reservoirs.
5. Then go to the normal servicing and maintenance schedule as defined in the Maintenance Section.

4.4 PRE-OPERATION CHECKLIST

Efficient and safe operation of the Walinga Ultra-Veyor System requires that each operator reads and understands the operating procedures and all related safety precautions outlined in this section. A pre-operation checklist is provided for the operator. It is important for both the personal safety and maintaining the good mechanical condition of the Ultra-Veyor that this checklist is followed.

Before operating the Ultra-Veyor and each time thereafter, the following areas should be checked off:

1. Lubricate the machine per the schedule outlined in Section 5 Service and Maintenance.
2. Check the oil level in the blower reservoirs.
3. Inspect all air lines, hoses, fittings and couplers for tightness.
4. Check that the blower and airlock turn freely.
5. Check for and remove entangled material.
6. Close and secure all guards.

4.5 CONTROLS

NOTE:

Walinga supplies a standard Ultra-Veyor for Farm use, as well as a unit for Commercial applications equipped with a Smart-Flo Control Panel. Please ensure you or anyone else who will be operating or maintaining the machine understand the difference as outlined below as per Section 4.5.1 (Standard) and Section 4.5.2 (Commercial) with Smart-Flo panel.

4.5.1(Standard Controls)

All controls for the machine are provided by the customer. Each installation should have provisions to lock out tag out the master panel for maintenance. Review your installation carefully to familiarize yourself with the function and movement of each control before starting.

1. Electrical Switches:

It is recommended that the electrical controls be set up to include a master panel with the capabilities of lock out tag out for service/ maintenance and an on/off switch.

Review your installation details before starting.

Fig.4.2 CONTROLS (TYPICAL)



Master Panel



Power Disconnect

4.5 CONTROLS (Cont'd)

4.5.2 SMART FLO CONTROLS: (For units equipped with a Smart-Flo Control Panel only)

Each customer is responsible to provide the appropriate control panel and power supply to the machine. It is recommended that the customer have a licensed electrician provide the power per ANSI/NFPA70 Standard and all applicable local codes when providing power to the motor.

The Smart Flo System can be wired into a large control room away from the machine.

Be familiar with the specific control box system before starting.

1. SMART FLO CONTROL PANEL:

a. Start:

This green two-position push-button switch is used to turn power ON to the VFD. Depress the switch to turn power ON. When the button is depressed, the blower running light will illuminate, then after a 30 second delay, the A/L running light will illuminate.

b. Stop

This red two-position push-button switch is used to turn power OFF to the VFD. Depress the switch to turn power OFF. When the button is depressed, the A/L running light will turn off, then after a 30 second delay, the blower running light will turn off.

c. Kill Button:

The kill button immediately stops the blower and the airlock, regardless of external commands.

d. Airlock Running:

This light is illuminated when the airlock is running, and turns off when the airlock stops.

e. Blower Running:

This light is illuminated when the blower is running, and turns off when the blower stops.

IMPORTANT !

The blower is designed to run for approximately 30 seconds before the airlock turns on, and will continue for 30 seconds after the airlock shuts down. This insures the lines are empty before turning off all air flow.

f. Auto/Manual Selector:

This 2 position selector switch is used to select the running mode of the Smart Flo panel. Auto allows the system to adjust the blower speed based on product volume, condition, and conveying distance. Manual will allow a preset speed to be set, causing the smart flow system to run at exactly that speed. The system should always be set in auto unless the system is running poorly.

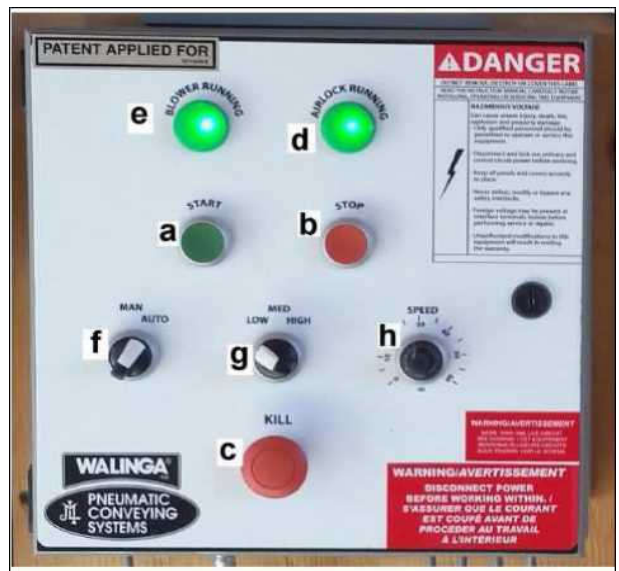

Fig. 4.3 SMART FLO MASTER CONTROL PANEL.

g. Speed Selector:

This 3 position selector switch is used to select different blower speeds. Low, medium, and high set the idling speed of the blower. Generally, the low speed position will work at all times, however if plugging occurs select medium or high. This selector only effects the blower speed when the system is in auto.

h. Speed Dial.

This variable position dial allows the blower speed to be set when the Smart Flo system is in manual.

2. RESET PROCEDURE:

If the Smart Flo panel is receiving an external run signal (starts and stops from a drier), and the kill button is depressed, a reset procedure needs to be followed.

Release the kill button

Press the start button

Press the stop button

The external signal will now control the blower and airlock again.

3. POWER DISCONNECTS:

The system is designed with switches close to the machine that allow the operator to disconnect the power to the respective motors as required. Turn the switch to its vertical configuration to provide power to the motor, and horizontal to disconnect power.



Fig.4.4 POWER DISCONNECT

4. **Starting Machine:**
 - a. Check that the master panel is not locked out.
If it is, identify cause and retrieve the tag. Turn master panel on.
 - b. Turn machine on by depressing the green start button.
5. **Stopping Machine:**

Turn the machine off using the red stop button. Depress the stop button to shut down both the blower and the airlock.

OPERATING SAFETY ULTRA-VEYOR WITH SMART-FLO

- Close and secure all guards, shields and access doors before starting.
- Starting the Ultra-Veyor:
 - Turn power ON
 - Blower runs 30 seconds before airlock starts
 - Proceed with work
- Stopping the Ultra-Veyor:
 - Turn power OFF
 - Airlock stops
 - Blower runs for 30 seconds after airlock stops
 - Blower stops

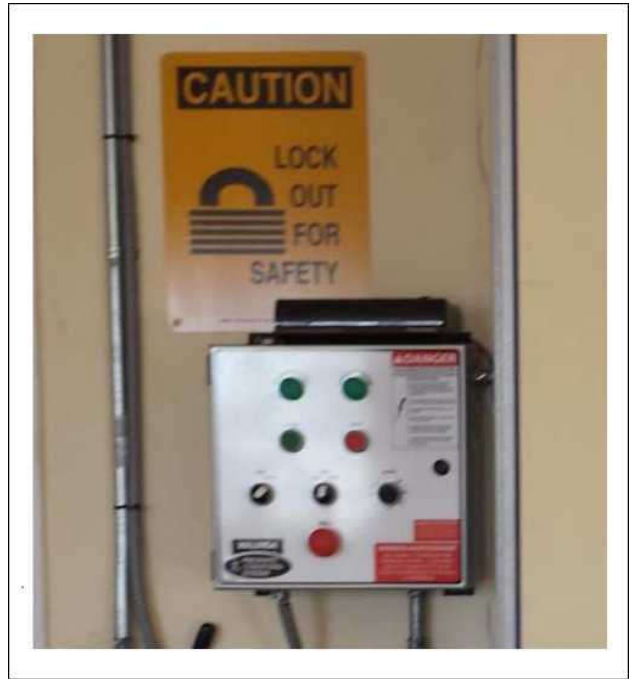

Fig. 4.5 SMART FLO MASTER CONTROL PANEL

4.6 OPERATING



OPERATING SAFETY

Read and understand the Operator's Manual and all safety signs before operating, maintaining, adjusting or repairing the Ultra-Veyor System.

Before servicing, adjusting, repairing or maintaining unit, ensure that unit power source is completely shut down and can not start up.

Establish a Lock-Out Tag-Out program for the worksite.

Do not operate when any guards are damaged or removed, Install and secure guards before starting.

Keep hands, feet, clothing and hair away from all moving and/or rotating parts.

Lock-out tag-out master panel before opening airlock door.

Clear the area of all bystanders, especially small children, before starting.

Before supplying electrical power to the machine, be sure you have adequate amperage at the proper phase and voltage to run it. If you do not know or are unsure, consult a licensed electrician. Ground all lines and hoses to prevent static build-up and electrical discharge.

Maintain electrical continuity between material intake and airlock/blower to prevent sparks, shocks or electrical discharges.

Wear appropriate ear protection when operating machine.

Review safety instructions annually.



When operating the Ultra-Veyor System, follow this procedure:

1. Clear the area of bystanders, especially small children, before starting.
2. Review and follow the Pre-Operation Checklist (See Section 4.4).
3. Before starting the system in an automatic operation consider the following:
 - i Start system manually to ensure blower and airlock turn freely.
 - ii Check all product lines, switch hoses to each line.
 - iii Manually run the blower without product. Check pressure gauge to ensure each line is free of obstructions.

4. **Starting Machine:**
 - a. Check that the master panel is not locked out. If it is, identify cause and retrieve the tag. Turn master panel on.
 - b. Turn machine on at the On/Off switch.

5. **Stopping Machine:**

Turn the machine off using the On/Off switch. This will shut down both the blower and the airlock.



Master



On/Off

Fig. 5 SWITCHES (TYPICAL)

6. **Airlock:**

The system is designed with an airlock to remove material from the air flow. It is located under the grain dryer. The collected material drops into an airlock compartment as it turns. As the rotor turns and a compartment moves from its up position to its down position, the material in the rotor compartment will fall out.



Fig. 10 AIRLOCK

7. **Airlock Unplugging:**

If a large piece of debris is drawn into the intake, it can get into the airlock, stall it and have to be removed. To unplug, lock out tag out master panel and remove obstruction through the

Rotate airlock by hand after obstruction is removed to be sure airlock turns freely and has not been damaged. Repair airlock if damaged before resuming work.

8. **Lock Out Tag Out Procedure:**

It is recommended that the customer institute a formal lock out tag out procedure for their workplace. In simple terms, this policy would require every person that will be servicing, adjusting, maintaining or unplugging the system to lock out the master panel and place a tag on it before working on the unit. Only the person with the tag can unlock the master switch to allow it to be turned on. This prevents unauthorized people from starting up the system and maintains control by the serviceman working on the system.

9. **Operating Hints:**

- a. Lock out tag out master panel before performing any service or maintenance work on machine or unplugging airlock.
- b. Maintain electrical continuity through all components to prevent sparks, shock or electrical discharges. Do not use plastic components.
- c. Remove obstructions from airlock through after the master panel is locked out tagged out.



Fig. 12 OPERATING

4.7 STORAGE

STORAGE SAFETY

1. Store unit in an area away from human activity.
2. Do not permit children to play on or around the stored machine.
3. Lock out tag out master panel to prevent unexpected start-up.

If the machine will not be used for a period of time, the machine should be thoroughly inspected and prepared for storage. Repair or replace any worn or damaged components to prevent any unnecessary down time when it will be used again.

Follow this procedure:

1. Wash the entire machine thoroughly using a water hose or pressure washer to remove all dirt, mud or residue.
2. Lubricate all grease points. Make sure all grease cavities have been filled with grease prior to storage.
3. Inspect all air hoses, fittings and lines. Tighten any loose fittings. Replace any hose that is badly cut, nicked or abraded or is separating from the crimped end of the fitting.
4. Check the oil level in the blower reservoirs. Bring to the recommended level.
5. Spray oil internally in airlock.
6. Touch up all nicks and scratches to prevent rusting.

5 SERVICE AND MAINTENANCE

MAINTENANCE SAFETY

1. Follow ALL the operating, maintenance and safety information in the manual.
2. Follow good shop practices:
 - Keep service area clean and dry.
 - Be sure electrical outlets and tools are properly grounded.
 - Use adequate light for the job at hand.
- 3 Use only tools, jacks and hoists of sufficient capacity for the job.
4. Before servicing, adjusting, repairing or maintaining unit, ensure that unit power source is completely shut down, and can not start-up.
5. Lock out tag out master panel before servicing airlock.
6. Lock out tag out master panel before performing any maintenance or service work on machine.
7. Keep hands, feet, hair and clothing away from all moving and/or rotating parts.
8. Clear the area of bystanders, especially small children, when carrying out any maintenance and repairs or making any adjustments.
9. Be sure that all lines and hoses are grounded when maintenance work is completed.
10. Make sure all guards are in place and properly secured when maintenance work is completed.

5.1 SERVICE

5.1.1 FLUIDS AND LUBRICANTS

1. **Grease:**
Use an SAE multi-purpose high temperature grease with extreme pressure (EP) characteristics. Also acceptable is an SAE multipurpose lithium based grease.
2. **Blower Oil:**
Use Walinga Super Duty Blower oil (Walinga Part# 98-13813-5) or equivalent.

SIZE	510	614
Front	1.0 liter (1.1qt)	1.4 liter (1.5 qt)
Rear	2.0 Liters (2.1 qts)	2.5 liters 2.6qts)

3. **Storing Lubricants:**
Your unit can operate at top efficiency only if clean lubricants are used. Use clean containers to handle all lubricants. Store them in an area protected from dust, moisture and other contaminants.

5.1.2 GREASING

Refer to Section 5.1.1 for recommended grease. Use the Service Record checklist provided to keep a record of all scheduled servicing.

1. Use a hand-held grease gun for all greasing.
 1. Wipe grease fitting with a clean cloth before greasing, to avoid injecting dirt and grit.
 2. Replace and repair broken fittings immediately.
 3. If fittings will not take grease, remove and clean thoroughly. Also clean lubricant passageway. Replace fitting if necessary.

5.13 SERVICING INTERVALS

8 Hours or Daily

1. Check the tension and alignment of the input drive belts. See Maintenance Section.



Fig. 5.1 DRIVE BELTS (ALIGNMENT)

2. Check the oil level in the blower reservoirs (2 locations)

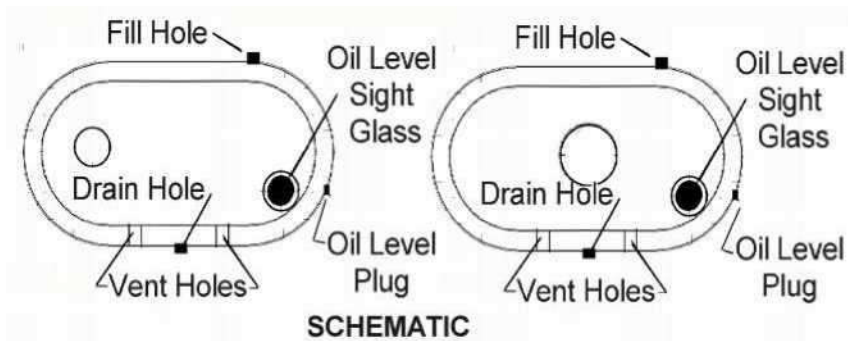

Front

Rear

Fig. 5.2 RESERVOIRS

40 Hours

1. Check airlock gearbox



Fig. 5.3 Gearbox

2. Lubricate the blower outboard bearing (1 location) if applicable.

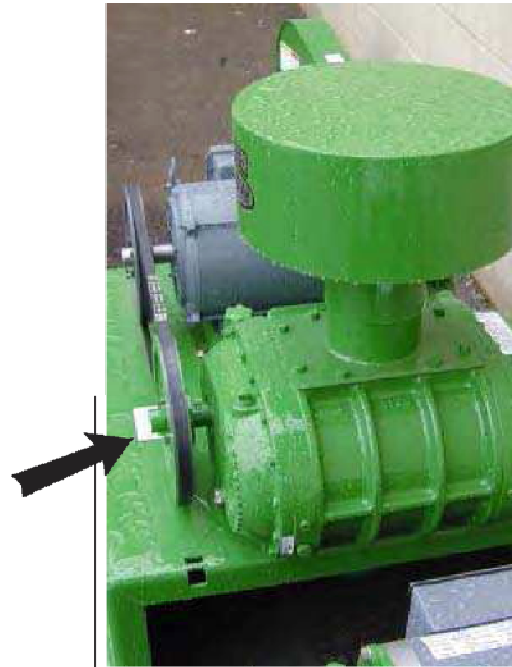

Fig. 5.4 OUTBOARD BEARING (if applicable)

100 Hours or Annually

1. Change the oil in the blower reservoirs (2 reservoirs), and clean head plate vent holes.

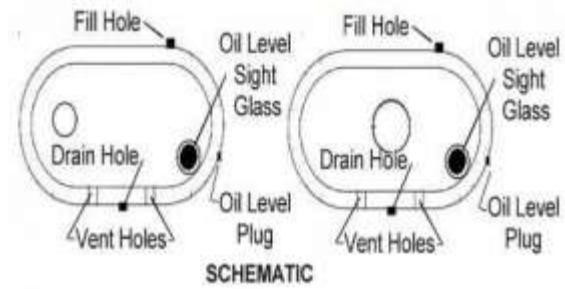

Fig. 5.5 BLOWER RESERVOIRS

2. Check the function of the pressure relief valve.



Fig. 5.6 PRESSURE RELIEF VALVE

5.2 MAINTENANCE

By following a careful service and maintenance program for your machine, you will enjoy many years of trouble-free service.



Fig. 5.7 BELT COVERS

5.2.1 BELT TENSION AND ALIGNMENT

Rotational power from the electric motor is transmitted to the blower through the belt drive. To obtain efficient transmission of power and good belt life, the belts must be properly tensioned and the pulleys aligned.

Belts that are too tight will stretch and wear quickly or overload the bearings on the motor or blower. Belts that are too loose will not transmit the required power and will slip, overheat and wear quickly. Pulleys that are not aligned will result in rapid belt wear.

Follow this procedure when checking and adjusting belt tension and pulley alignment.

1. Clear the area of bystanders, especially small children.
2. Turn machine off, lock out tag out master control panel and wait for all moving parts to stop before starting maintenance work.
3. Unbolt and remove the belt cover. Lay to the side.

4. Use the appropriate weight to determine the belt deflection in a static condition (Table 1)



5. **Adjusting Tension:**

- a. Loosen the jam nuts on the motor base and position adjusting bolts. Loosen base bolts slightly.

- b. Turn the adjusting bolt to set the tension. Turn both bolts the same amount to maintain pulley alignment.

- c. Check the tension again. Over tightening will cause belt stretching and overload the bearing. Belts that are too loose will slip, tear and wear rapidly. Check alignment, see next section.

- d. Tighten base position bolts.

- e. Tighten jam nuts.

- f. Install and secure belt covers.

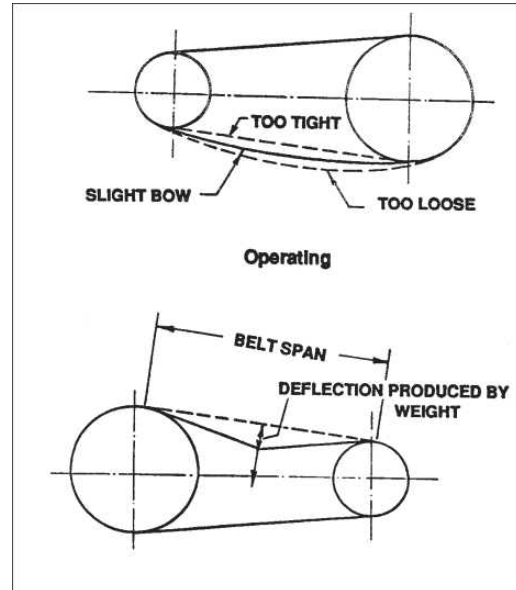

Fig.5.8 BELT DEFLECTION



Fig. 5.9 ADJUSTING BOLTS

6. Pulley Alignment:

- a. Lay a straight-edge across the face of the pulley.
- b. If the gap between the pulley and the straight-edge exceeds 1/16 inch (1.5 mm), the pulleys must be realigned.
- c. Review the types of alignment before starting.



Fig. 5.10 PULLEYS

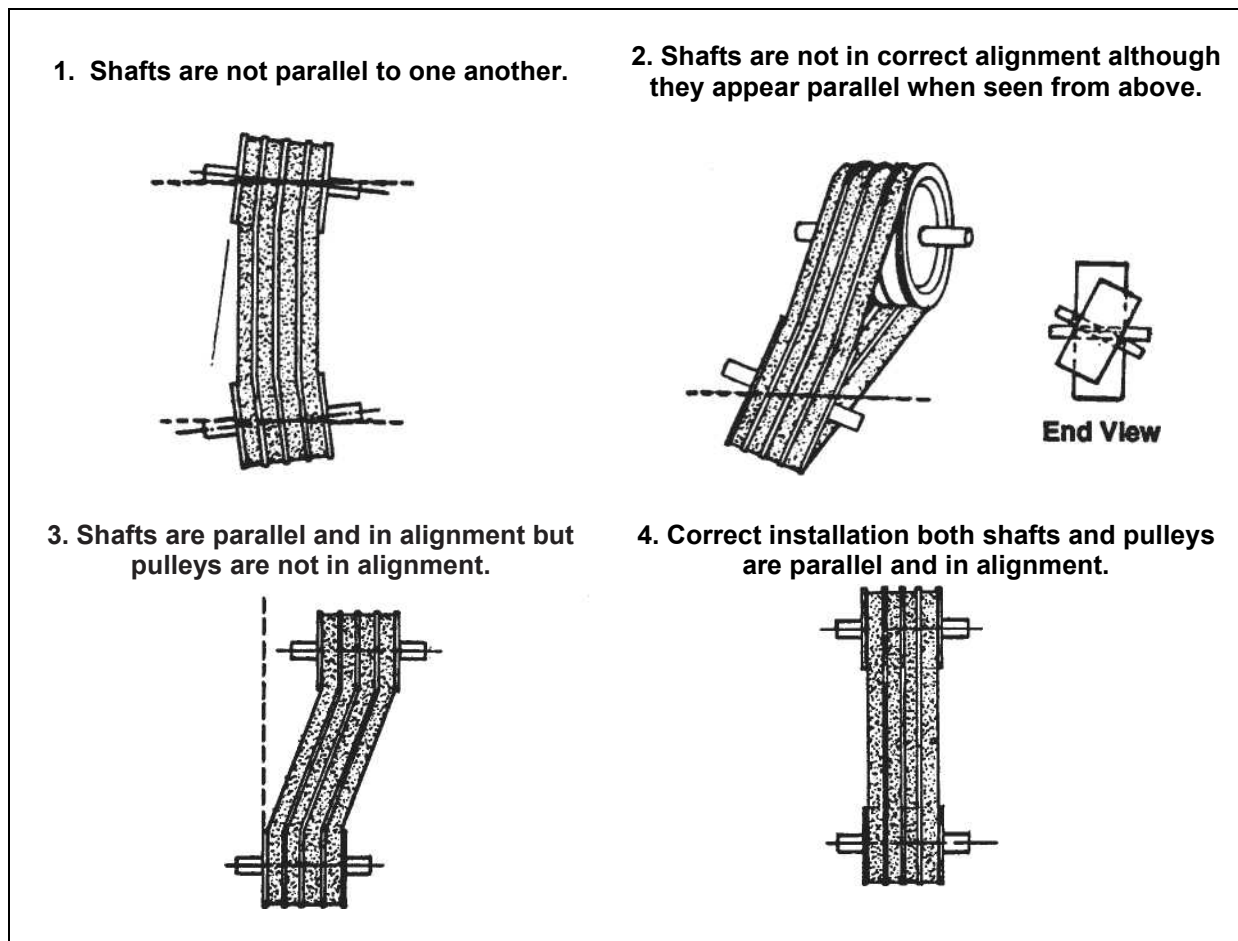

Fig. 5.11 MISALIGNMENT

- d. Use the position adjusting bolts on motor base to align the input pulley. Tighten motor base anchor bolts and jam nuts when alignment has been completed.
 - e. Set the belt tension.
 - f. Install the belt cover and secure with bolts.
7. Be sure all guards are installed and secure before resuming work.

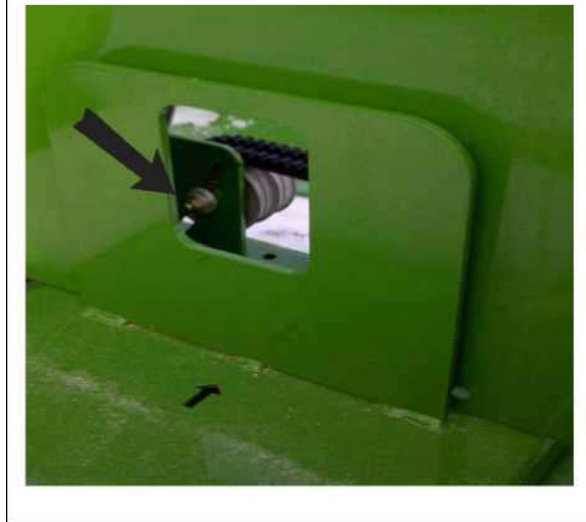

Fig. 5.12 ADJUSTING BOLTS

5.2.2 BLOWER OIL CHANGING AND BREATHER CLEANING

The gears that drive and time the blower lobes run in an oil bath for lubrication. Maintaining the correct level in the reservoirs and changing every 100 hours will insure proper lubrication.

When maintaining the blower, follow this procedure:

1. Clear the area of bystanders, especially small children.
2. Turn machine off, lock out tag out master control panel and wait for all moving parts to stop before starting maintenance work.
3. Unlatch and remove the belt drive covers.
4. Checking Oil Level:
 - a. Remove the level plug in each reservoir or check the sight glass.

IMPORTANT

Check the level only when the oil is cold and the machine is level.

- b. Oil in the reservoir should just fill the threads of the level plug hole.
- c. Add oil if low or allow the reservoir to drain if overfilled.

IMPORTANT

It is necessary to maintain the recommended oil level in the reservoir. A low level causes heating from lack of lubrication and rapid gear and bearing wear. Too much oil causes heating from oil churning and can cause seal and breather leaks.

- d. Install and tighten the level plug.
- e. Install and secure the belt covers.

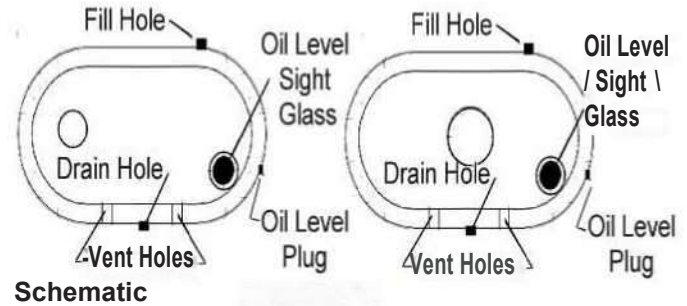

Front



Rear

Fig. 5.13 BLOWER



5. Changing Oil:

- a. Place a collection pan or pail under each drain plug.
- b. Remove each drain plug.
- c. Flush each case and allow several minutes to drain.
- d. Dispose of the oil in an approved manner.

Do not contaminate the worksite with used oil.

- e. Install and tighten the drain plugs.
- f. Remove fill and level plugs.
- g. Add Walinga Blower oil or equivalent to each reservoir until the oil is just starting to come out of the level plug hole.
- h. Install and tighten the fill and level plugs.
- i. Install and secure the belt drive covers.

IMPORTANT

Condensation forms and collects inside the reservoirs during machine operation. Changing oil removes this water and prevents it from damaging the gears and bearings.

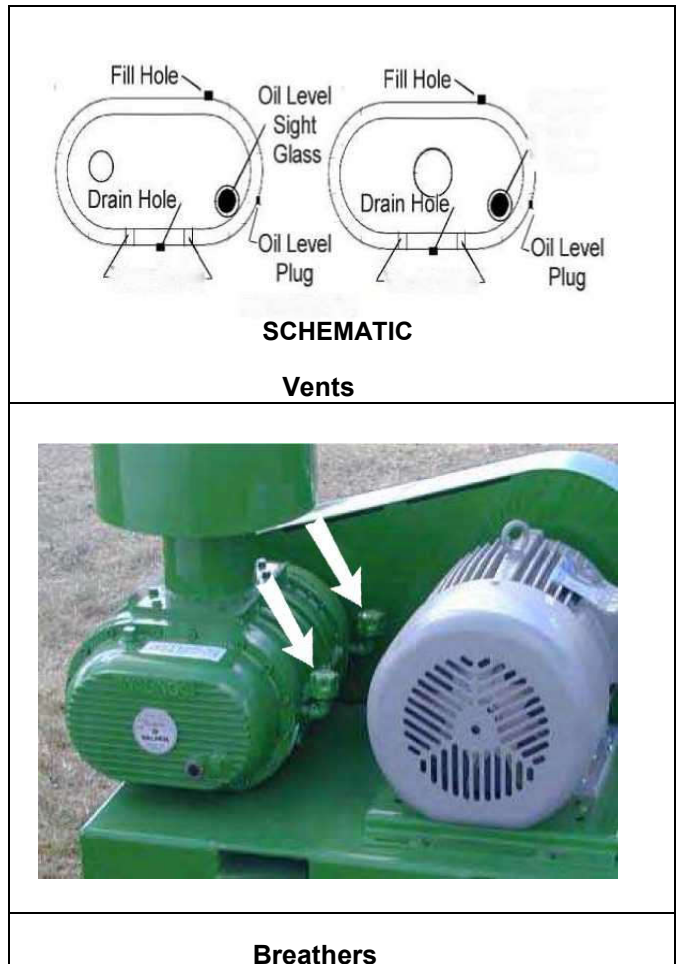

Fig. 5.14 BLOWER

6. Cleaning Breathers:

- a. Remove breathers and blow out with an air hose.
- b. If dirt has caked up in the breather, soak in good solvent and then blow out. It may be necessary to use a probe to loosen the dirt.
- c. Install and tighten the breather.
- d. Install and secure the belt drive covers.
- e. Clean vents in end plates located under the blower on either side of the drain plug.

5.2.3 AIRLOCK

The airlock acts as a seal between the vacuum and atmosphere sides of the machine and is located at the bottom of the collector cyclone tank.

As the airlock rotor turns, a pocket is filled with material when it points upward. As the pocket rotates, it is moved to the bottom where the material drops out of the pocket into the discharge pipe.

Efficient operation of the airlock requires a close fit between the tips of the rotor and the case to maintain a seal between vacuum and atmosphere sides.

When checking or maintaining the airlock, follow this procedure:

1. Clear the area of bystanders, especially small children.
2. Turn machine off, lock out tag out master control panel and wait for all moving parts to stop before starting maintenance work.
3. **Checking Tip Clearance:**
 - a. Use a feeler gauge to check the clearance between the tip and the case. Inspect each tip over its entire width.
 - b. The clearance of the tips must be maintained at 0.005 to 0.007 inches at all times. Adjust or replace tips as required to insure system sealing.
 - c. Replace any tips that are bent, chipped or broken.

NOTE

Blades are reversible if not excessively damaged.



Fig. 5.15



Fig. 5.16 AIRLOCK

4. Wiper Blade:

A wiper blade is located at the top of the airlock to clean the tips as the airlock turns.

To check the wiper blade, follow this procedure:

- a. Reach into the top of the airlock and feel the condition of the wiper blade.
- b. Replace it if it is damaged in any way.

5. Blade Replacement:

- a. Lock out tag out master panel.
- b. Lift the airlock inlet assembly off the airlock.
- c. Remove the anchor bolts.
- d. Remove the tips from the rotor and the wiper blade from the housing.
- e. File the ends of each replacement blade so there is approximately 0.006 inches of clearance between the ends and the housing.
- f. Mount the blades to their respective vane and tighten bolts finger tight.
- g. Rotate airlock rotor slightly to set the clearance between the blade and the case. Be sure to set it at 0.004 inches of clearance. Use a feeler gauge.
- h. Tighten the center bolt first. Then the others.
- i. Rotate the airlock and listen if it touches the housing anywhere. A slight touch is alright.
- j. Repeat mounting procedure with the other blades.
- k. Turn the rotor after each blade is installed to be sure it does not contact the case.
- l. Mount the new wiper blade. Be sure the wiper contacts each tip slightly as the airlock turns.
- m. Clean thoroughly.



Fig. 5.17 Airlock



5.2.4 GEAR BOX

Rotational power to drive the airlock is provided by an electric motor through a gearbox.

The Gear Box is only used on the Walinga Ultra-Veyor two piece systems.
One piece Ultra-Veyor Systems use one electric motor to operate the blower and airlock.

Two power sources are needed for the two piece system, whereas the one piece system only uses one power source.



Fig: 5.18 GEARBOX

6 TROUBLE SHOOTING

The Walinga Ultra-Veyor System is a high capacity air pump. It is a simple and reliable system that requires minimum maintenance.

In the following section, we have listed many of the problems, causes and solutions to the problems that you may encounter.

If you encounter a problem that is difficult to solve, even after having read through this trouble shooting section, please call your Walinga dealer. Before you call, please have this Operator's Manual and the serial number from your Ultra-Veyor ready.

PROBLEM	CAUSE	SOLUTION
Slow discharge of material	Air leaks.	Tighten all pressure connections. Be sure seals are in good condition. Check hoses for leaks Check pressure relief valve. Replace if defective. Clear obstruction.
	Defective blower.	Check clearance between lobes and case. Excessive clearance will decrease air flow. Consult your dealer.
Pulsation.	Defective airlock.	Check that tip clearance is 0.004 inches. Adjust or replace tips as required.
	Not enough air flow.	Slow the amount of product falling into the airlock.
Blower overheating.	Too many bends.	Straighten out discharge hoses.
	Not enough air flow.	Slow the amount of product falling into the airlock.
	Low oil level.	Add oil as required.

PROBLEM	CAUSE	SOLUTION
Noisy airlock.	Tips hitting case.	Readjust tips where applicable.
Airlock stalls.	Airlock jam.	Remove obstruction from airlock by opening inspection door or discharge line. Lock out tag out master panel.
 <p>WARNING Lock-out, tag-out master panel before inspecting or maintaining airlock.</p>		
	Blades too tight.	Loosen bolts. Refer to airlock maintenance.
	Faulty airlock motor or gearbox.	Replace motor or gearbox as required.
Air loss through airlock.	Tip clearance too large.	Adjust tips to decrease clearance to 0.006 inches
Breaking rotor blades.	Blades too tight.	Loosen bolts. Refer to airlock maintenance.
Low air volume.	Slow speed.	Check for slipping belts. Adjust belt tension as required.
	Piping blocked.	Check inlet and outlet piping. Remove obstruction.
		Check relief valve. Clean, repair or replace as required.
	Worn components.	Check clearance and replace defective components. Refer to Blower Manual.
Overheating.	Inadequate lubrication.	Check oil level in reservoirs. Add as required.
	Excessive lubrication.	Check oil level. Correct as required.
	Coupling misalignment.	Check and realign.

PROBLEM**CAUSE****SOLUTION**

Motor overloading.

Impellers rubbing.

Consult your nearest dealer.

Pipes blocked.

Check outlet piping.
Remove obstruction.

Loss in drive speed.

Belts slipping.

Tighten belts as required.

Localized belt wear.

Check cross-section dimension.

- a. If narrow, pulley spinning.
- b. If swollen, belt failing internally.

Unequal stretch on belts.

Defective belts. Replace with matched set.

Belts overloaded.

Belts failed or worn out. Replace belts with matched set.

Belt separation.

Belts too tight. Replace belts and set correctly.

Envelope seams opening.

Check for oil or rubber solvent.
Eliminate contamination and replace belts.

Abnormal envelope wear.

Check for worn sheave, misalignment or slip. Replace defective parts, adjust properly and replace belt.

Belt softening or swelling.

Eliminate oil or rubber solvent.
Replace belt.

Belt hardening or cracking.

Eliminate heat or chemical contamination. Replace belt.

7 SPECIFICATIONS

7.1 MECHANICAL

Model	Motor hp/phase	Blower model/cfm	Airlock model	Line Size	Capacity*	
					bushels/hr	tonnes/hr
4510UV10-1PC	10 / 1	510 / 450	1210	4" (100mm)	524	13.3
4510UV15-1PC	15 / 1	510 / 500	1210	4" (100mm)	689	17.5
4510UV20-1PC	20 / 3	510 / 650	1210	4" (100mm)	827	21
4510UV10	10 / 1	510 / 500	1314	4" (100mm)	524	13.3
4510UV20	20 / 3	510 / 650	1314	4" (100mm)	827	21
5510UV30	30 / 3	510 / 800	1314	5" (125mm)	1153	29.3
5614UV40	40 / 3	614 / 900	1314	5" (125mm)	1366	34.7
5614UV50	50 / 3	614 / 1050	1314	5" (125mm)	1575	40
6614UV60	60 / 3	614 / 1200	1618	6" (150mm)	1890	48
6614UV75	75 / 3	614 / 1400	1618	6" (150mm)	2205	56
7614UV100	100 / 3	614 / 2000	2018	7" (178mm)	2953	75

*Capacities based on moving dry corn approximately 100' (30.4m) Barometric pressure, humidity, and condition of product will affect capacity. Due to continuous product development, specifications are subject to change.

7.2 BOLT TORQUE

CHECKING BOLT TORQUE

The tables shown below give correct torque values for various bolts and capscrews. Tighten all bolts to the torques specified in chart unless otherwise noted. Check tightness of bolts periodically, using bolt torque chart as a guide. Replace hardware with the same strength bolt.

ENGLISH TORQUE SPECIFICATIONS

Bolt Diameter "A"	Bolt Torque*					
	SAE 2 (N.m) (lb-ft)		SAE 5 (N.m) (lb-ft)		SAE 8 (N.m) (lb-ft)	
1/4"	8	6	12	9	17	12
5/16"	13	10	25	19	36	27
3/8"	27	20	45	33	63	45
7/16"	41	30	72	53	100	75
1/2"	61	45	110	80	155	115
9/16"	95	60	155	115	220	165
5/8"	128	95	215	160	305	220
3/4"	225	165	390	290	540	400
7/8"	230	170	570	420	880	650
1"	345	225	850	630	1320	970

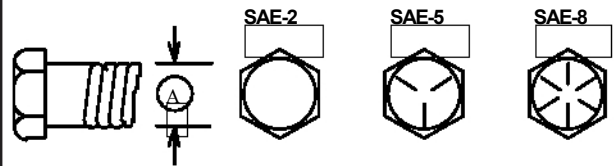

METRIC TORQUE SPECIFICATIONS

Bolt Diameter "A"	Bolt Torque*			
	8.8 (N.m) (lb-ft)		10.9 (N.m) (lb-ft)	
M3	.5	.4	1.8	1.3
M4	3	2.2	4.5	3.3
M5	6	4	9	7
M6	10	7	15	11
M8	25	18	35	26
M10	50	37	70	52
M12	90	66	125	92
M14	140	103	200	148
M16	225	166	310	229
M20	435	321	610	450
M24	750	553	1050	774
M30	1495	1103	2100	1550
M36	2600	1917	3675	2710

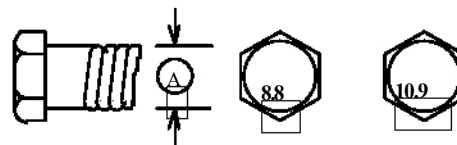

Torque figures indicated above are valid for non-greased or non-oiled threads and heads unless otherwise specified. Therefore, do not grease or oil bolts or capscrews unless otherwise specified in this manual. When using locking elements, increase torque values by 5%.

* Torque value for bolts and capscrews are identified by their head markings.

8 INDEX

Introduction	8
O	
Operation	21
Controls	24
Machine Components	22
Operating	27
Pre-Operation Checklist	23
Storage	31
To the New Operator or Owner	21

S

PAGE

Safety	9
Electro-Static Safety	15
General Safety	10
Installation Safety	13
Maintenance Safety	14
Operating Safety	14
Safety Signs	12
Sign-Off Form	16
Storage Safety	11
Safety Sign Locations	17
Service and Maintenance	32
Maintenance	37
Airlock	43
Belt Tension and Alignment	37
Blower Oil Changing and Breather Cleaning	41
Service	32
Fluids and Lubricants	32
Greasing	32
Service Record	36
Servicing Intervals	33
Specifications	49
Bolt Torque	54
Mechanical	53

T

Trouble Shooting	47
------------------------	----



Ultra-Veyor Operator's Manual

WALINGA[®]
INC.

CORPORATE HEAD OFFICE:

5656 Highway 6N
RR#5, Guelph, Ontario Canada N1H 6J2
Tel: (888) 925-4642 Fax: (519) 824-5651

FACTORY DISTRIBUTION AND SERVICE CENTRES:

938 Glengarry Cres. Fergus, Ontario Canada N1M 2W7
Tel: (519) 787-8227 Fax: (519) 787-8210

1190 Electric Ave. Wayland, MI.USA 49348
Tel (800) 466-1197 Fax (616) 877-3474

70 3rd Ave. N.E. Box 1790 Carman, Manitoba Canada R0G 0J0
Tel (204) 745-2951 Fax (204) 745-6309

24 Molloy Street Toowoomba, Queensland Australia 4350
Tel 07.4634.7344 Fax 07.4634.7606

PRINTED IN CANADA

Rev2: Feb., 2016

Ultra-Veyor OM Part #34-60660-6 v2.34 01172020