

WITH **Smart-Flo**



OPERATOR'S MANUAL

Smart-Flo 2.0

English

WALINGA®
TOUGH TO BEAT IN THE LONG RUN

00-146430-0 D
2025-02-13

TO OUR VALUED CUSTOMERS:

The Walinga network of distribution centers and authorized dealers are dedicated to providing worldwide coverage of original parts and accessories for Walinga Pneumatic Conveying Systems. Our parts reflect Walinga's continued commitment to provide our customers with the highest quality parts and service.

For your convenience, should you require any information related to technical support, warranty, service, parts, or sales, please contact one of the following Walinga personnel:

TECHNICAL SUPPORT

1-833-233-8227 pcs.techsupport@walinga.com

WALINGA WARRANTY COORDINATORS

Canada and International	1-888-WALINGA (ext 258)	warranty.canada@walinga.com
USA	1-800-466-1197 (ext 8)	warranty.usa@walinga.com
Australia	07-4634-7344	mail@customvac.com.au

SERVICE

Guelph, ON, Canada	1-888-WALINGA (ext 228)	guelph.service@walinga.com
Carman, MB, Canada	1-800-668-6344 (ext 418)	carman.service@walinga.com
Barrhead, AB, Canada	1-780-572-6082 (ext 1001)	todd.swaving@walinga.com
Wayland, MI, USA	1-800-466-1197 (ext 508)	wayland.service@walinga.com
Sioux Center, IA, USA	1-800-845-5589 (ext 804)	siouxcenter.service@walinga.com
Toowoomba, QLD, Australia	07-4634-7344	mail@customvac.com.au

ORIGINAL PARTS SALES

Eastern Canada and International	1-888-WALINGA (ext 224)	parts.canada@walinga.com
Western Canada	1-800-668-6344 (ext 421)	parts.carmen@walinga.com
Eastern USA	1-800-466-1197 (ext 507)	parts.usa@walinga.com
Western USA	1-800-845-5589 (ext 802)	parts.siouxcenter@walinga.com
Australia	07-4634-7344	parts.australia@walinga.com

SALES MANAGER

Tim Linde 1-519-787-8227 (ext 109) tim.linde@walinga.com

CORPORATE HEAD OFFICE

5656 Highway 6N
RR#5, Guelph, Ontario, N1H 6J2
Tel: 888-925-4642 Fax: 519-824-5651
www.walinga.com

FACTORY DISTRIBUTION AND SERVICE CENTERS

938 Glengarry Crescent, Fergus
Ontario, Canada N1M 2W7
Tel: 519-787-8227 Fax: 519-787-8210

1190 Electric Avenue, Wayland
Michigan, USA 49348
Tel: 800-466-1197 Fax: 616-877-3474

70 3rd Ave. NE Box 1790, Carmen
Manitoba, Canada R0G 0J0
Tel: 204-745-2951 Fax: 204-745-6309

579 4th St. NW, Sioux Center
Iowa, USA 51250
Tel: 800-845-5589 Fax: 712-722-1128

6116 46 St., Bloomsbury
Alberta, Canada T0G 0J0
Tel: 780-572-6082

24 Molloy St., Toowoomba
Queensland, Australia 4350
Tel: 07-4634-7344 Email: mail@customvac.com.au

Table of Contents

Contact Information [00-146431-0] - - - - -	<i>i</i>
Table of Contents [00-146431-0] - - - - -	<i>ii</i>
Literature Information [00-146431-0] - - - - -	<i>v</i>
Identification of Machine [00-146431-0] - - - - -	1-1
<i>Serial Numbers</i> - - - - -	1-2
Introduction [00-146432-0] - - - - -	2-1
<i>Statement of Importance</i> - - - - -	2-2
<i>Intended Use</i> - - - - -	2-2
<i>Directional References</i> - - - - -	2-3
<i>Smart-Flo in Pneumatic Conveying Systems</i> - - - - -	2-3
Machine Configuration [00-146433-0] - - - - -	3-1
<i>Model Sizes</i> - - - - -	3-2
Safety [00-146434-0] - - - - -	4-1
<i>Safety Alert Symbol</i> - - - - -	4-2
<i>Signal Words</i> - - - - -	4-2
<i>General Safety</i> - - - - -	4-3
<i>Pre-Operation Safety</i> - - - - -	4-4
<i>Electrical Safety</i> - - - - -	4-5
<i>Installation Safety</i> - - - - -	4-6
<i>Operational Safety</i> - - - - -	4-6
<i>Storage Safety</i> - - - - -	4-6
<i>Maintenance Safety</i> - - - - -	4-7
<i>Machine Safety Signs</i> - - - - -	4-7
<i>Safety Training Sign-Off Form</i> - - - - -	4-12

Machine Life-Cycle Procedures [00-146435-0] - - - - -	5-1
<i>Reception, Assembly and Initial Set-Up</i> - - - - -	5-2
<i>Storage</i> - - - - -	5-51
<i>End of Life</i> - - - - -	5-51
Operation [00-146436-0] - - - - -	6-1
<i>Machine Features and Components</i> - - - - -	6-2
<i>Controls and Displays</i> - - - - -	6-4
<i>Operation</i> - - - - -	6-29
<i>Pre-Operation Machine Preparation</i> - - - - -	6-29
<i>Operation of the Machine</i> - - - - -	6-29
<i>Stopping the Machine</i> - - - - -	6-30
<i>Troubleshooting</i> - - - - -	6-31
Maintenance and Adjustments [00-146437-0] - - - - -	7-1
<i>Maintenance Schedule</i> - - - - -	7-2
<i>Maintenance Safety</i> - - - - -	7-2
<i>Maintenance Procedures</i> - - - - -	7-3
<i>Adjustments</i> - - - - -	7-18
Specifications [00-146438-0] - - - - -	8-1
<i>Technical Data</i> - - - - -	8-2
<i>Wiring Diagram</i> - - - - -	8-3
<i>Bolt Torques</i> - - - - -	8-4
<i>Standards and Regulations</i> - - - - -	8-6
Warranty [00-145861-0] - - - - -	9-1
<i>The Warranty</i> - - - - -	9-2
<i>Warranty Period</i> - - - - -	9-2
<i>Limitations and Exclusions of the Walinga Warranty</i> - - - - -	9-2
<i>Warranty Claim Procedure</i> - - - - -	9-2

<i>Required Warranty Claim Information</i> - - - - -	9-3
<i>Warranty Conditions</i> - - - - -	9-3
<i>Warranty Claim Rejection</i> - - - - -	9-4
<i>Not Covered Under Warranty</i> - - - - -	9-4
Accessories and Attachments [00-146440-0] - - - - -	10-1
Parts List [00-146441-0] - - - - -	11-1
<i>Model Assemblies</i> - - - - -	11-2
<i>Individual Components</i> - - - - -	11-3

This manual contains important information regarding the safety, operation and maintenance of your Smart-Flo 2.0 system.

Some illustrations and diagrams may show safety shields, guards, or covers removed for clarity. **DO NOT** operate the system without these guards in place.

Identification of Machine

The identification of machine section outlines the applicable models included in this manual. It identifies the location of the machine serial number and serialized components and provides space for recording these numbers.

Introduction

The introduction section outlines the importance of this document and provides details for the interpretation and understanding of information presented in this manual.

Configuration

The configuration section gives an overview of the various configurations available for the specified model and identification between the different configurations.

Safety

The safety section lists important safety precautions and procedures as well as providing the meaning, location and visual representation of all safety signs and labels on the machine. Read and understand all precautions before operating, maintaining or transporting the system.

Machine Life-Cycle Procedures

The machine life-cycle procedures section provides information on the reception, assembly and initial set-up, storage, and end of life procedures.

Operation

The operation section gives general information on the operating principles including starting, operating functions, and stopping the system, as well as clearing any blockages. This section also provides troubleshooting information for fault diagnosis and solutions to issues that may be encountered.

Maintenance and Adjustments

The maintenance and adjustments section provides the recommended maintenance schedule and task instructions for calendar intervals. Maintenance should be performed minimally at this interval, or more frequently as required.

Specifications

The specifications section details technical data of the particular model to achieve a high standard of operational performance and outlines relevant standards and regulations.

Warranty

The warranty section outlines the terms and limitations of the warranty coverage.

Accessories and Attachments

The accessories and attachments section lists available attachments for the system.

Parts List

The parts list section provides information for the identification of replacement assemblies, subassemblies and parts.



Identification of Machine

SMART-FLO 2.0 SYSTEM

SERIAL NUMBERS

Be prepared to provide the serial number of the Smart-Flo system to your Walinga dealer or representative when ordering parts or requesting service or other information. For easy reference, record the required serial number as follows:

Smart-Flo System Serial Number

Located on the lower right surface of the control panel enclosure.

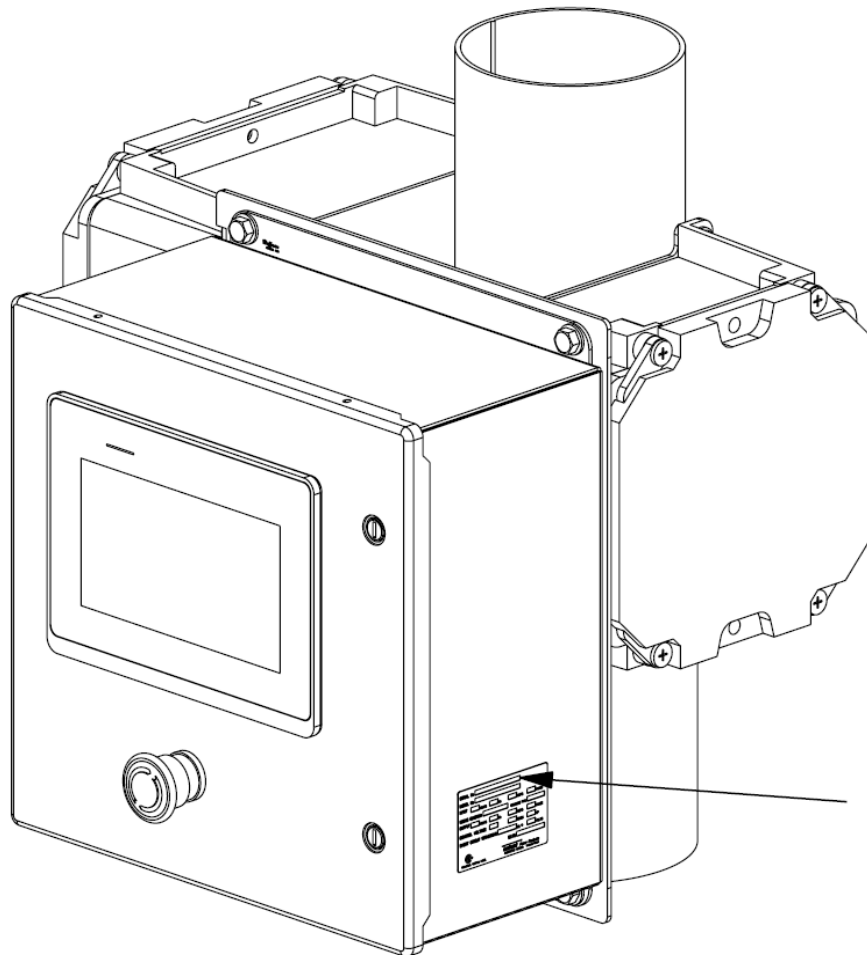

Figure 1-1: Serial number location



Introduction

SMART-FLO 2.0 SYSTEM

STATEMENT OF IMPORTANCE

Congratulations on your choice of a Walinga Smart-Flo system to complement your operation. This equipment has been designed, engineered and manufactured to meet the needs of the discriminating buyer for the efficient moving of bulk commodities.

Your safety and the performance of your system are Walinga's top priorities. This operator's manual has been created for the express purpose of keeping you safe and providing education for the efficient use of the Smart-Flo system.

Safe, efficient and trouble-free operation of your Smart-Flo system requires that you and any individuals operating or maintaining the system, read and understand all sections of this operator's manual. An operator who has not familiarized themselves with the contents of this manual constitutes an untrained operator. Untrained operators are not qualified to operate the system.

Keep this manual available for frequent reference and for provision to new operators or owners.

Your system's appearance or structural design may differ from illustrations shown in the manual. Continuous design improvements for optimized field performance are on-going and may have been made to your system since the publication of the manual. Specifications, descriptions and all other information in the manual are subject to change and/or correction without notice. Contact your local dealer or Walinga representative for the most current revision of your system's manual or if you have any questions.

INTENDED USE

Walinga's Smart-Flo system has been designed for use in agricultural or bulk commodity commercial operations. Use of the system in any other manner is considered as contrary to the intended use. Compliance with and strict adherence to the methods of operation, maintenance, and repair, as specified by Walinga in this manual, also constitute essential elements of the intended use.

The Smart-Flo system must be operated, maintained and serviced only by persons who are familiar with its particular characteristics and have been acquainted with the relevant safety procedures in this manual. Any individual who has not familiarized themselves with the content of this manual is considered untrained. Untrained persons are considered unqualified to operate, maintain or service a Smart-Flo system. It is the responsibility of the owner and/or operator to train new operators and ensure they have read and understood this manual.

Accident prevention regulations and all other generally recognized regulations on safety and occupational health and safety must be observed at all times.

Any unauthorized modifications carried out to the Smart-Flo system may relieve Walinga of liability for any resulting damage or injury and is considered contrary to the intended use.

DIRECTIONAL REFERENCES

The following directions will be used as a standard throughout the manual:

TOP	The inlet side of the air velocity sensor tube
BOTTOM	The outlet side of the air velocity sensor tube
FRONT	The control screen and electrical enclosure
REAR	The air velocity sensor tube
LEFT	The counterweight enclosure
RIGHT	The signal conditioner enclosure
FLOW	The air flow through the system is downwards

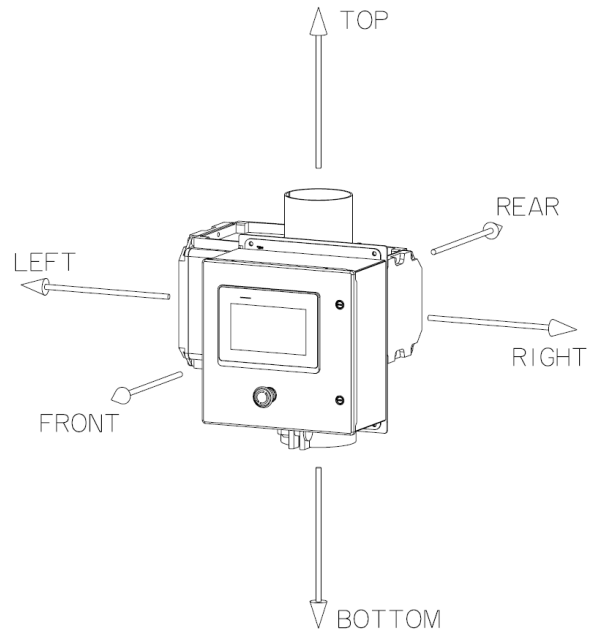

Figure 2-1: Directional references

SMART-FLO IN PNEUMATIC CONVEYING SYSTEMS

Pneumatic conveying systems use air to move materials, Walinga's Smart-Flo system is designed to control and optimize the conveyance of agricultural materials and bulk commodities. The Smart-Flo system is most commonly installed on a Walinga Ultra-Veyor system.

The Smart-Flo system is mounted on the inlet side of a blower. The air velocity sensor measures the flow of air into the pneumatic conveying system, and the live data is monitored by the programmable logic controller (PLC). The system may also monitor the pressure of the system with an optional pressure sensor. The PLC processes the data and signals the variable frequency drive (VFD) of the blower motor to adjust the blower speed accordingly. It is also capable of monitoring additional external sensors and signals such as bin level sensors and external run commands. The Smart-Flo control panel provides the run commands for both the blower as well as airlock VFDs and motors and also has a standard and emergency stop to shutdown the blower and airlock. The constant monitoring of air speeds and consequent blower speed adjustments optimize the pneumatic conveying system performance, maintain bulk integrity, and reduce energy costs.

A simplified representation of the function of the Smart-Flo system in a pneumatic conveying system can be seen in **Figure 2-2**.

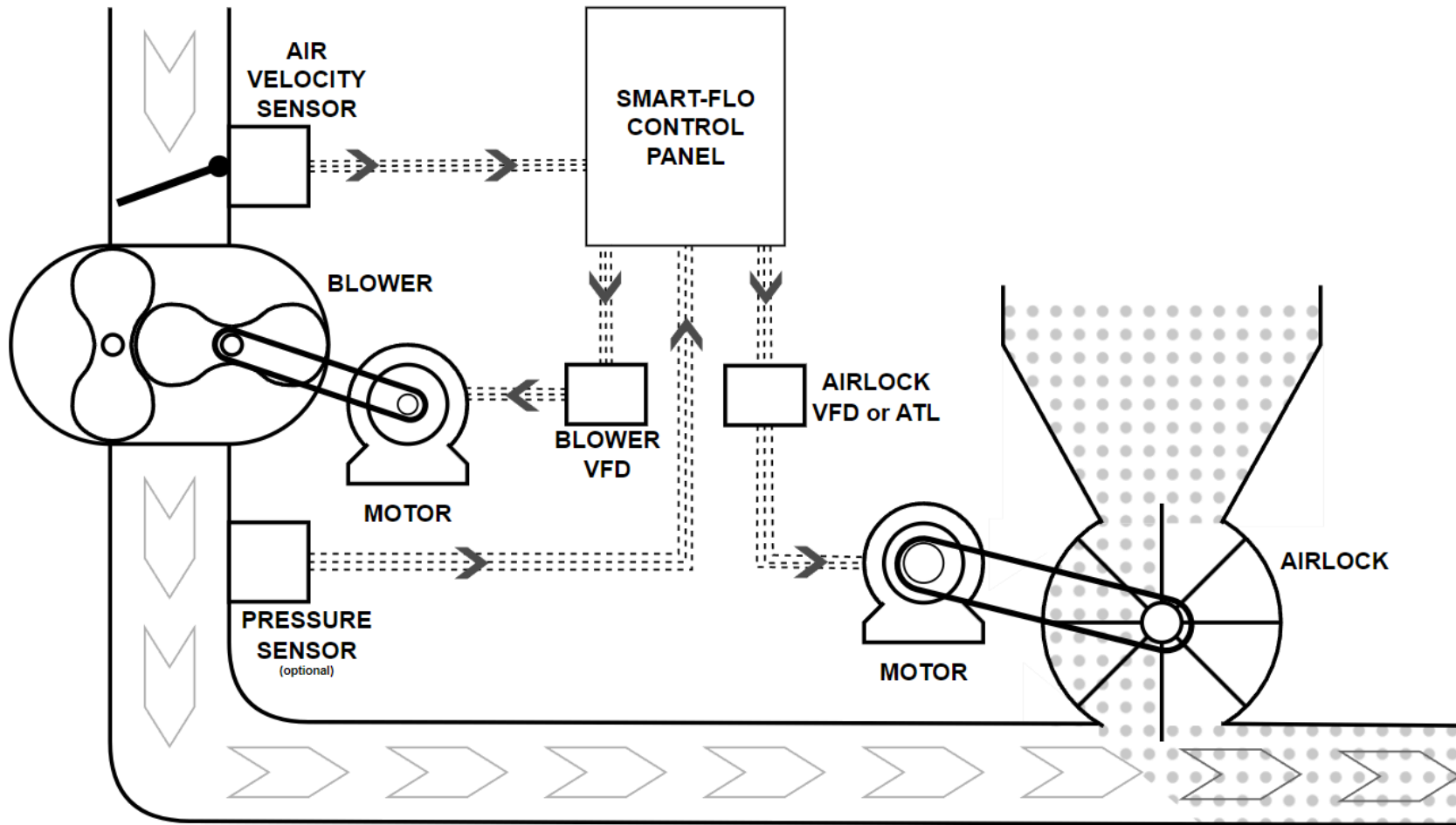

Figure 2-2: Smart-Flo simplified system



Machine Configuration

SMART-FLO 2.0 SYSTEM

MODEL SIZES

Walinga Smart-Flo systems are available in a variety of sizes to accommodate the full range of Walinga's pneumatic conveying systems. To identify the size of your Smart-Flo system, measure the diameter (D) of the air velocity sensor tube as seen in **Figure 3-1**.

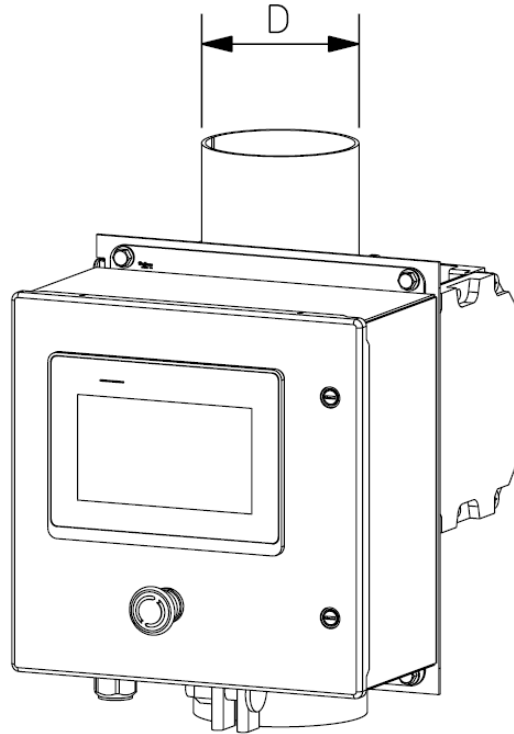

Figure 3-1: Model identification reference dimension



Safety

SMART-FLO 2.0 SYSTEM

SAFETY ALERT SYMBOL



This safety alert symbol means: **ATTENTION! BECOME ALERT! YOUR SAFETY IS INVOLVED!**

The safety alert symbol identifies important safety messages on the Smart-Flo system and in the operator's manual. When you see this symbol, be alert to the possibility of personal injury or death. Follow the instructions in the safety message.

Safety is one of the top priorities and should always be taken into consideration because:

- Accidents disable and kill
- Accidents cost
- Accidents can be avoided

SIGNAL WORDS

Take note of the signal words **DANGER**, **WARNING**, and **CAUTION** when used with a safety message, as well as the use of the words **IMPORTANT** and **NOTE**. The appropriate signal word for each message has been selected using the following guidelines:

DANGER	Indicates an imminently hazardous situation that, if not avoided, will result in death or serious injury. This signal word is limited to the most extreme situations, typically for machine components that, for functional purposes, cannot be guarded. The associated color is red.
WARNING	Indicates a potentially hazardous situation that, if not avoided, could result in death or serious injury, and includes hazards that are exposed when guards are removed. It may also be used to alert against unsafe practices. The associated color is orange.
CAUTION	Indicates a potentially hazardous situation that, if not avoided, may result in minor or moderate injury. It may also be used to alert against unsafe practices. The associated color is yellow.
IMPORTANT	Indicates a potentially hazardous situation that, if not avoided, may result in damage to the machine. It may also be used to alert against unsafe practices. The associated color is blue or white.
NOTE	Indicates supplementary information that the operator must be aware of for the safe or proper use of the machine. The associated color is blue or white.

GENERAL SAFETY

You are responsible for the **safe** operation and maintenance of your Smart-Flo system. **You** must ensure that you and anyone else who will operate, maintain, or work around your pneumatic conveying equipment is familiar with the operating and maintenance procedures and safety information contained in this manual. This manual will provide information for safety practices that must be adhered to while operating a Smart-Flo system. Remember, **you** are the key to safety. Good safety practices not only protect you, but also the people around you. Make good safety practices a working part of your safety program. Be certain that **everyone** operating the pneumatic conveying equipment is familiar with the recommended procedures and follows all safety precautions. Remember, most accidents can be prevented; do not risk injury or death.

Owners must provide operating instructions to operators or employees before initially allowing them to operate the equipment, and must review this information at least annually thereafter. The most important safety feature of Walinga equipment is a **safe** operator. It is the operator's responsibility to read and understand all aspects of this manual and to follow all safety and operational instructions. An individual who has not read, understood, and been trained to follow all operation and safety procedures is considered an untrained operator and is unqualified and unauthorized to operate a Smart-Flo system. Untrained operators expose themselves and bystanders to potential serious injury or death.

Before servicing, adjusting, or repairing a Smart-Flo system, place all controls in the neutral or off position, disconnect and lock-out all power sources including those to the control panel, blower and airlock, and wait for all moving parts to stop.

In case of emergency, keep a first-aid kit and fire extinguisher readily available and stored in a highly visible place. Be familiar with the use of each of these tools. Keep the phone number for the emergency medical center for your area readily available.

Use appropriate personal protective equipment including, but not limited to: a hard hat, protective shoes with slip-resistant soles, protective glasses or goggles, heavy gloves, wet weather gear, and hearing protection. Long hair and loose clothing must be secured to avoid potential injury as a result of coming into contact with moving or rotating components. Hands and feet must also be kept clear of any moving or rotating components.

Ensure all electrical equipment is properly grounded. All electrical connections made to the system must be in compliance and accordance with the National Electric Code (NFPA 70).

In order to provide a better view or visualization, certain diagrams in this manual may show an assembly or machine feature with a safety shield or guard removed. This is for illustrative purposes only. Equipment must never be operated in this condition. Keep all guards and shields in place. If it is necessary to remove a shield or guard for maintenance or adjustment, the shield or guard must be installed and secured prior to use.

Replace any safety sign or instructional sign that has been damaged or become illegible. The most common locations and a reproduction of the safety signs located on the Smart-Flo system are outlined later in this section. In addition to the design and configuration of this implement, including safety signs and safety equipment, hazard control and accident prevention are dependent upon the awareness, concern, prudence, and proper training of personnel involved in the operation, transport, maintenance, and storage of the machine. Refer to the safety messages and operational instructions in each of the appropriate sections of the auxiliary equipment and machine manuals. Pay careful attention to the safety signs affixed to the auxiliary equipment and the machine.

Never use alcoholic beverages, narcotics, or other intoxicants which could hinder alertness or coordination while operating a Smart-Flo system. Consult your doctor about operating this system while taking prescription medications.

Under no circumstances should young children be allowed to work with this equipment. Do not allow children or any other individuals to climb on or play around the system at any time. This equipment is dangerous to children and individuals unfamiliar with its operation. The operator must be a responsible, properly trained, and physically able person familiar with farm and/or industrial machinery and trained in the system's operation. If there are elderly individuals assisting with work, their physical limitations must be recognized and accommodated. Do not allow any individuals to operate or assemble this machine until they have read and understood the safety precautions and operational procedures in this manual.

Never exceed the limits of a piece of machinery. If its ability to perform a task, or to do so safely, is in question, do **not** attempt it. Do not modify the equipment in any way. Unauthorized modification may result in serious injury or death and may impair the function, safety or life of the equipment, as well as void the warranty.

PRE-OPERATION SAFETY

- Safety is a primary concern in the design and manufacturing of Walinga products. However, these efforts can be negated by a single careless act of an operator or bystander.
- It is the responsibility of the operator to read and understand all safety and operational instructions contained within the operator's manual and the manuals of any auxiliary equipment. Working with unfamiliar equipment can lead to careless injuries. Ensure you and any individual who will be working with or around the Smart-Flo system understands the information provided in the operator's manuals and is instructed in the safe and proper use of the machine.
- Refer to the auxiliary equipment's operator's manual to become familiar with the controls of the auxiliary equipment and know how to stop any auxiliary equipment quickly in the event of an emergency.

- Properly train all new personnel and review instructions frequently with existing workers. Ensure only a properly trained and physically able individual will operate the machine. Any individual who has not read and understood all operating and safety procedures is not qualified to operate the machine.
- Ensure all necessary personal protective equipment including a hard hat, safety glasses or goggles, safety shoes, gloves, wet weather gear, and hearing protection are in good condition. Do not allow loose long hair, loose fitting clothing, or jewelry to be around the equipment. Prolonged exposure to loud noise may cause permanent hearing loss. Motors or other auxiliary equipment can often produce enough noise to cause permanent, partial hearing loss. It is recommended that hearing protection is always used if the noise levels at the operator's position exceed 80 dB. Noise over 85 dB on a long-term basis can cause severe hearing loss. Noise over 90 dB in close proximity to the operator over a long-term basis may cause permanent, total hearing loss. Hearing loss from loud noise is cumulative over a lifetime and with no chance of natural recovery.
- Clear the working area of debris, trash or hidden obstacles that may be hooked or snagged, causing injury, damage or tripping hazards.
- Operate only in daylight or with sufficient artificial lighting.
- Ensure the machine is properly anchored, adjusted and in good operating condition. Check the machine over for any loose bolts, worn parts, cracks, leaks, etc., and make any necessary repairs. Always follow the maintenance instructions.
- Ensure that all safety shielding and guarding and safety signs are properly installed and secured, and are in good condition.

ELECTRICAL SAFETY

- For any required electrical connections, ensure that sufficient amperage at the proper voltage and frequency is available before connecting power. Have a licensed electrician provide power to the machine. Always follow ANSI/NFPA 70 standard, the National Electric Code, and all local codes and regulations when providing electrical power.
- Ground all electrical equipment and ensure the power source is properly grounded.
- Use only the supplied or approved motor and starter. Never use a motor that is not sufficiently rated to operate the equipment.
- Review the operator's manual for the motor and starter.
- Ensure all electrical switches on the equipment are in the OFF position before connecting the equipment to power.
- Turn the equipment OFF, shut-down and lock-out all power supplies and wait for all moving parts to stop before servicing, adjusting, or lubricating equipment.
- Disconnect from the power supply before resetting any motor or breaker overload.
- Replace any damaged electrical plugs, cords, switches or components immediately.

INSTALLATION SAFETY

- Disconnect and remove all mechanical locks, anchor chains and any other transport devices that would hinder or prohibit the normal function of the airlock upon start-up. Serious damage to the machine and/or personal injury to the operator or bystanders may result from attempting to operate the machine while mechanical locking devices are still attached and secured.
- Ensure there is a minimum of one additional individual available for assistance with elevating, moving, or connecting other equipment.
- For any required electrical connections, ensure that sufficient amperage at the proper voltage and frequency is available before connecting power. Have a licensed electrician provide power to the machine. Always follow ANSI/NFPA 70 standard, the National Electric Code, and all local codes and regulations when providing electrical power.

OPERATIONAL SAFETY

- Read and understand the operator's manual and all safety signs before use.
- Do not operate when any guards are damaged or removed. Install and secure all guards before operating.
- Do not open any access door to the system or components while in operation.
- Keep hands, feet, clothing, hair, and jewelry away from all moving and/or rotating parts.
- Do not allow any individuals to climb on the airlock at any time.
- Clear the area of all bystanders, especially small children, before operation.
- Keep all safety signs clean and unobstructed.
- Wear appropriate personal protective equipment while operating.
- Establish a formal Lock-Out Tag-Out program for your operation and train all operators and service personnel before allowing them to work with or around the pneumatic conveying system. Provide tags and a sign-up sheet to record tag-out details.
- In the event of a blockage in any auxiliary component, disconnect and lock-out all power sources before any guards or access points are opened to manually dislodge obstructions.

STORAGE SAFETY

- Store the equipment in an area away from human activity.
- The storage area should be dry with a firm, level surface, and indoors.
- Do not permit children to play on or around the stored equipment.
- Ensure all mechanical locks are safely and positively connected.
- Lock-out all power supplies to prevent unexpected or unintentional start-up.

MAINTENANCE SAFETY

- Read, understand and follow all operating, maintenance and safety information in the operator's manual.
- Clear the area of bystanders, especially small children, when carrying out any maintenance or repairs or making any adjustments.
- Follow good shop practices:
 - Keep the service area clean and dry.
 - Ensure electrical outlets and tools are properly grounded.
 - Use adequate lightning for the job at hand.
- Ensure a fire extinguisher and first aid kit are available, and know how to use them.
- Place all controls in neutral, stop and lock-out the power source, and wait for all moving parts to stop before servicing, adjusting or maintaining.
- Establish a formal Lock-Out Tag-Out program for your operation and train all operators and service personnel before allowing them to work with or around the pneumatic conveying system. Provide tags and a sign-up sheet to record tag-out details. Do not perform any service or maintenance work unless any auxiliary motors are OFF and all power supplies are locked-out. Safety lock-out devices are available through your Walinga dealer's parts department.
- Use the required personal protective equipment previously outlined.
- Use only tools, jacks and hoists of sufficient capacity for the job.
- Keep hands, feet, hair, clothing, and jewelry away from all moving and/or rotating parts.
- Ensure all guards are in place and secured when maintenance work is complete.

MACHINE SAFETY SIGNS

The safety signs affixed to the Smart-Flo system and auxiliary equipment provide important information regarding your safety and the safe operation of the equipment. Familiarize yourself with all safety signs before operation.

- Safety signs must be clean and legible at all times.
- Replace any safety signs that are missing, damaged, or have become illegible.
- Any replaced parts that previously displayed a safety sign, must display the current safety sign.
- Safety signs are available at no cost from your representative, dealer, or directly from Walinga.

If a safety sign has become damaged, illegible or a new safety sign must be installed on a replacement component, proceed as follows:

1. Ensure the installation area is clean and dry
2. Ensure the temperature of the equipment is above 50 °F (10 °C).
3. Locate the correct position of the safety sign before removing the backing paper.
4. Remove the smallest portion of the split backing paper.
5. Align the safety sign over the correct position and carefully press the small portion with the exposed adhesive backing in place.
6. Slowly peel back the remaining paper and carefully smooth the remaining portions of the safety sign in place.
7. Small air pockets can be pierced with a pin and smoothed out using the backing paper.

Safety signs affixed to pneumatic conveying equipment are standardized as follows:

- Danger safety signs are red in color
- Warning safety signs are orange in color
- Caution safety signs are yellow in color
- Informational safety signs are white or blue in color
- Each safety sign is printed with its respective Walinga part number located in the bottom right corner. Reference this number on the safety sign, or identified in the following reproductions, to obtain replacement safety signs.

Due to the wide variety and configurations of pneumatic conveying systems that utilize a Smart-Flo system, refer to the operator's manual of the auxiliary equipment for the exact location, quantity and part number of each safety sign. The following safety signs are commonly used in close proximity and in relation to the Smart-Flo system:

Figure 4-1

Approximate Location:

Located on the upper right surface of the control panel enclosure.

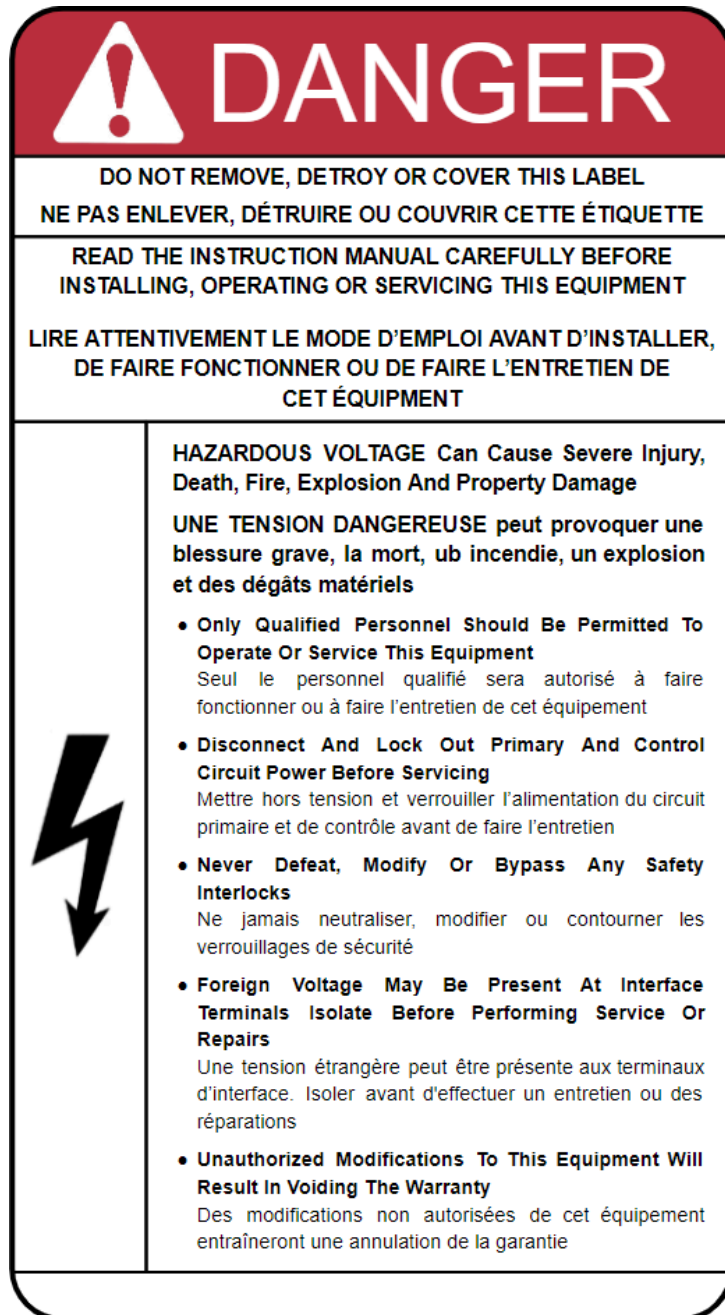

Figure 4-2

Part Number: 53-82427-6

Approximate Location:

Located on the back of the air velocity sensor tube, oriented to show the flow in the downward direction.

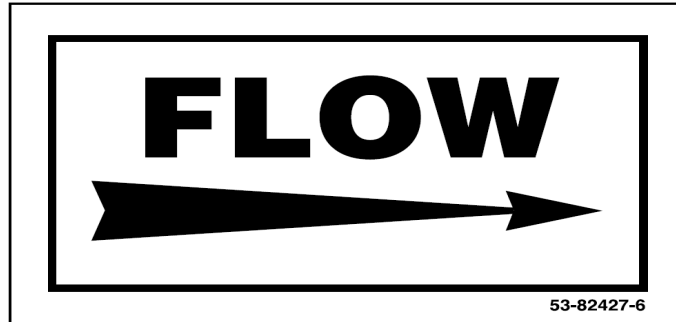

Figure 4-3

Part Number: 53-143826-6

Approximate Location:

Located on the protective plastic shipping covering. To be removed upon removal of protective covering during installation.

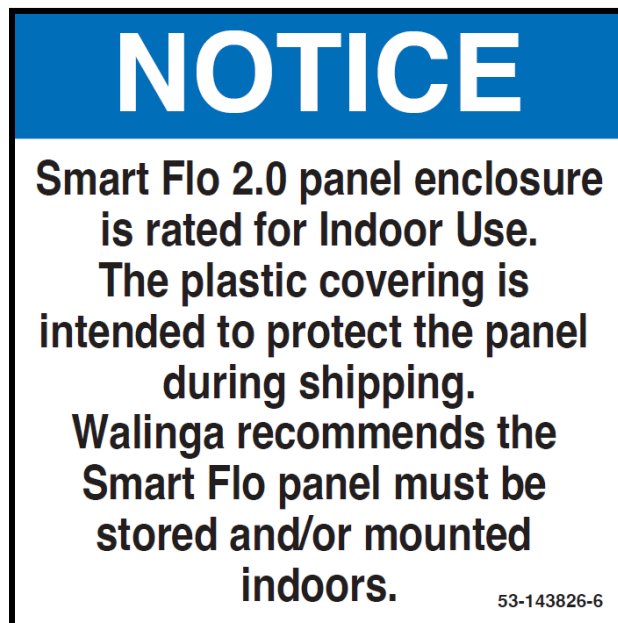

Figure 4-4

Part Number: 53-137792-6

Approximate Location:

Located on the left surface of the control panel enclosure.



Figure 4-5

Part Number: 53-146675-6

Approximate Location:
Located on the inner surface of the control panel enclosure door.



Figure 4-6

Part Number: 53-144875-6

Approximate Location:
Located on the outer surface of the control panel enclosure door.

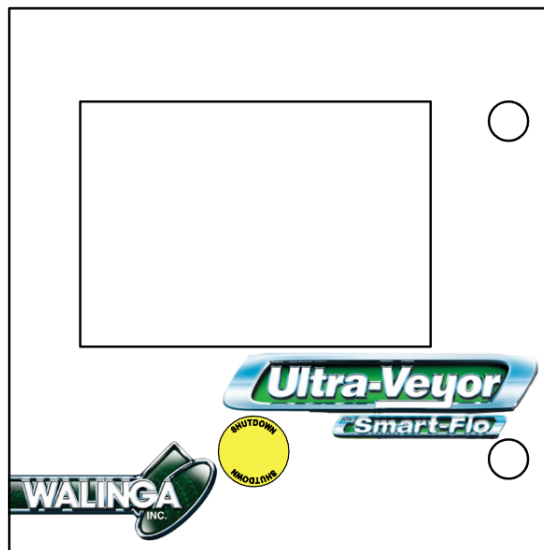



Figure 4-7

Approximate Location:
Located on the lower right surface of the control panel enclosure.

SERIAL No	<input type="text"/>		
MODEL No	<input type="text"/>		
INPUT	<input type="text"/> VOLTS	<input type="text"/> Hz	<input type="text"/> AMPS <input type="text"/> PHASE
WIRING DIAGRAM	<input type="text"/>	ENCLOSURE TYPE	<input type="text"/>
OUTPUT	<input type="text"/> VOLTS	<input type="text"/> Hz	<input type="text"/> AMPS <input type="text"/> PHASE
CONTROL VOLTAGE	<input type="text"/>	<input type="text"/> WIRES	<input type="text"/> HP
SHORT CIRCUIT WITHSTAND	<input type="text"/> KA @	<input type="text"/> VOLTS	
		DATE:	<input type="text"/>

 INDUSTRIAL CONTROL PANEL

SAFETY TRAINING SIGN-OFF FORM

Walinga Inc. follows the general safety standards specified by the American Society of Agricultural Engineers (ASAE) and the Occupational Safety and Health Administration (OSHA). Anyone who will be operating and/or maintaining the Smart-Flo system must read and clearly understand all safety, operating and maintenance information presented in this manual.

Do not operate or allow any other individual to operate this equipment until such information has been reviewed. Annually review this information with personnel.

Make periodic reviews of safety and operations a standard practice for all equipment. An untrained operator is unqualified to operate a Smart-Flo system.

The following sign-off sheet is provided for record keeping to show that all personnel who will be working with the equipment have read and understand the information in the operator's manual and have been instructed in the operation of the equipment.

DATE	EMPLOYEE'S NAME	EMPLOYEE'S SIGNATURE	EMPLOYER'S SIGNATURE

DATE	EMPLOYEE'S NAME	EMPLOYEE'S SIGNATURE	EMPLOYER'S SIGNATURE



PAGE INTENTIONALLY LEFT BLANK



Machine Life-Cycle Procedures

SMART-FLO 2.0 SYSTEM

RECEPTION, ASSEMBLY AND INITIAL SET-UP

RECEPTION

Upon initial reception of the Smart-Flo system, move the system to the indoor area in which the system is to be installed. The Smart-Flo system must be installed indoors to prevent damage from the sun, water, or other elements. Once indoors, and after all necessary preparations have been made for installation, the protective plastic shipping covering may be removed.

ASSEMBLY

To ensure safe and efficient assembly and operation, proceed as follows:

1. Ensure the area is clear of any bystanders and individuals not involved in the assembly or operation of the equipment, especially small children.
2. Ensure the dust hazard analysis, as required by NFPA 652, has been completed and the incorporation of the Walinga equipment complies with all relevant standards and regulations.
3. To maintain proper stability, ensure all equipment is located on a flat surface that is solid, dry, and clear of any other equipment, and that all equipment has been properly anchored if required.
4. Ensure that any individuals involved in the assembly or operation of the system or in close proximity to the system are equipped with the required personal protective equipment as outlined in **Section 4: Safety**, including but not limited to: a hard hat, protective shoes with slip-resistant soles, protective glasses or goggles, heavy gloves, wet weather gear, and hearing protection. Long hair and loose clothing must be secured and jewelry should be removed to avoid personal injury as a result of contact with moving or rotating components.
5. Upon complete assembly, ensure all guards are correctly positioned, closed and secured before operation to prevent any personal injury or damage. All guards must be closed and secured with fasteners before any operation.
6. Ensure all mechanical locks, anchor chains, and any other transport devices that would hinder or prevent normal function or movement of the Smart-Flo system are removed. Serious damage to the system and/or personal injury to the operator or bystanders may result from attempting to operate the system while mechanical locking devices are attached.

For proper functionality, the Smart-Flo system must be mounted on the inlet of the blower. A variety of accessories are available for the blower inlet, refer to **Figure 5-1** through **Figure 5-3** for the correct configurations for mounting the Smart-Flo system with various accessories.

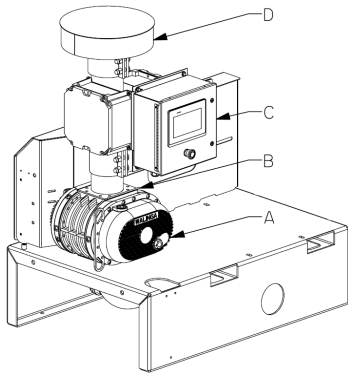
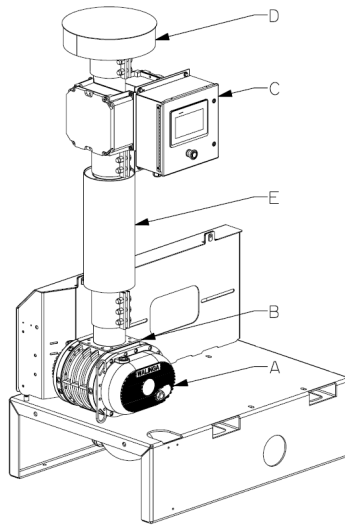
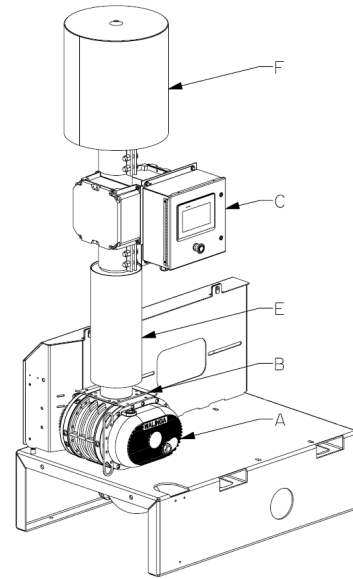
**Figure 5-1: Configuration 1****Figure 5-2: Configuration 2****Figure 5-3: Configuration 3**

In **Figure 5-1**, the order of components, from bottom to top is as follows: blower (A), blower inlet plate assembly (B), Smart-Flo system (C), and the inlet hat assembly (D).

In **Figure 5-2**, the order of components, from bottom to top is as follows: blower (A), blower inlet plate assembly (B), muffler assembly (E), Smart-Flo system (C), and the inlet hat assembly (D).

In **Figure 5-3**, the order of components, from bottom to top is as follows: blower (A), blower inlet plate assembly (B), muffler assembly (E), Smart-Flo system (C), and inlet filter assembly (F).

To mount the Smart-Flo system to a blower package assembly, proceed as follows:

1. Clear the area of bystanders, especially small children.
2. Place all controls in the neutral or off position, disconnect and lock-out all power sources including those to the control panel, blower and airlock, and wait for all moving parts to stop.
3. Remove the protective plastic shipping covering from the Smart-Flo system.
4. If equipped, remove any shipping coverings from the blower assembly.
5. Thoroughly inspect the Smart-Flo system, ensuring no damage has occurred to any components during shipping and that the system is clear of any dirt, dust or debris.
6. Inspect the blower package assembly to ensure it is clear of dirt, dust and debris. Clean as required.

7. With reference to **Figure 5-1** through **Figure 5-3**, loosen the compression coupling at the bottom of the Smart-Flo system and position it above the component to which it will be mounted. Ensure the arrow of the *FLOW* decal (53-82427-6) is pointed downwards.

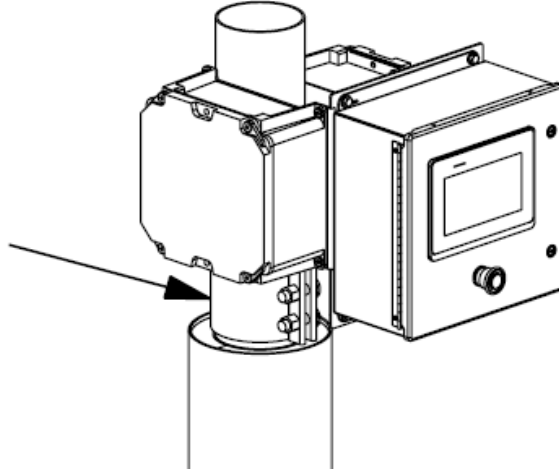

Figure 5-4: Smart-Flo system positioning

8. Tighten the compression coupling, ensuring both the air velocity sensor tube of the Smart-Flo system and the tube of the lower component are secure within the clamp. Do not overtighten the compression coupling as it may result in warping of the sensor tube, affecting system performance.
9. Position a second compression coupling at the top of the air velocity sensor tube and mount the remaining components above the Smart-Flo system.

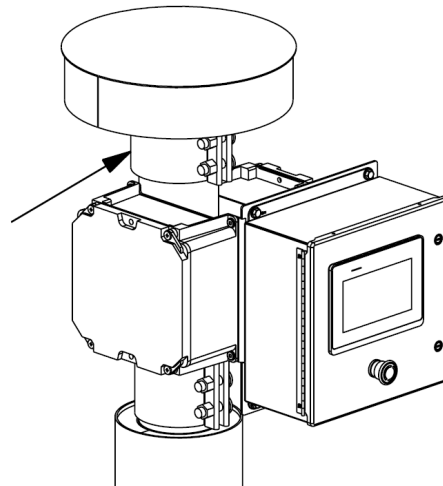

Figure 5-5: Compression coupling positioning

For all required electrical connections, ensure that sufficient amperage at the proper voltage and frequency is available, the requirements can be found below the serial number on the outer surface of the control panel enclosure. Have a licensed electrician provide power to the system. Always follow ANSI/NFPA 70 standard, the National Electric Code, and all local codes and regulations when providing electrical power.

For ease of access, installation, and to ensure proper connection and function, all external connections must be made using the appropriately labeled terminal of the terminal block. All required connections to the terminal block from the internal components of the control panel have been made by Walinga during production. Install a push-in choke seal for each wire required for external connections to the control panel enclosure.

To wire the external connections to the Smart-Flo system, proceed as follows:

1. Clear the area of bystanders, especially small children.
2. Place all controls in the neutral or off position, disconnect and lock-out all power sources, and wait for all moving parts to stop.
3. Review the electrical schematic for the system, as seen in **Figure 5-6** to **Figure 5-8**, and familiarize yourself with the components and their locations in your system. Reference **Table 5-1** for the terminal naming conventions of common VFD models.

Table 5-1: VFD terminal labels

	VF-S15	VF-AS1	VF-AS3	ATV320	C2000	A510	ACS580
Run	F	F	F	DI1	FWD	S1	DI1
Digital Common	CC	CC	CC	DQ+	DCM	24VG	+24V
Frequency	VAC	VI/II	II	AI3	ACI	AI2	AI1
Analog Common	CC	CCA	CC	COM	ACM	GND	AGND
NO Relay Contact	FLA	FLA	FLA	R1A	RA1	R1A	RO3B
Common Relay Contact	FLC	FLC	FLC	R1C	RC1	R1C	RO3C
Low-Speed NO Contact	RY	—	R1A	R2A	RA2	R2A	RO2B
Low-Speed Common Contact	RC	—	R1C	R2C	RC2	R2C	RO2C

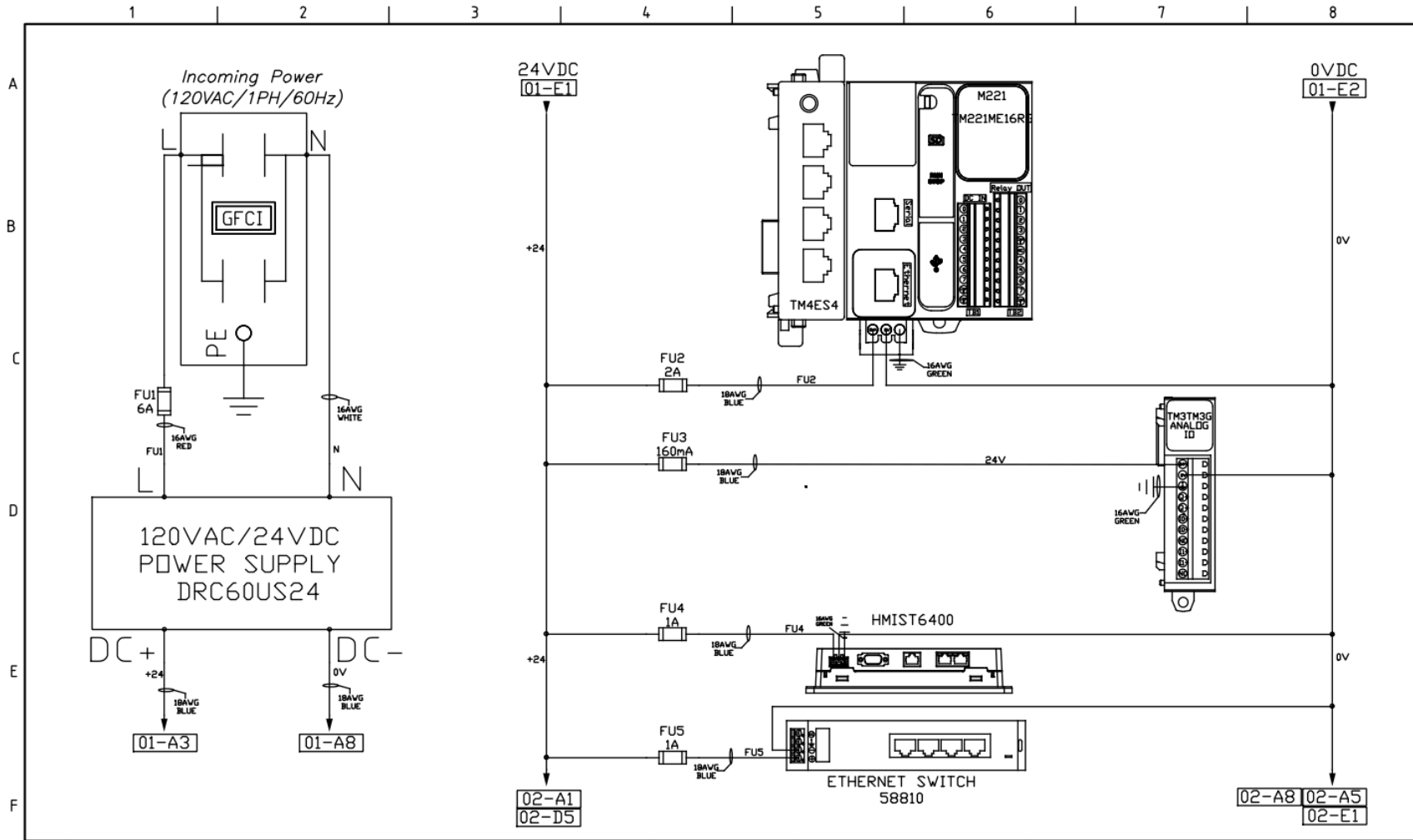

Figure 5-6: Smart-Flo system power distribution electrical schematic

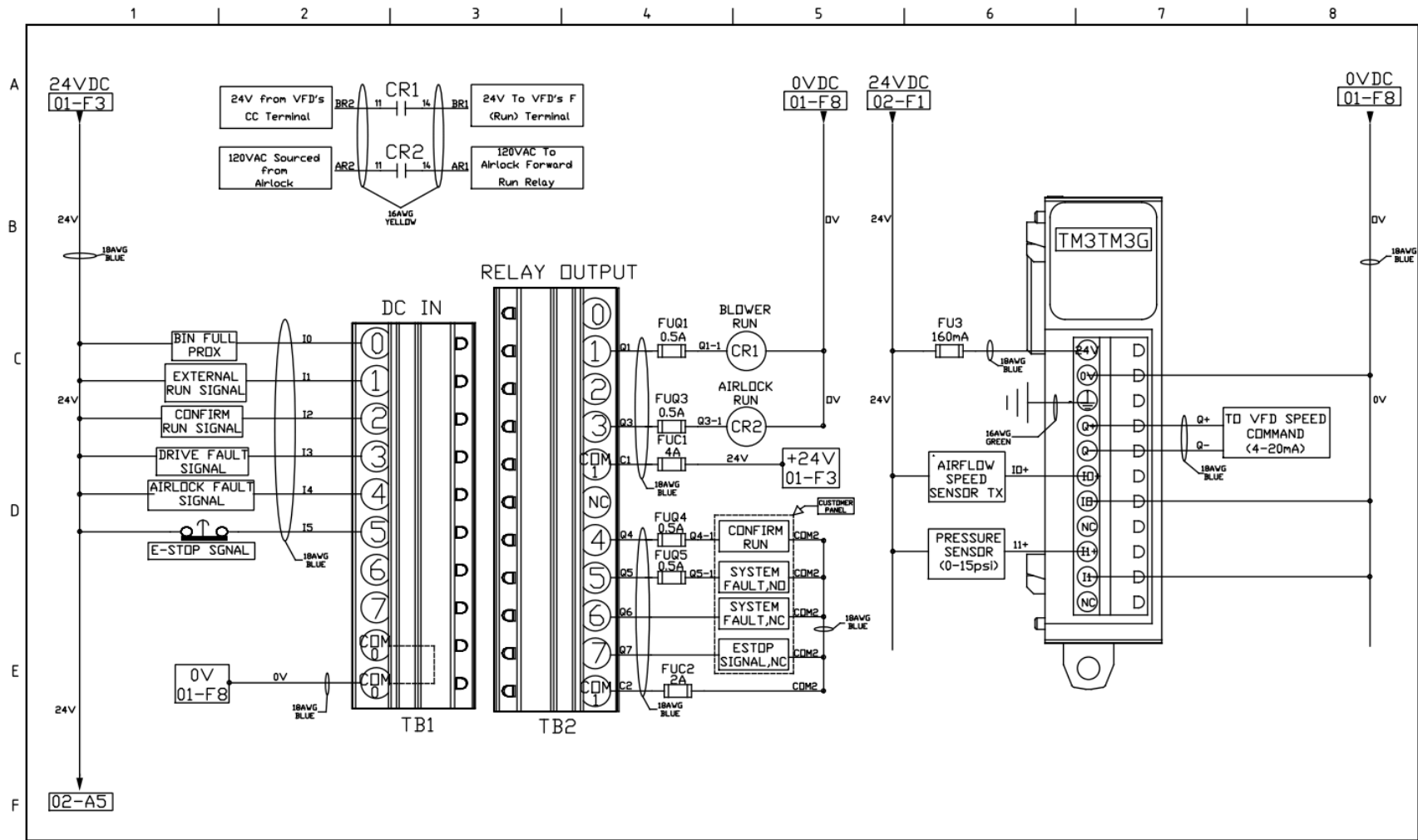

Figure 5-7: Smart-Flo system PLC I/O electrical schematic

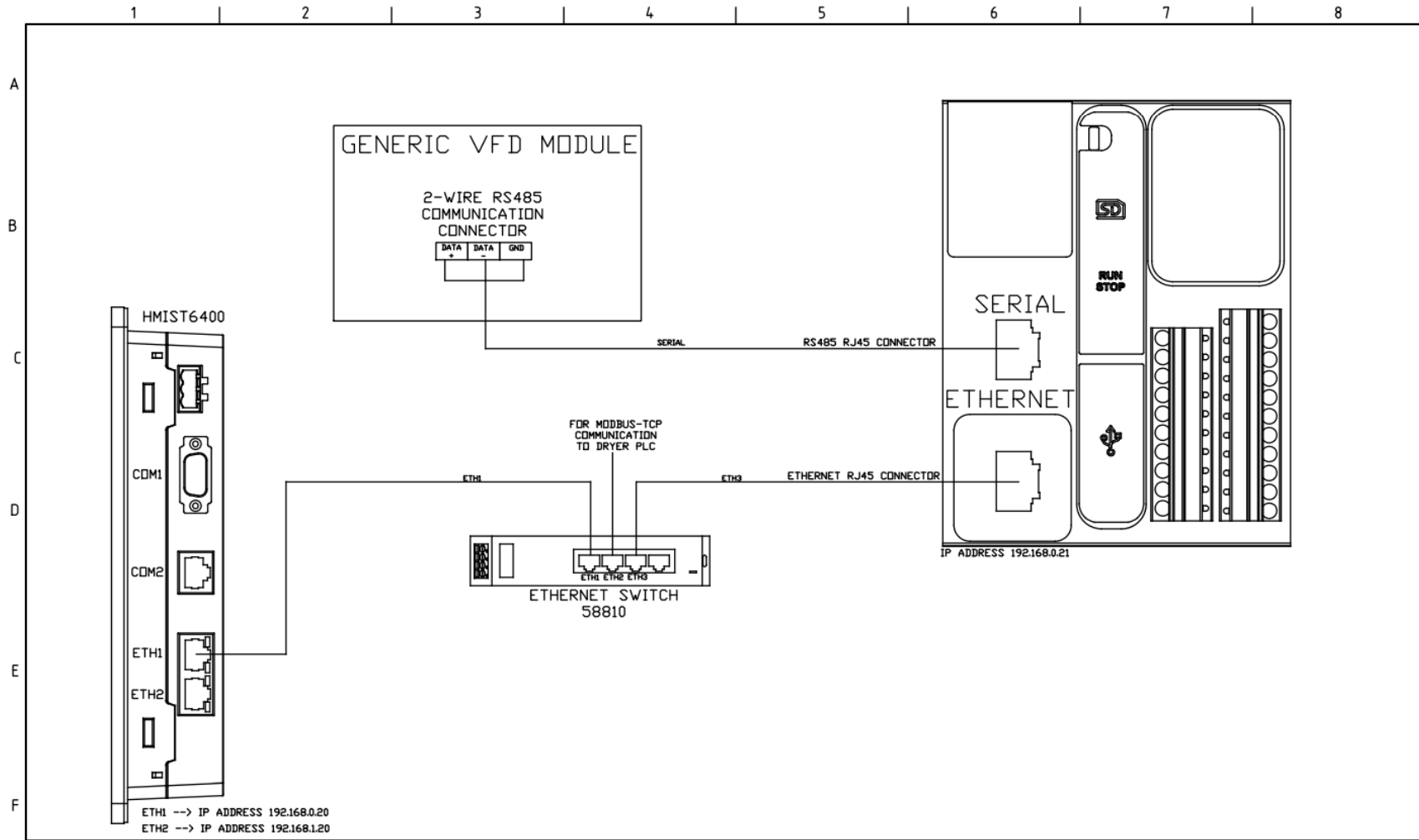

Figure 5-8: Smart-Flo system network distribution electrical schematic

4. Rotate the two enclosure latches a quarter turn and open the enclosure door.

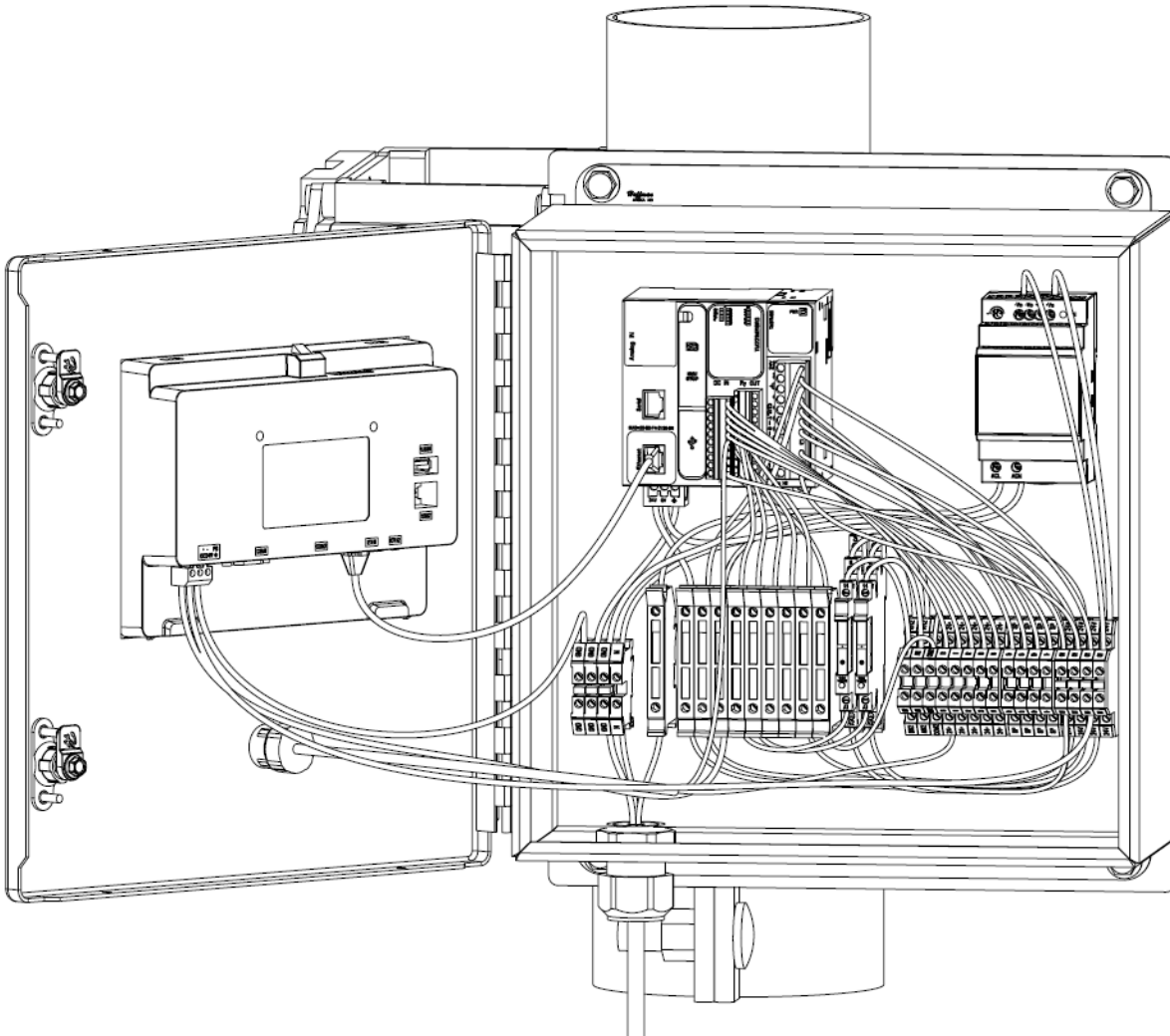

Figure 5-9: Control panel enclosure access

5. Connect the Modbus Control as follows:

NOTE: Modbus control is to be used for all applications which use a variable frequency drive with Modbus presets. Analog control is only to be used in applications for which the selected drive does not have any Modbus presets.

- a. For all VFD models excluding the ABB ACS580, complete **Step 5b** to **Step 5d**. For the ABB ACS580, proceed to **Step 5e**.
- b. Prepare an RS-485 cable, an ethernet cable may also be used. If required, prepare a two-wire to four-wire adapter cable. If Modbus TCP/IP is to be used, an ethernet switch installed in the PLC will also be required.
- c. Connect the RS-485 cable from the **SERIAL** port on the PLC to the RS-485 port on the blower VFD.

NOTE: if the RS-485 port on the blower VFD uses four-wire communication, an adapter is required. Insert the cable from the PLC **SERIAL** port into the female end of the adapter and insert the male end of the adapter into the port on the blower VFD.

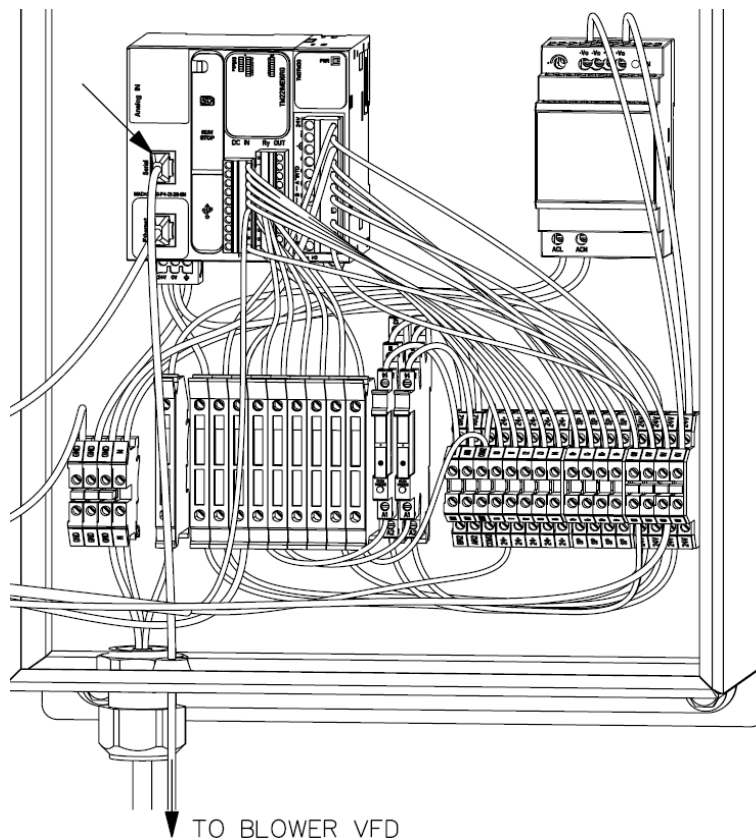

Figure 5-10: Modbus control PLC connection

- d. Proceed to **Step 6**.

- e. For the ABB ACS580 connect the Modbus Control following **Step 5f** to **Step 5h**.
- f. Prepare an RJ45 cable equipped with flying leads and identify the wire colors connected to pin 4, 5 and 8 with reference to **Figure 5-11**.

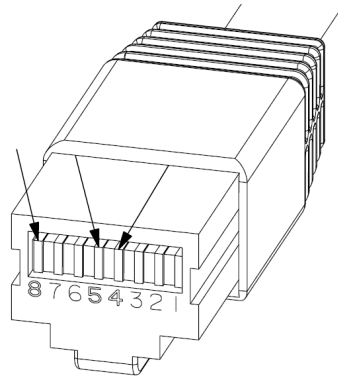

Figure 5-11: RJ45 pinout

- g. Connect the RJ45 cable to the Embedded Fieldbus (X5) section of the ABB ACS580 VFD as follows:
 - i. Connect pin **4** to terminal **29**.
 - ii. Connect pin **5** to terminal **30**.
 - iii. Connect pin **8** to terminal **31**.

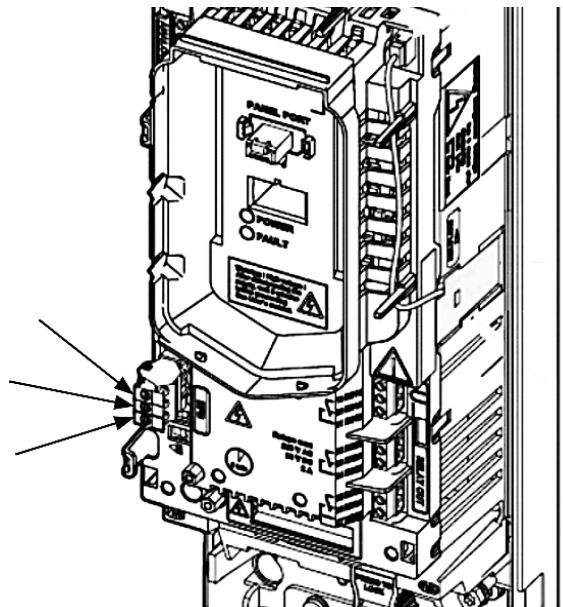

Figure 5-12: ABB ACS580 connection terminals

- h. Plug the RJ45 connector into the PLC **SERIAL** port.

6. To establish Analog communication and to complete the Modbus communication, proceed with **Step 7** through **Step 10**.
7. Connect the PLC digital outputs as follows:

NOTE: Use a minimum of 22 AWG wire to connect digital outputs.

 - a. **Blower Run** command
 - i. Prepare a two-wire cable (minimum 22 AWG, shielded wire preferred).
 - ii. Connect **BR1** to the **Run** terminal on the blower VFD.
 - iii. Connect **BR2** to the **Digital Common** terminal on the blower VFD.

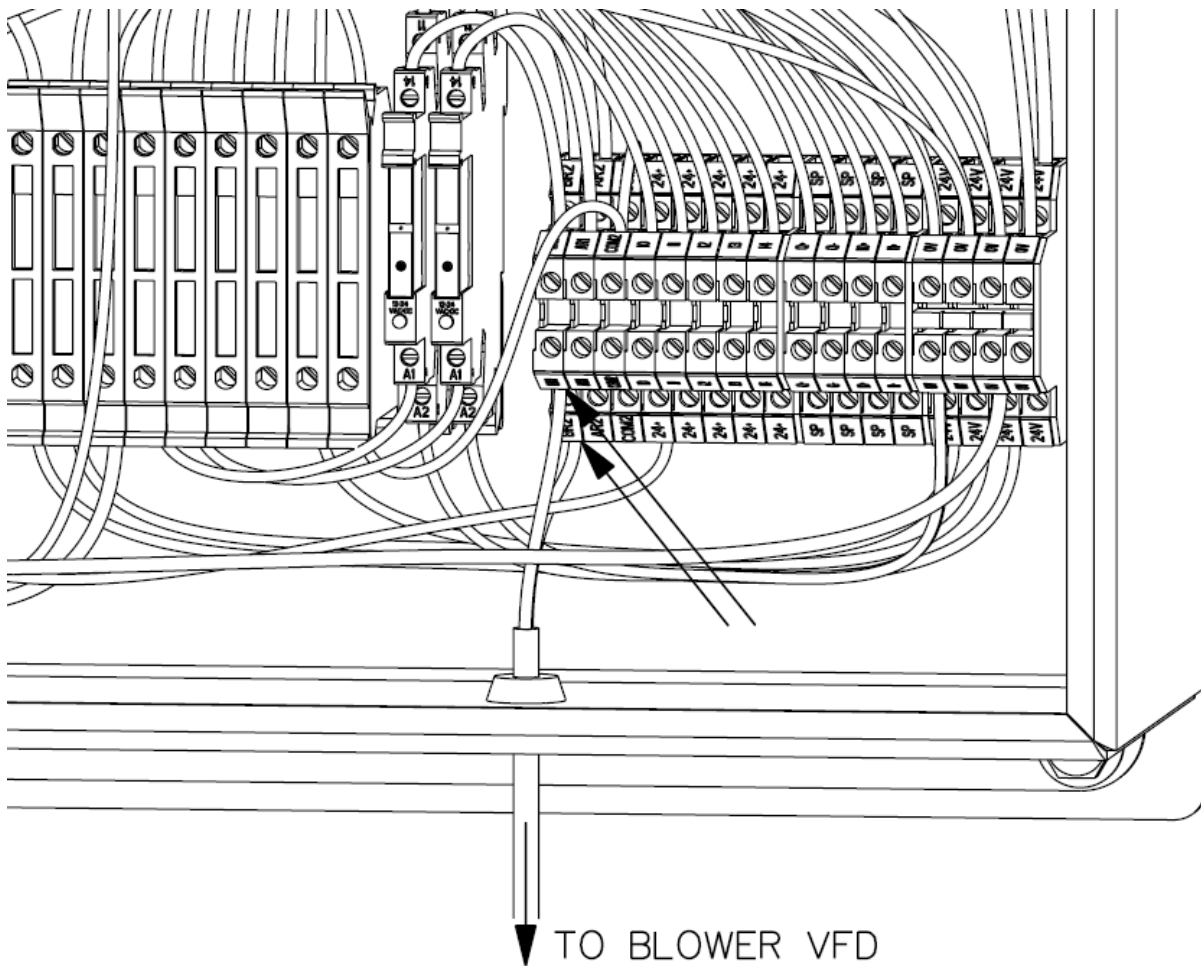

Figure 5-13: Blower VFD run command terminal connections

b. Airlock Run command

- i. Prepare a two-wire cable (minimum 22 AWG, shielded wire preferred).
- ii. Connect **AR1** to the **Run** terminal on the airlock VFD.
- iii. Connect **AR2** to the **Digital Common** terminal on the airlock VFD.
- iv. If the system uses an airlock starter in place of an airlock VFD, connect **AR1** and **AR2** to the Forward Run Signal of the airlock starter, often connected to the contactor coil which is commonly 110 VAC.

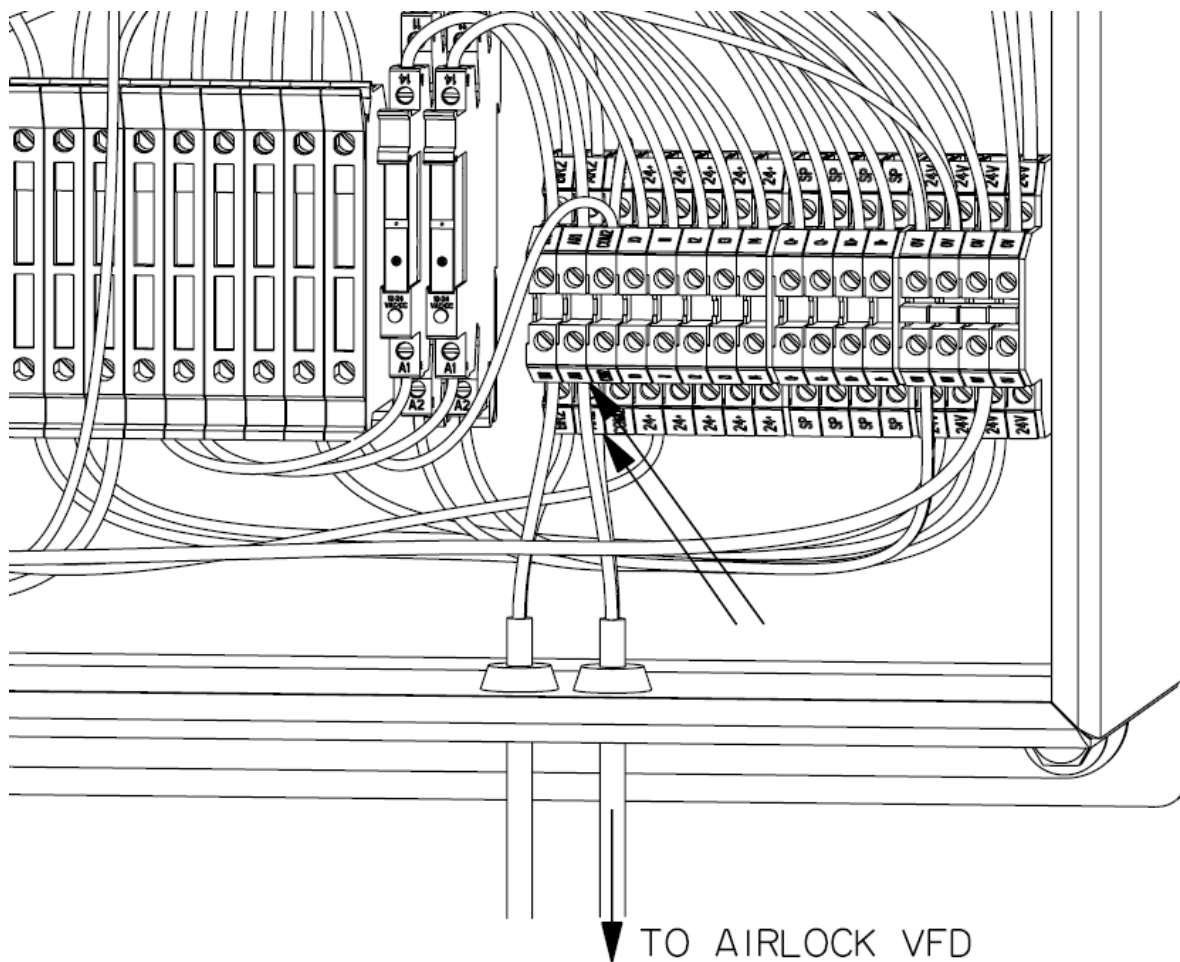

Figure 5-14: Airlock VFD run command terminal connections

- c. **Optional System Fault** (recommended to be used with **External Run**).
 - i. Connect **FUQ5** to an external automation system.
 - ii. Connect **COM2** to an external automation system.

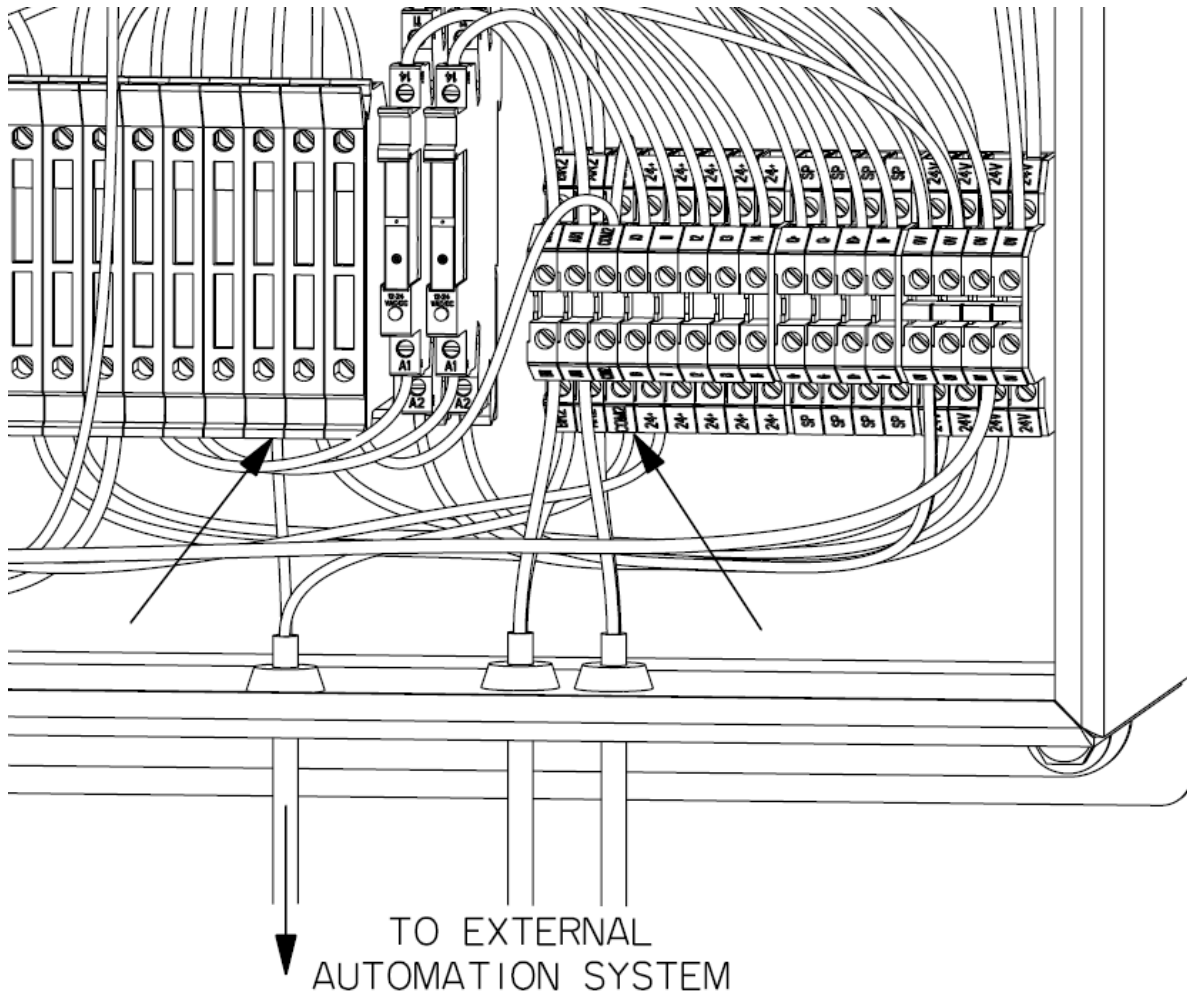

Figure 5-15: External automation system fault terminal connections

- d. **Optional Confirm Run** (recommended to be used with **External Run**).
- i. Connect **FUQ4** to an external automation system.
 - ii. Connect **COM2** to an external automation system.

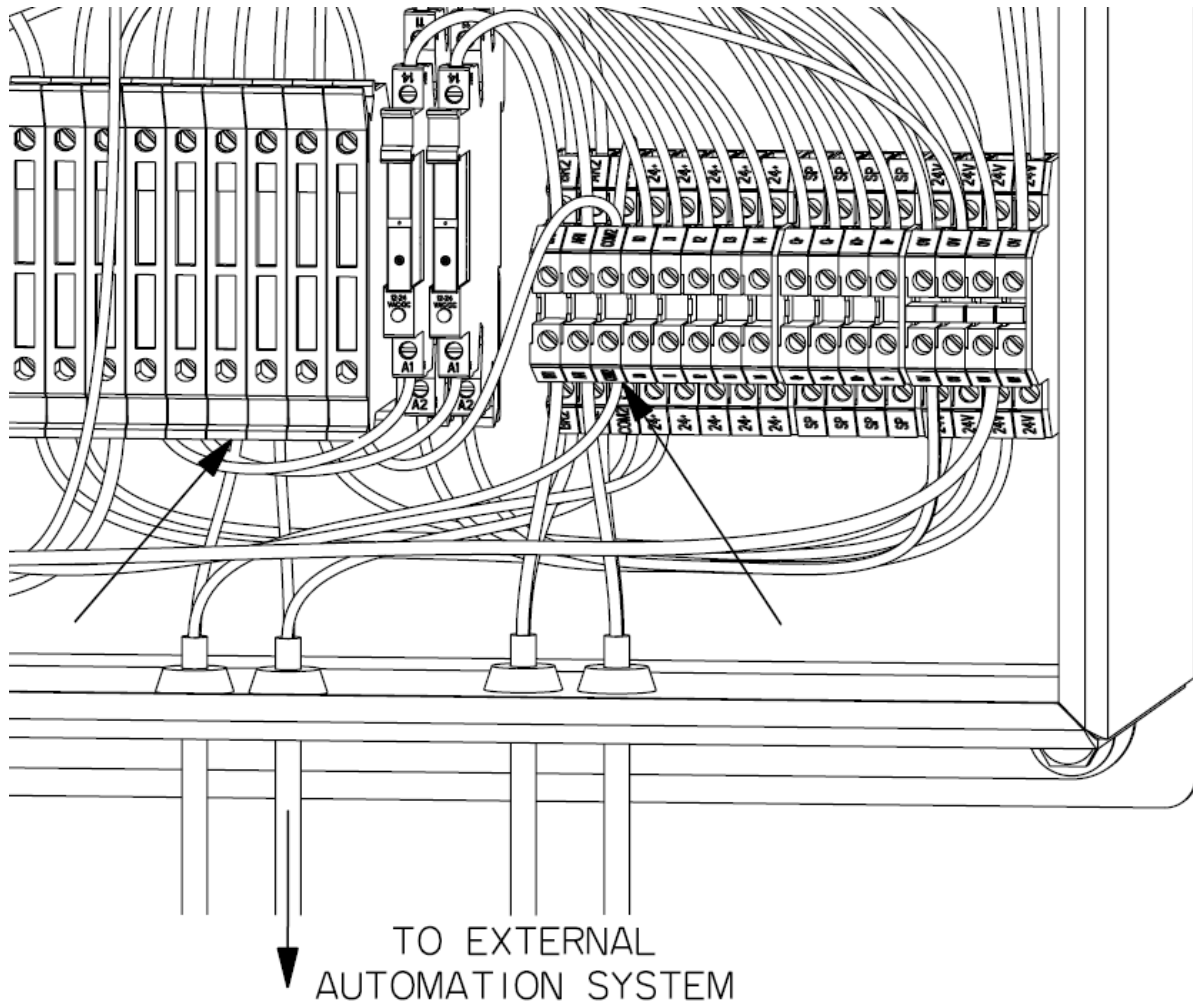

Figure 5-16: External automation system run confirmation terminal connections

8. Connect the Analog inputs as follows:

a. **Air Velocity Sensor**

- i. Connect **24V** to the positive terminal **R** of the signal conditioner.
- ii. Connect **I0+** to the negative terminal **P** of the signal conditioner.

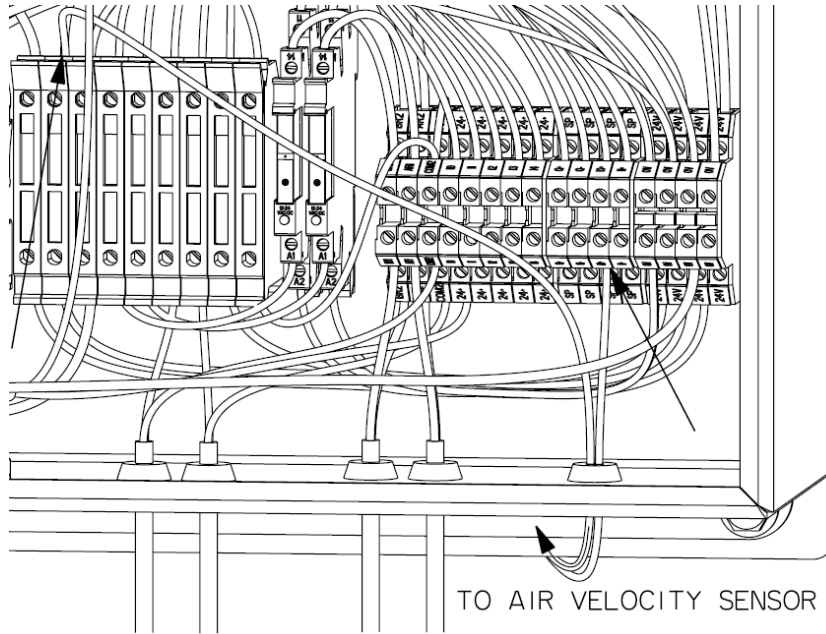

Figure 5-17: Signal conditioner terminal connections

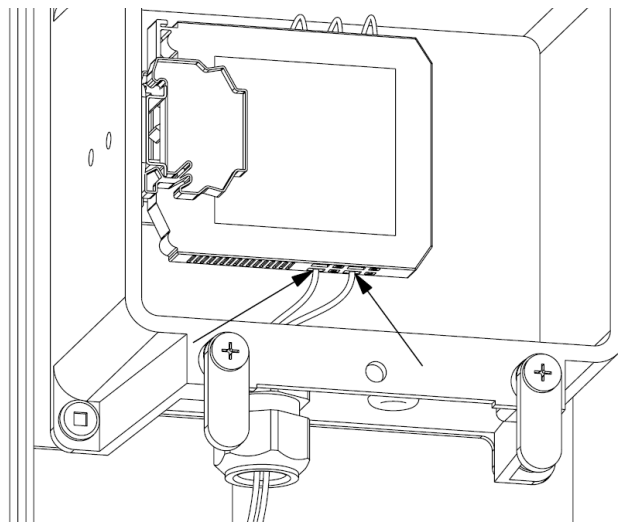

Figure 5-18: Signal conditioner connections

b. *Optional Pressure Sensor*

- i. Connect **24V** to the positive terminal of the pressure sensor.
- ii. Connect **I1+** to the output terminal of the pressure sensor.
- iii. Connect **0V** to the negative terminal of the pressure sensor.

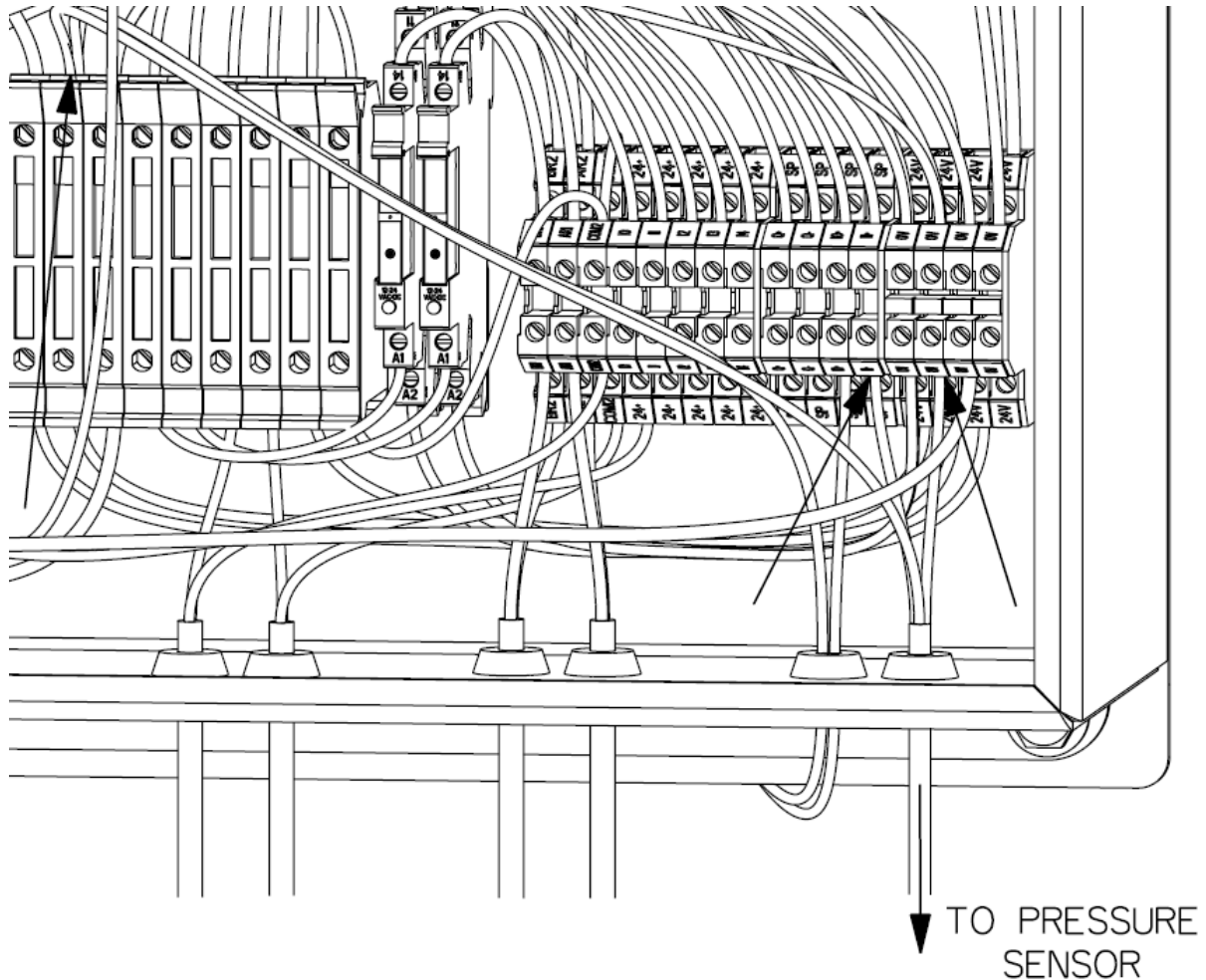

Figure 5-19: Pressure sensor terminal connections

9. Connect the Analog Control as follows:

a. **Blower VFD Speed Command**

- i. Prepare a two-wire cable (minimum 22 AWG, shielded wire preferred).
- ii. Connect **Q+** to the **Frequency** terminal on the blower VFD.
- iii. Connect **Q-** to the **Analog Common** terminal on the blower VFD.

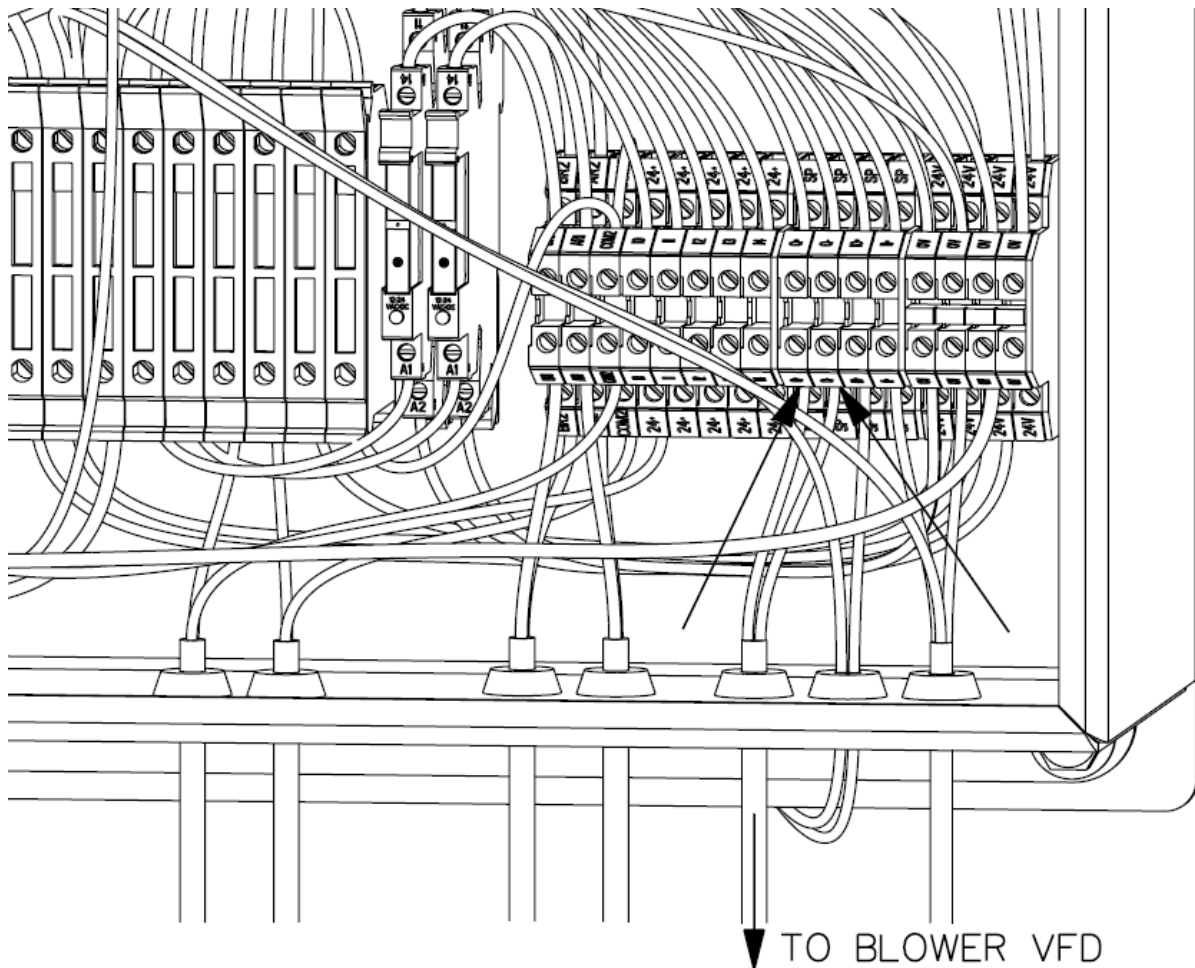

Figure 5-20: Blower VFD control terminal connections

- b. **Confirm Run** signal
- i. This connection must be a dry contact.
 - ii. Connect **+24** to the **NO Relay** terminal on the blower VFD.
 - iii. Connect **I2** to the **Common Relay** terminal on the blower VFD.

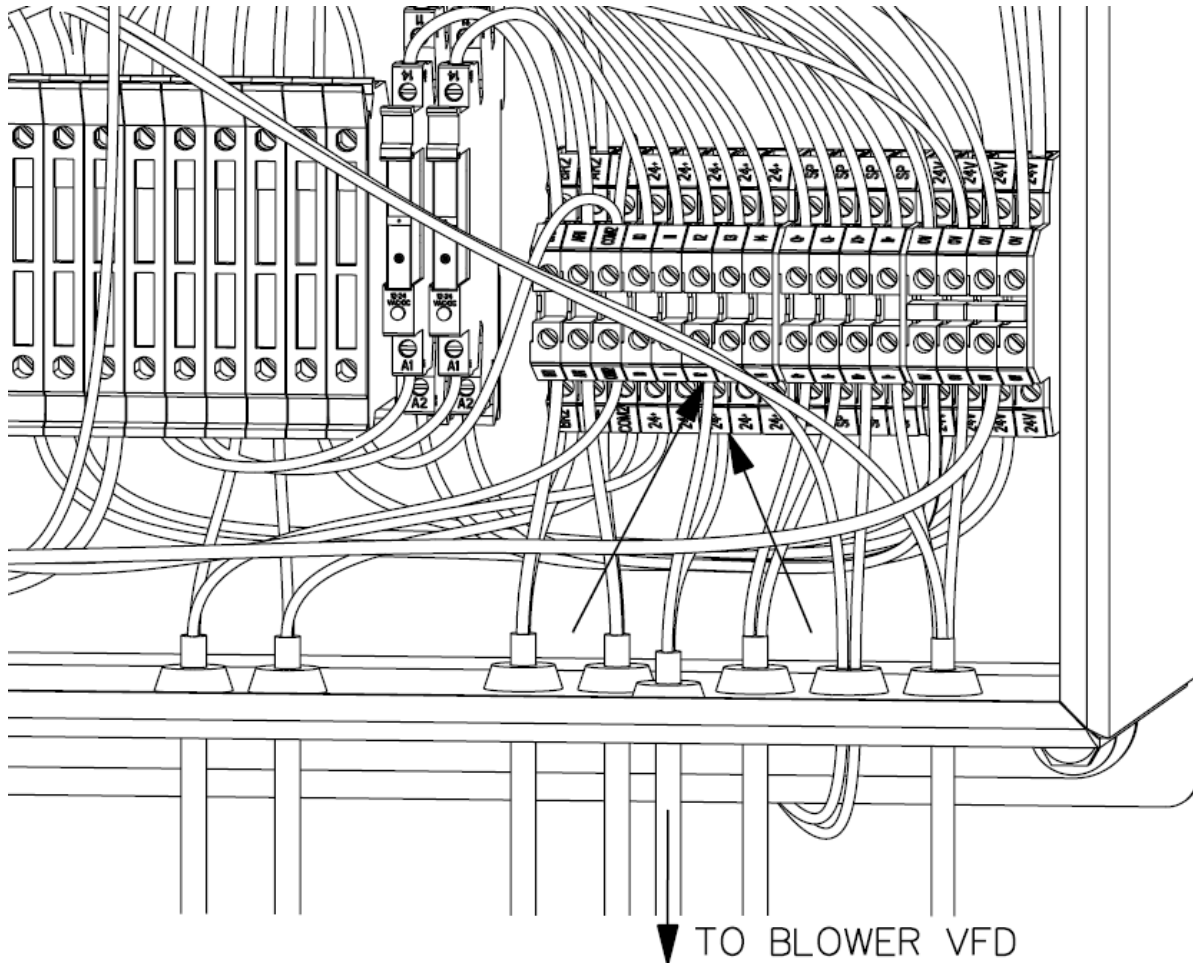

Figure 5-21: Confirm run signal terminal connections

- c. **System Fault** signal
 - i. This connection must be a dry contact.
 - ii. Connect **+24** to the **Low-Speed NO** terminal on the blower VFD.
 - iii. Connect **I3** to the **Low-Speed Common** terminal on the blower VFD.

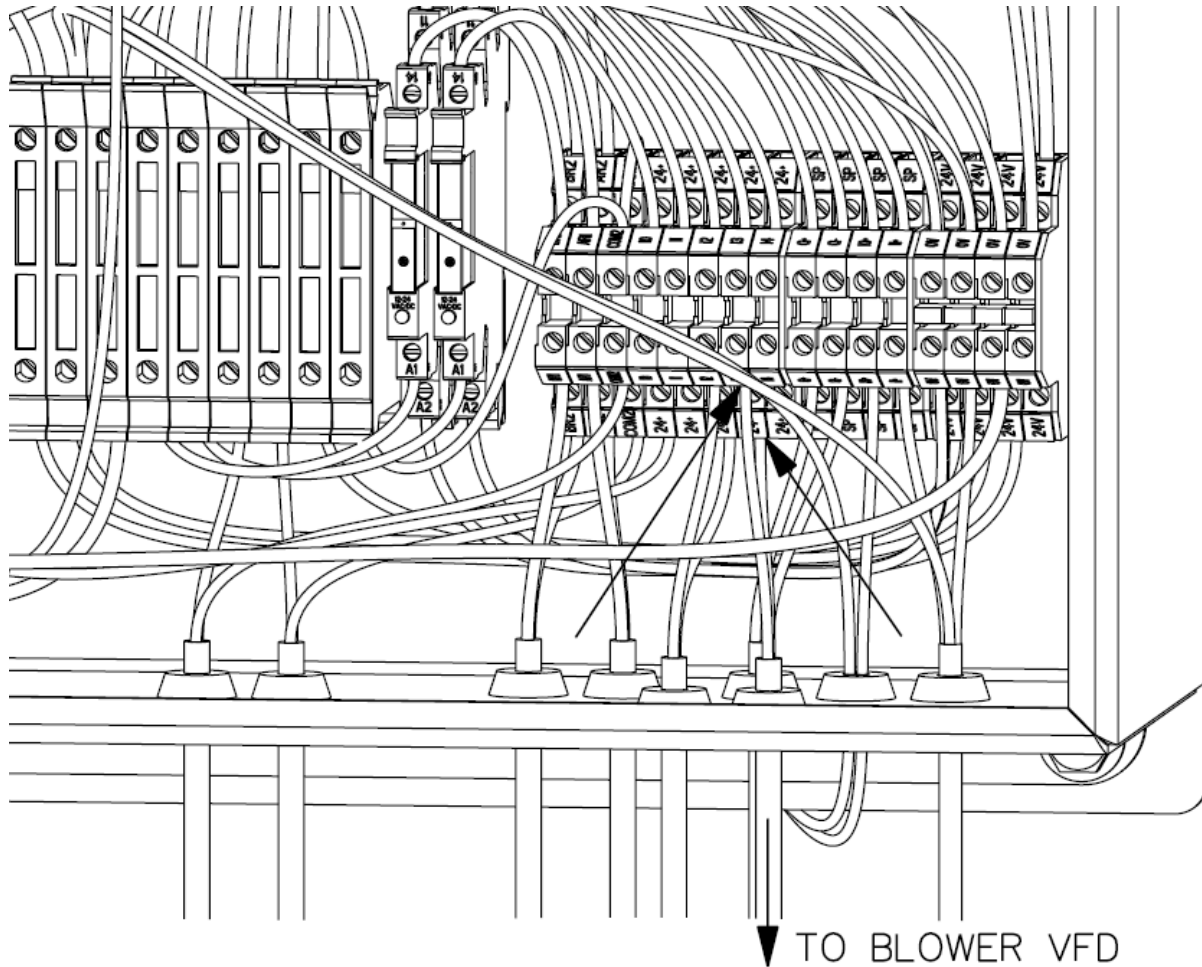

Figure 5-22: System fault signal terminal connections

10. Connect the PLC digital inputs as follows:

NOTE: Use a minimum of 22 AWG wire to connect digital inputs.

a. **Airlock Fault**

- i. This connection must be a dry contact.
- ii. For airlocks equipped with a VFD:
 - Connect **+24** to the **NO Relay** terminal on the airlock VFD.
 - Connect **I4** to the **Common Relay** terminal on the airlock VFD.
- iii. For airlocks equipped with an ATL starter:
 - Connect **+24** and **I4** to the **Normally Open** contact of the airlock motor overload.

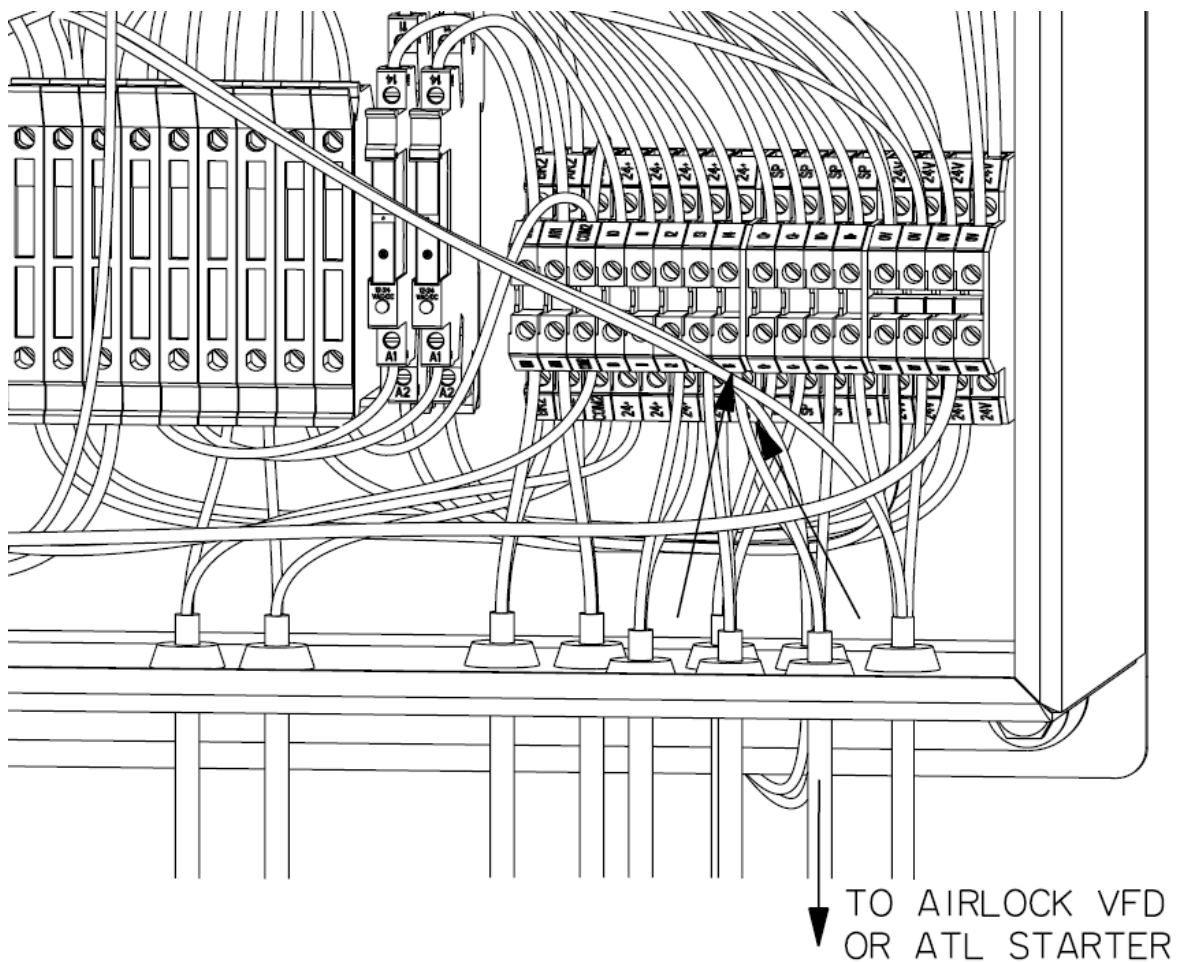

Figure 5-23: Airlock fault terminal connections

- b. *Optional Bin Full* sensor connection (will stop the Smart-Flo system when the sensor detects the full level of the bin).
 - i. This connection must be a dry contact.
 - ii. Connect **+24** to the digital level sensor from the bin.
 - iii. Connect **I0** to the digital level sensor from the bin.

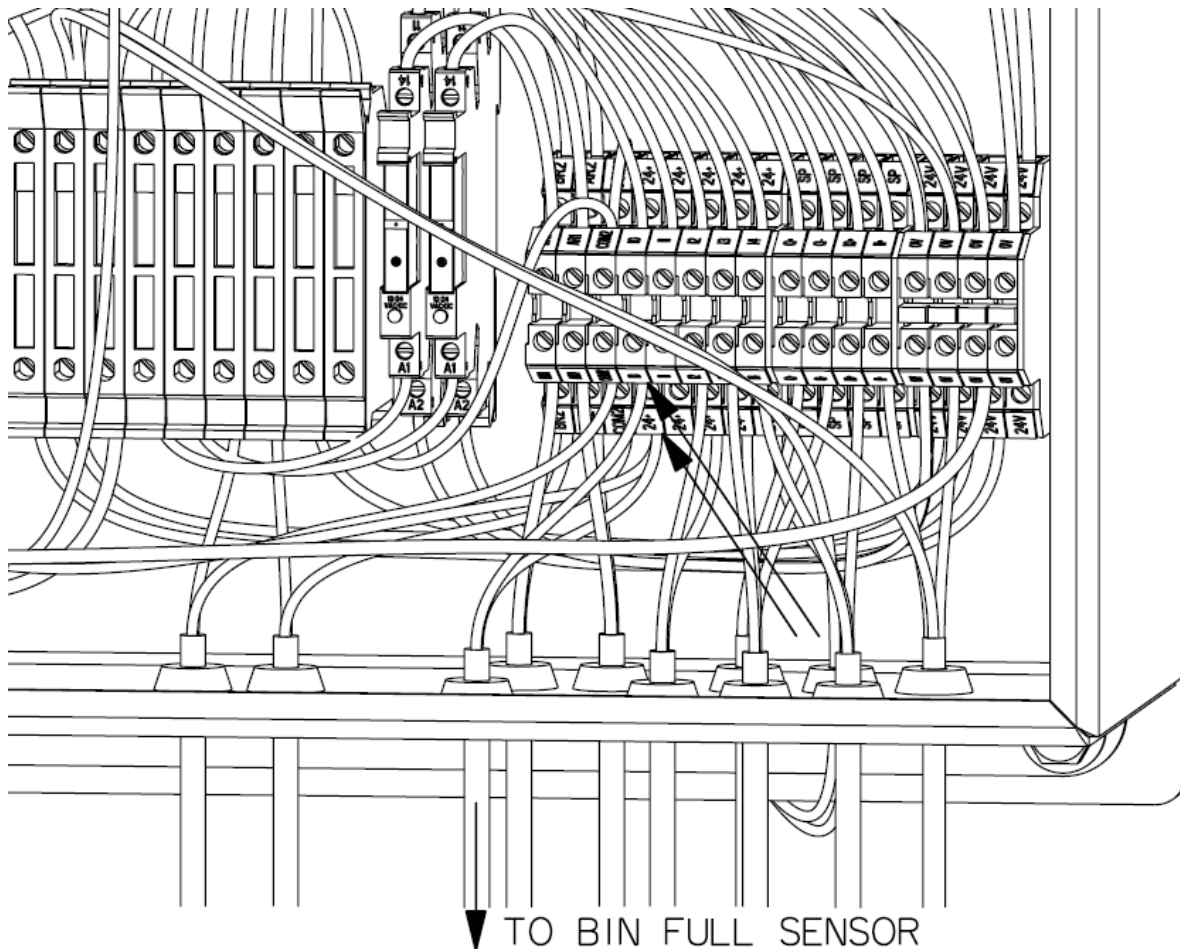

Figure 5-24: Bin full sensor terminal connections

- c. **Optional External Run** command (allows the Smart-Flo system to be started and stopped via an external signal, such as from a dryer).
- i. This connection must be a dry contact.
 - ii. Connect **+24** to the external start signal.
 - iii. Connect **I1** to the external start signal.

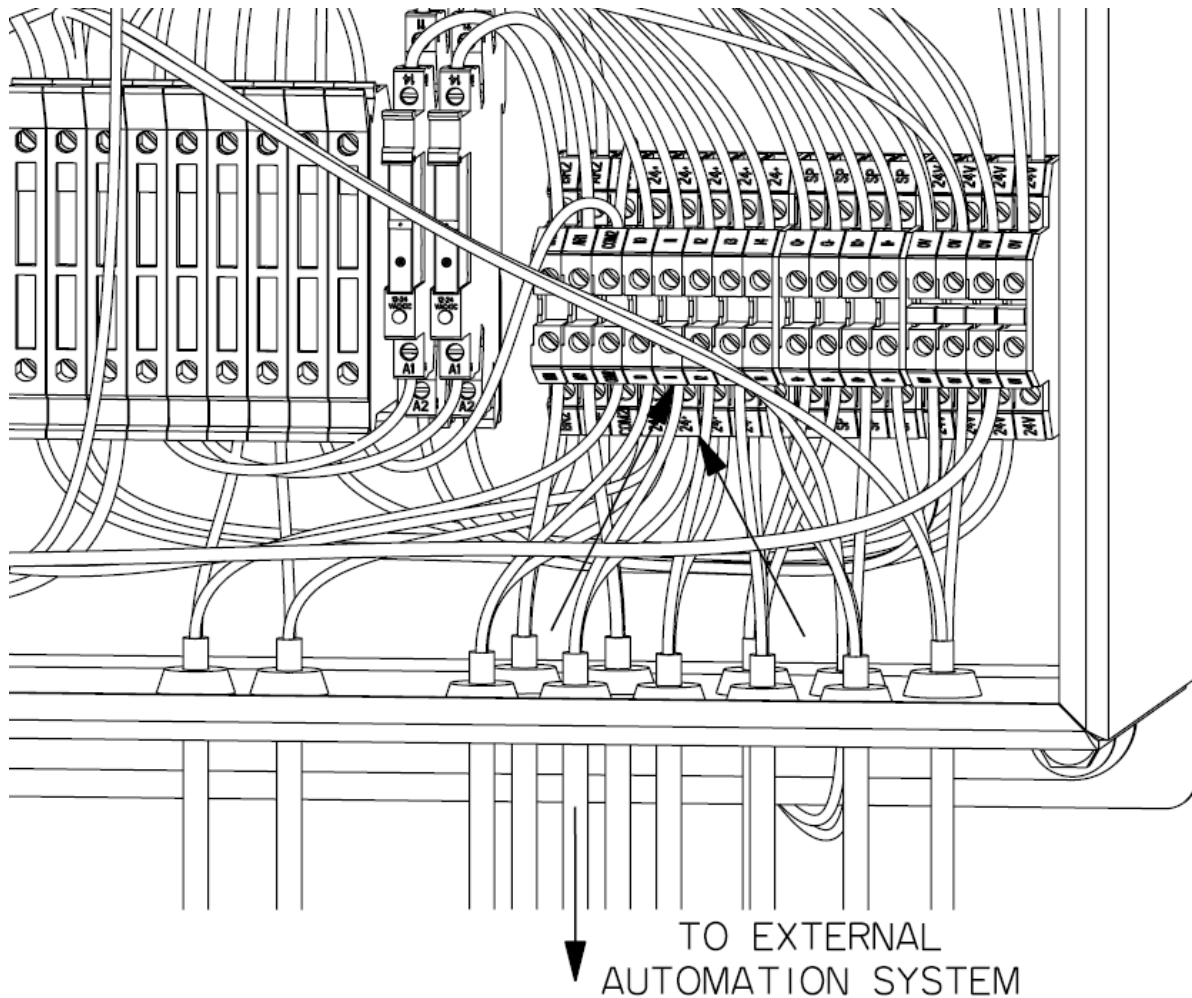

Figure 5-25: External run signal terminal connections

INITIAL SET-UP

Blower VFD Analog Communication

To set-up analog communication to the blower VFD, proceed as follows:

1. Clear the area of bystanders, especially small children.
2. Ensure the power sources for the control panel, blower, and airlock have not been locked-out. If locked-out, identify the cause and retrieve the tag before engaging power.
3. Engage the power to the Smart-Flo control panel.
4. Engage the power to the blower VFD.
5. Reset the blower VFD to the factory settings to prevent any additional potentially incorrect settings that may have been altered.
6. Identify the VFD model and proceed with the appropriate model's procedures below.

For the **Toshiba VF-S15** model, proceed as follows:

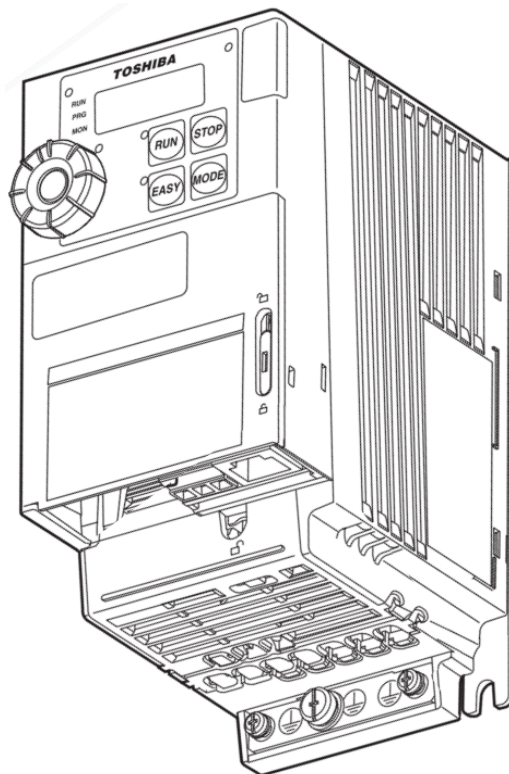

Figure 5-26: Toshiba VF-S15 VFD

1. Press the **MODE** key.
2. Scroll the wheel until **CMOD** is displayed on the screen, click the scroll wheel to select.
 - a. Set the value for **CMOD** to 0 and click the scroll wheel.
3. Scroll the wheel until **FMOD** is displayed on the screen, click the scroll wheel.
 - a. Set the value for **FMOD** to 8 and click the scroll wheel.
4. Scroll the wheel until **F1--** is displayed on the screen, click the scroll wheel.
 - a. Scroll until **F130** is displayed and click the scroll wheel.
 - i. Set the value to 10 and click the scroll wheel.
 - b. Scroll until **F132** is displayed and click the scroll wheel.
 - i. Set the value to 4 and click the scroll wheel.
 - b. Scroll until **F216** is displayed and click the scroll wheel.
 - i. Set the value to 20 and click the scroll wheel.
 - c. Scroll until **F217** is displayed and click the scroll wheel.
 - i. Set the value to 0.0 and click the scroll wheel.
 - d. Scroll until **F218** is displayed and click the scroll wheel.
 - i. Set the value to 100 and click the scroll wheel.
 - e. Scroll until **F219** is displayed and click the scroll wheel.
 - i. Set the value to 60.0 and click the scroll wheel.
 - f. Scroll until **F209** is displayed and click the scroll wheel.
 - i. Set the value to 64 and click the scroll wheel.
5. Scroll the wheel until **ACC** is displayed on the screen, click the scroll wheel.
 - a. Set the value for **ACC** to 13 and click the scroll wheel.
6. Scroll the wheel until **dEC** is displayed on the screen, click the scroll wheel.
 - a. Set the value for **dEC** to 13 and click the scroll wheel.
7. Scroll the wheel until **LL** is displayed on the screen, click the scroll wheel.
 - a. Set the value for **LL** to 20 and click the scroll wheel.
8. For single phase applications, calculate the percentage of the motor's full load amperage (FLA) to that of the VFD.
 - a. Scroll the wheel until **tHr** is displayed on the screen, click the scroll wheel.
 - i. Set the value to the calculated percentage and click the scroll wheel.
9. If the system utilizes a 3 phase motor or drive while using single phase power, disable phase detection.
 - a. Scroll the wheel until **F1--** is displayed on the screen, click the scroll wheel.
 - i. Scroll until **F608** is displayed and click the scroll wheel.
 - Set the value for **F608** to 0 and click the scroll wheel.

For the **Toshiba VF-AS1** model, proceed as follows:

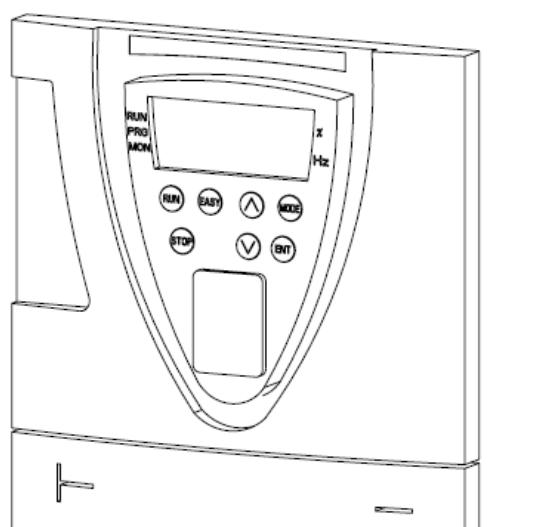

Figure 5-27: Toshiba VF-AS1 VFD

1. Press the **MODE** key.
2. Navigate using the arrow (\wedge) (\vee) keys until **CMOD** is displayed and press the **ENT** key.
 - a. Set the value for **CMOD** to 0 and press the **ENT** key.
3. Navigate until **FMOD** is displayed and press the **ENT** key.
 - a. Set the value for **FMOD** to 1 and press the **ENT** key.
4. Navigate until **F---** is displayed and press the **ENT** key.
 - a. Navigate until **F108** is displayed and press the **ENT** key.
 - i. Set the value for **F108** to 1 and press the **ENT** key.
 - b. Navigate until **F130** is displayed and press the **ENT** key.
 - i. Set the value for **F130** to 10 and press the **ENT** key.
 - c. Navigate until **F132** is displayed and press the **ENT** key.
 - i. Set the value for **F132** to 4 and press the **ENT** key.
 - d. Navigate until **F201** is displayed and press the **ENT** key.
 - i. Set the value for **F201** to 20 and press the **ENT** key.
5. Navigate until **ACC** is displayed and press the **ENT** key.
 - a. Set the value for **ACC** to 13 and press the **ENT** key.
6. Navigate until **dEC** is displayed and press the **ENT** key.
 - a. Set the value for **dEC** to 13 and press the **ENT** key.
7. Navigate until **LL** is displayed and press the **ENT** key.

- a. Set the value for **LL** to 20 and press the **ENT** key.
8. For single phase applications, calculate the percentage of the motor's full load amperage (FLA) to that of the VFD.
 - a. Navigate until **tHr** is displayed and press the **ENT** key.
 - i. Set the value for **tHr** to the calculated percentage and press the **ENT** key.
9. If the system utilizes a 3 phase motor or drive while using single phase power, disable phase detection.
 - a. Navigate until **F---** is displayed and press the **ENT** key.
 - i. Navigate until **F608** is displayed and press the **ENT** key.
 - Set the value for **F608** to 0 and press the **ENT** key.

For the **Toshiba VF-AS3** model, proceed as follows:

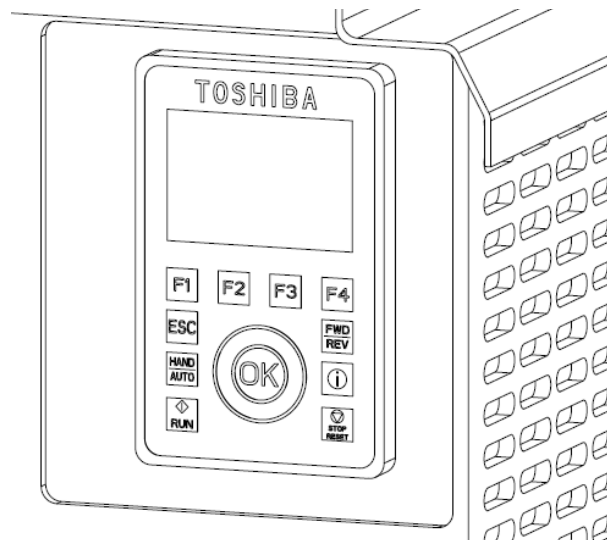

Figure 5-28: Toshiba VF-AS3 VFD

1. Press the **F3** key to switch to [Setting Mode]
2. Using the **F2** (↗) key, **F3** (↘) key and touch wheel, navigate to “4. Basic parameters” and press the **OK** key.
 - a. Navigate to “CMOd: Run command select” and press the **OK** key.
 - i. Navigate to “0: Terminal” and press the **OK** key.
 - b. Navigate to “FMOd: Run command select” and press the **OK** key.
 - i. Navigate to “3: Terminal II” and press the **OK** key.
 - c. Navigate to “ACC: Acceleration time 1” and press the **OK** key.
 - i. Set to 13 and press the **OK** key.

- d. Navigate to “dEC: Deceleration time 1” and press the **OK** key.
 - i. Set to 13 and press the **OK** key.
- e. Navigate to “LL: Lower limit frequency” and press the **OK** key.
 - i. Set to 20 and press the **OK** key.
3. Navigate to “5. Extended parameters” and press the **OK** key.
 - a. Navigate to “F130: Terminal FP function 1” and press the **OK** key.
 - i. Set to 10 and press the **OK** key.
 - b. Navigate to “F132: Terminal FL function” and press the **OK** key.
 - i. Set to 4 and press the **OK** key.
4. For single phase applications, identify the full load amperage (FLA) of the motor.
 - a. Navigate to “tHrA: Motor overload protection current 1” and press the **OK** key.
 - i. Set to the FLA of the motor and press the **OK** key.
5. If the system utilizes a 3 phase motor or drive while using single phase power, disable phase detection.
 - a. Press the **ESC** key to return the [Setting Mode] screen.
 - b. Navigate to “5. Extended parameters” and press the **OK** key.
 - i. Navigate to “F608: Input phase loss trip” and press the **OK** key.
 - Navigate to “0: Disabled” and press the **OK** key.

For the **ABB ACS580** model, proceed as follows:

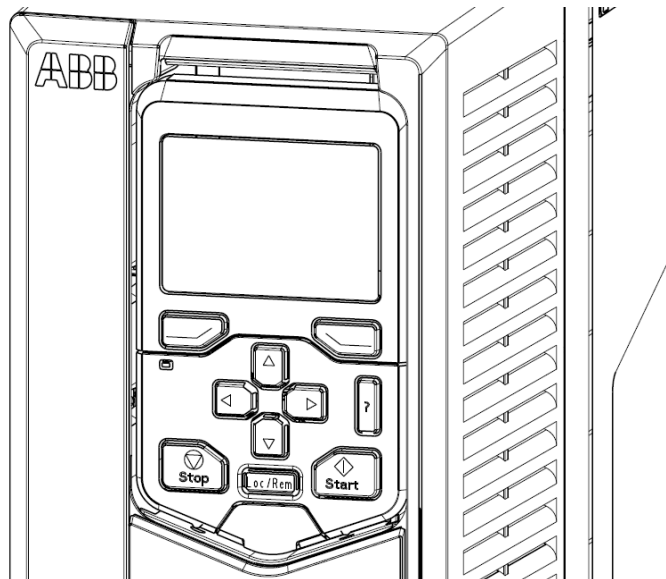

Figure 5-29: ABB ACS580 VFD

1. Press the **MENU** key.
2. Navigate using the arrow keys to **Primary Settings** and press the **SELECT** key.
 - a. Navigate to **Motor** and press the **SELECT** key.
 - i. Navigate to **Nominal Values** and press the **SELECT** key.
 - ii. Configure the values as required per the specific blower motor.
 - iii. Press the **BACK** key to return to the **Primary Settings**.
 - b. Navigate to **Macro** and press the **SELECT** key.
 - i. Navigate to **ABB Standard** and press the **SELECT** key.
 - ii. Press the **BACK** key to return to the **Primary Settings**.
 - c. Navigate to **Start, stop, reference** and press the **SELECT** key.
 - i. Navigate to **Reference from:** and press the **SELECT** key.
 - Navigate to **AI1 directly** and press the **SELECT** key.
 - ii. Navigate to **Start/stop/dir from:** and press the **SELECT** key.
 - Navigate to **DI1 start/stop** and press the **SELECT** key.
 - iii. Press the **BACK** key to return to the **Primary Settings**.
 - d. Navigate to **Ramps** and press the **SELECT** key.
 - i. Navigate to **Acceleration time** and press the **SELECT** key.
 - Set the value to 13 s and press the **SELECT** key.
 - ii. Navigate to **Deceleration time** and press the **SELECT** key.
 - Set the value to 13 s and press the **SELECT** key.
 - iii. Press the **BACK** key to return to the **Main menu**.
 - e. Navigate to **Limits** and press the **SELECT** key.
 - i. Navigate to **Minimum frequency** and press the **SELECT** key.
 - Set the value to 0 Hz and press the **SELECT** key.
 - ii. Navigate to **Maximum frequency** and press the **SELECT** key.
 - Set the value to 60 Hz and press the **SELECT** key.
 - iii. Press the **BACK** key to return to the **Main menu**.
3. Navigate to **I/O** and press the **SELECT** key.
 - a. Navigate to **DI1** and press the **SELECT** key.
 - b. Ensure the parameter is set up for **Start/stop**.
 - c. Press the **BACK** key to return to the **Main menu**.
4. Navigate to **Parameters** and press the **SELECT** key.

- a. Navigate to **Complete list** and press the **SELECT** key.
 - i. Navigate to **12.15 AI1 unit selection** and press the **SELECT** key.
 - o Set the parameter to **Milliamperes** and press the **SELECT** key.
 - ii. Navigate to **12.17 AI1 min** and press the **SELECT** key.
 - o Set the value to 4.00 mA and press the **SELECT** key.
 - iii. Navigate to **12.18 AI1 max** and press the **SELECT** key.
 - o Set the value to 20.00 mA and press the **SELECT** key.
 - iv. Navigate to **12.19 AI1 scaled at AI1 min** and press the **SELECT** key.
 - o Set the value to 0 Hz and press the **SELECT** key.
 - v. Navigate to **12.20 AI1 scaled at AI1 max** and press the **SELECT** key.
 - o Set the value to 60 Hz and press the **SELECT** key.
 - vi. Navigate to **20.01 Ext1 commands** and press the **SELECT** key.
 - o Set the parameter to **In1 Start** and press the **SELECT** key.
 - vii. Navigate to **20.21 Direction** and press the **SELECT** key.
 - o Set the parameter to **Forward** and press the **SELECT** key.
5. For single phase applications, identify the full load amperage (FLA) of the motor.
 - a. Navigate to **Primary Settings** and press the **SELECT** key.
 - i. Navigate to **Limits** and press the **SELECT** key.
 - o Navigate to **Maximum current** and press the **SELECT** key.
 - a. Set the value to the motor FLA and press the **SELECT** key.

Blower VFD Modbus Communication

To set-up Modbus communication to the blower VFD, proceed as follows:

1. Clear the area of bystanders, especially small children.
2. Ensure the power sources for the control panel, blower, and airlock have not been locked-out. If locked-out, identify the cause and retrieve the tag before engaging power.
3. Engage the power to the Smart-Flo control panel.
4. Engage the power to the blower VFD.
5. Reset the blower VFD to the factory settings to prevent any additional potentially incorrect settings that may have been altered.
6. Identify the VFD model and proceed with the appropriate model's procedures below.

For the **Toshiba VF-S15** model, proceed as follows:

(Reference **Figure 5-26**)

1. Press the **MODE** key.
2. Scroll the wheel until **CMOD** is displayed on the screen, click the scroll wheel to select.
 - a. Set the value for **CMOD** to 2 and click the scroll wheel.
3. Scroll the wheel until **FMOD** is displayed on the screen, click the scroll wheel.
 - a. Set the value for **FMOD** to 4 and click the scroll wheel.
4. Scroll the wheel until **F1--** is displayed on the screen, click the scroll wheel.
 - a. Scroll until **F800** is displayed and click the scroll wheel.
 - ii. Set the value to 4 and click the scroll wheel.
 - b. Scroll until **F801** is displayed and click the scroll wheel.
 - i. Set the value to 1 and click the scroll wheel.
 - c. Scroll until **F802** is displayed and click the scroll wheel.
 - i. Set the value to 1 and click the scroll wheel.
 - d. Scroll until **F829** is displayed and click the scroll wheel.
 - i. Set the value to 1 and click the scroll wheel.
5. Scroll the wheel until **ACC** is displayed on the screen, click the scroll wheel.
 - a. Set the value for **ACC** to 13 and click the scroll wheel.
6. Scroll the wheel until **dEC** is displayed on the screen, click the scroll wheel.
 - a. Set the value for **dEC** to 13 and click the scroll wheel.

7. For single phase applications, calculate the percentage of the motor's full load amperage (FLA) to that of the VFD.
 - a. Scroll the wheel until **tHr** is displayed on the screen, click the scroll wheel.
 - i. Set the value to the calculated percentage and click the scroll wheel.
8. If the system utilizes a 3 phase motor or drive while using single phase power, disable phase detection.
 - a. Scroll the wheel until **F1--** is displayed on the screen, click the scroll wheel.
 - i. Scroll until **F608** is displayed and click the scroll wheel.
 - Set the value for **F608** to 0 and click the scroll wheel.
9. Restart the VFD

For the **Toshiba VF-AS1** model, proceed as follows:

(Reference **Figure 5-27**)

1. Press the **MODE** key.
2. Navigate using the arrow (**^**) (**v**) keys until **CMOD** is displayed and press the **ENT** key.
 - a. Set the value for **CMOD** to 2 and press the **ENT** key.
3. Navigate until **FMOD** is displayed and press the **ENT** key.
 - a. Set the value for **FMOD** to 5 and press the **ENT** key.
4. Navigate until **F---** is displayed and press the **ENT** key.
 - a. Navigate until **F800** is displayed and press the **ENT** key.
 - i. Set the value for **F800** to 1 and press the **ENT** key.
 - b. Navigate until **F801** is displayed and press the **ENT** key.
 - i. Set the value for **F801** to 1 and press the **ENT** key.
 - c. Navigate until **F802** is displayed and press the **ENT** key.
 - i. Set the value for **F802** to 1 and press the **ENT** key.
 - d. Navigate until **F807** is displayed and press the **ENT** key.
 - i. Set the value for **F807** to 1 and press the **ENT** key.
5. Navigate until **ACC** is displayed and press the **ENT** key.
 - a. Set the value for **ACC** to 13 and press the **ENT** key.
6. Navigate until **dEC** is displayed and press the **ENT** key.
 - a. Set the value for **dEC** to 13 and press the **ENT** key.

7. For single phase applications, calculate the percentage of the motor's full load amperage (FLA) to that of the VFD.
 - a. Press the **MODE** key.
 - b. Navigate until **tHr** is displayed and press the **ENT** key.
 - i. Set the value for **tHr** to the calculated percentage and press the **ENT** key.
8. If the system utilizes a 3 phase motor or drive while using single phase power, disable phase detection.
 - a. Press the **MODE** key.
 - b. Navigate until **F---** is displayed and press the **ENT** key.
 - i. Navigate until **F608** is displayed and press the **ENT** key.
 - Set the value for **F608** to 0 and press the **ENT** key.
9. Restart the VFD.

For the **Toshiba VF-AS3** model, proceed as follows:

(Reference **Figure 5-28**)

1. Press the **F3** key to switch to [Setting Mode]
2. Using the **F2** (↗) key, **F3** (↘) key and touch wheel, navigate to "4. Basic parameters" and press the **OK** key.
 - a. Navigate to "CMOd: Run command select" and press the **OK** key.
 - i. Navigate to "4: RS485 communication (CN 2)" and press the **OK** key.
 - b. Navigate to "FMd: Run command select" and press the **OK** key.
 - i. Navigate to "22: RS485 communication (CN2)" and press the **OK** key.
 - c. Navigate to "ACC: Acceleration time 1" and press the **OK** key.
 - i. Set the value to 13 and press the **OK** key.
 - d. Navigate to "dEC: Deceleration time 1" and press the **OK** key.
 - i. Set the value to 13 and press the **OK** key.
3. Press the **ESC** key to return the [Setting Mode] screen.
4. Navigate to "5. Extended parameters" and press the **OK** key.
 - a. Navigate to "3.8 RS485 Com. Parameters" and press the **OK** key.
 - i. Navigate to "F802: Inverter number (RS485 common)" and press the **OK** key.
 - Set the value to 1 and press the **OK** key.
 - ii. Navigate to "F820: RS485 (2) baud rate" and press the **OK** key.
 - Navigate to "1: 19200 bps" and press the **OK** key.

- iii. Navigate to "F821: RS485 (2) parity" and press the **OK** key.
 - Navigate to "1: Even parity" and press the **OK** key.
- iv. Navigate to "F827: RS485 (2) protocol" and press the **OK** key.
 - Navigate to "1: MODBUS" and press the **OK** key.
- v. Navigate to "F829: RS485 (2) wiring type" and press the **OK** key.
 - Navigate to "0: 2-wire" and press the **OK** key.
5. For single phase applications, identify the full load amperage (FLA) of the motor.
 - a. Press the **F3** key to switch to [Setting Mode]
 - b. Navigate to "4. Basic parameters" and press the **OK** key.
 - i. Navigate to "tHrA: Motor overload protection current 1" and press the **OK** key.
 - Set the to FLA of the motor and press the **OK** key.
6. If the system utilizes a 3 phase motor or drive while using single phase power, disable phase detection.
 - a. Press the **F3** key to switch to [Setting Mode].
 - b. Navigate to "5. Extended parameters" and press the **OK** key.
 - i. Navigate to "F608: Input phase loss trip" and press the **OK** key.
 - Navigate to "0: Disabled" and press the **OK** key.
7. Restart the VFD.

For the **Schneider ATV320** model, proceed as follows:

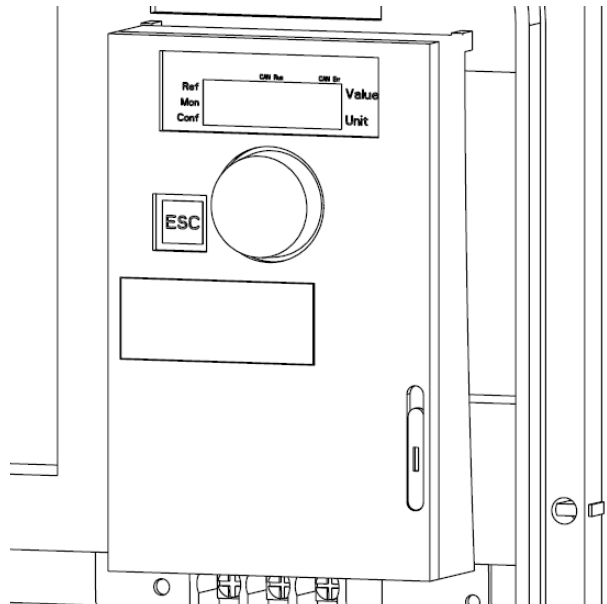

Figure 5-30: Schneider ATV320 VFD

1. Configure the drive for Modbus communication:
 - a. Press the dial.
 - b. Scroll the dial until **CO nF** is displayed and press the dial.
 - c. Scroll the dial until **FULL** is displayed and press the dial.
 - d. Scroll the dial until **CtL-** is displayed and press the dial.
 - e. Scroll the dial until **Fr1** is displayed and press the dial.
 - f. Scroll the dial until **Ndb** is displayed and press the dial.
 - g. Press **ESC** to return to **Fr1**.
 - h. Scroll the dial until **CHCF** is displayed and press the dial.
 - i. Scroll the dial until **IO** is displayed and press and hold the dial until the display returns to **CHCF**.
 - j. Scroll the dial until **Cd1** is displayed and press the dial.
 - k. Scroll the dial until **Ndb** is displayed and press the dial.
 - l. Press **ESC** to return to **Cd1**.
 - m. Scroll the dial until **Cd2** is displayed and press the dial.
 - n. Scroll the dial until **tEr** is displayed and press the dial.
 - o. Press **ESC** as required to return to **CtL-**.
 - p. Scroll the dial until **CoN-** is displayed and press the dial.
 - q. Scroll the dial until **Nd1-** is displayed and press the dial.
 - r. Scroll the dial until **Add** is displayed and press the dial.
 - s. Scroll the dial until the value reaches 1 and press the dial.
 - t. Press **ESC** as required until **rdy** is displayed.
2. Configure the read addresses from the VFD:
 - a. Press the dial.
 - b. Scroll the dial until **CO nF** is displayed and press the dial.
 - c. Scroll the dial until **FULL** is displayed and press the dial.
 - d. Scroll the dial until **CoN-** is displayed and press the dial.
 - e. Scroll the dial until **iCS-** is displayed and press the dial.
 - f. Scroll the dial until **nNA2** is displayed and press the dial.
 - g. Scroll the dial (in the reverse direction) until **0C82 (Output Frequency)** is displayed and press the dial.
 - h. Scroll the dial until **nNA3** is displayed and press the dial.
 - i. Scroll the dial until **0C8b (Motor Power)** is displayed and press the dial.

- j. Press **ESC** to return to **iCS-**.
 - k. Scroll the dial until **oCS-** is displayed and press the dial.
 - l. Scroll the dial until **nCA2** is displayed and press the dial.
 - m. Scroll the dial (in the reverse direction) until **2136** is displayed and press the dial. Ensure the display does **NOT** display **2136b**.
 - n. Press **ESC** as required until **rdy** is displayed.
3. Configure the VFD to fault and reset under the emergency stop button function.
 - a. Press the dial.
 - b. Scroll the dial until **CO nF** is displayed and press the dial.
 - c. Scroll the dial until **FULL** is displayed and press the dial.
 - d. Scroll the dial until **FLT** is displayed and press the dial.
 - e. Scroll the dial until **RSF** is displayed and press the dial.
 - f. Press the dial.
 - g. Scroll the dial until **Cd07** is displayed and press the dial.
 - h. Press **ESC** as required until **rdy** is displayed.
4. Configure the required VFD settings.
 - a. Press the dial.
 - b. Scroll the dial until **SEt-** is displayed and press the dial.
 - c. Scroll the dial until **ACC** is displayed and press the dial.
 - i. Set the value to 13 and press the dial.
 - d. Scroll the dial until **dEC** is displayed and press the dial.
 - i. Set the value to 13 and press the dial.
5. For single phase applications, identify the full load amperage (FLA) of the motor.
 - a. Press the dial.
 - b. Scroll the dial until **SEt-** is displayed and press the dial.
 - c. Scroll the dial until **ItH** is displayed and press the dial.
 - i. Set the value to the motor FLA and press the dial.
6. Upon completion of all configuration settings, cycle power to the drive.
7. Select the **SW1** switch.

For the **Delta C2000** model, proceed as follows:

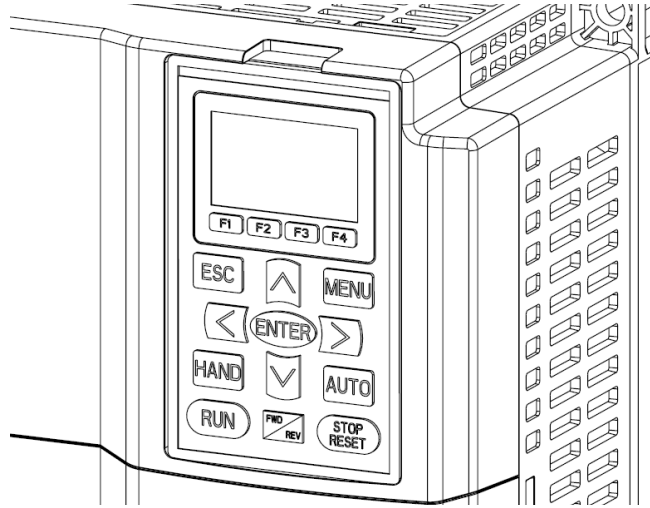

Figure 5-31: Delta C2000 VFD

1. Press the **MENU** key.
2. Use the arrow (∧) (∨) keys to navigate to “1: Pr Setup” and press the **ENTER** key.
 - a. Navigate to “00: System Parameter” and press the **ENTER** key.
 - i. Navigate to “20: Master Frequency Command” and press the **ENTER** key.
 - Navigate to “1: RS-485 communication” and press the **ENTER** key.
 - ii. Navigate to “21: Operation command” and press the **ENTER** key.
 - Navigate to “2: RS-485 communication” and press the **ENTER** key.
3. Press the **ESC** key to return to the “1: Pr Setup” menu.
 - a. Navigate to “01: Basic Parameters” and press the **ENTER** key.
 - i. Navigate to “12: Acceleration time 1” and press the **ENTER** key.
 - Scroll to set the value to 13 s and press the **ENTER** key.
 - ii. Navigate to “13: Deceleration time 1” and press the **ENTER** key.
 - Scroll to set the value to 13 s and press the **ENTER** key.
4. Press the **ESC** key to return to the “1: Pr Setup” menu.
 - a. Navigate to “09: Communication Parameters” and press the **ENTER** key.
 - i. Navigate to “00: Communication address” and press the **ENTER** key.
 - Scroll to set the value to 1 and press the **ENTER** key.
 - ii. Navigate to “01: COM1 transmission speed” and press the **ENTER** key.
 - Scroll to set the value to 19.2 Kbps and press the **ENTER** key.

- iii. Navigate to "04: COM1 communication protocol" and press the **ENTER** key
 - Scroll to "14: 8, E, 1 (RTU)" and press the **ENTER** key.
- iv. Navigate to "31: Internal communication protocol" and press the **ENTER** key.
 - Scroll to "0: MODBUS 485" and press the **ENTER** key.
5. For single phase applications, calculate the percentage of the full load amperage (FLA) of the motor to that of the VFD.
 - a. Navigate to "06: Protection Parameters" and press the **ENTER** key.
 - i. Navigate to "12: Current limit" and press the **ENTER** key.
 - Scroll to set the value to the calculated percentage and press the **ENTER** key.
6. Press the **ESC** key as required to return to Monitor Mode.
7. Upon completion of all configuration settings, cycle power to the drive.

For the **TECO-Westinghouse A510** model, proceed as follows:

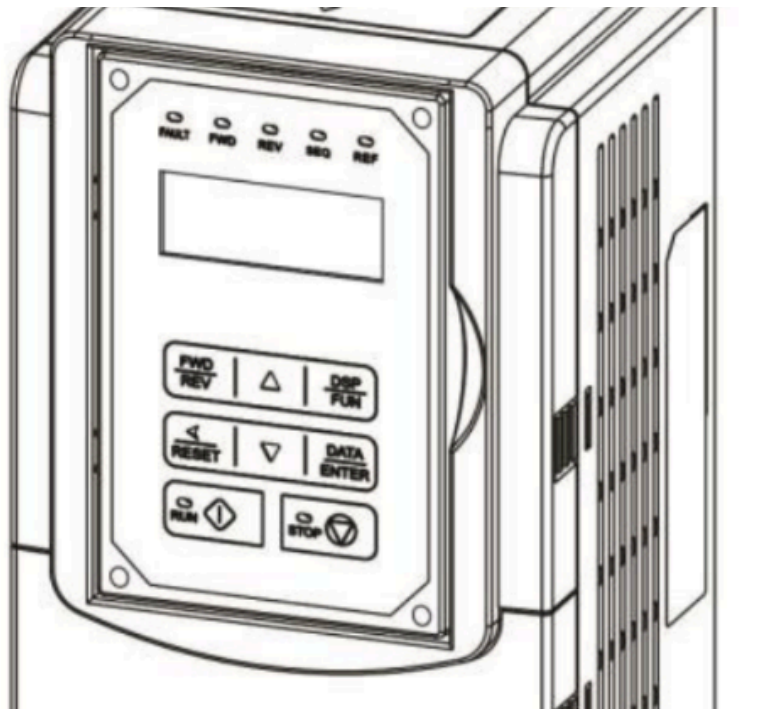

Figure 5-32: TECO-Westinghouse A510

1. Press the **DSP/FUN** key.
2. Use the arrow (**▲**)(**▼**) keys to navigate to “00 Basic Function” and press the **READ/ENTER** key.
 - a. Navigate to “02 Main Run Command Source Selection” and press the **READ/ENTER** key.
 - i. Navigate to “2: Communication Control (RS-485)” and press the **READ/ENTER** key.
 - b. Navigate to “05 Main Frequency Command Source Selection” and press the **READ/ENTER** key.
 - i. Navigate to “3: Communication Control (RS-485)” and press the **READ/ENTER** key.
 - c. Navigate to “14 Acceleration Time 1” and press the **READ/ENTER** key.
 - i. Set the value to 13 s and press the **READ/ENTER** key.
 - d. Navigate to “15 Deceleration Time 1” and press the **READ/ENTER** key.
 - i. Set the value to 13 s and press the **READ/ENTER** key.
3. Press the **◀/RESET** key to return to Parameter Group menu.
4. Navigate to “09 Communication Parameters” and press the **READ/ENTER** key.
 - a. Navigate to “00 INV Communication Station Address” and press the **READ/ENTER** key.
 - i. Set the value to 1 and press the **READ/ENTER** key.
 - b. Navigate to “01 Communication Mode Select” and press the **READ/ENTER** key.
 - i. Navigate to “0: MODBUS” and press the **READ/ENTER** key.
 - c. Navigate to “02 Baud Rate Setting (bps)” and press the **READ/ENTER** key.
 - i. Navigate to “4: 19200” and press the **READ/ENTER** key.
 - d. Navigate to “03 Stop Bit Selection” and press the **READ/ENTER** key.
 - i. Navigate to “0: 1 Stop Bit” and press the **READ/ENTER** key.
 - e. Navigate to “04 Parity Selection” and press the **READ/ENTER** key.
 - i. Navigate to “1: Even Bit” and press the **READ/ENTER** key.
 - f. Navigate to “05 Communication Data Bit Selection” and press the **READ/ENTER** key.
 - i. Navigate to “0: 8 Bit Data” and press the **READ/ENTER** key.
5. For single phase applications, identify the full load amperage (FLA) of the motor.
 - a. Navigate to “02 Motor Parameters” and press the **READ/ENTER** key.
 - i. Navigate to “02 Rated Current of Motor” and press the **READ/ENTER** key.
 1. Set the value to the motor FLA and press the **READ/ENTER** key.
6. Press the **◀/RESET** key as required to return to Monitor Mode.
7. Upon completion of all configuration settings, cycle power to the drive.

For the **ABB ACS580** model, proceed as follows:

(Reference **Figure 5-29**)

1. Press the **MENU** key.
2. Navigate using the arrow keys to **Primary Settings** and press the **SELECT** key.
 - a. Navigate to **Motor** and press the **SELECT** key.
 - i. Navigate to **Nominal Values** and press the **SELECT** key.
 - ii. Configure the values as required per the specific blower motor.
 - iii. Press the **BACK** key to return to the **Primary Settings**.
 - b. Navigate to **Macro** and press the **SELECT** key.
 - i. Navigate to **ABB Standard** and press the **SELECT** key.
 - ii. Press the **BACK** key to return to the **Primary Settings**.
 - c. Navigate to **Start, stop, reference** and press the **SELECT** key.
 - i. Navigate to **Reference from:** and press the **SELECT** key.
 - Navigate to **EFB ref1** and press the **SELECT** key.
 - ii. Navigate to **Start/stop/dir from:** and press the **SELECT** key.
 - Navigate to **Embedded fieldbus** and press the **SELECT** key.
 - iii. Press the **BACK** key to return to the **Primary Settings**.
 - d. Navigate to **Ramps** and press the **SELECT** key.
 - i. Navigate to **Acceleration time** and press the **SELECT** key.
 - Set the value to 13 s and press the **SELECT** key.
 - ii. Navigate to **Deceleration time** and press the **SELECT** key.
 - Set the value to 13 s and press the **SELECT** key.
 - iii. Press the **BACK** key to return to the **Main menu**.
 - e. Navigate to **Limits** and press the **SELECT** key.
 - i. Navigate to **Minimum frequency** and press the **SELECT** key.
 - Set the value to 0 Hz and press the **SELECT** key.
 - ii. Navigate to **Maximum frequency** and press the **SELECT** key.
 - Set the value to 60 Hz and press the **SELECT** key.
 - iii. Press the **BACK** key to return to the **Main menu**.
3. Navigate to **Parameters** and press the **SELECT** key.
 - a. Navigate to **Complete list** and press the **SELECT** key.
 - i. Navigate to **20.01 Ext1 commands** and press the **SELECT** key.
 - Set the parameter to **Embedded fieldbus** and press the **SELECT** key.

- ii. Navigate to **20.21 Direction** and press the **SELECT** key.
 - o Set the parameter to **Forward** and press the **SELECT** key.
 - iii. Navigate to **58.01 Protocol enable** and press the **SELECT** key.
 - o Set the parameter to **Modbus RTU** and press the **SELECT** key.
 - iv. Navigate to **58.03 Node address** and press the **SELECT** key.
 - o Set the value to 1 and press the **SELECT** key.
 - v. Navigate to **58.04 Baud rate** and press the **SELECT** key.
 - o Set the parameter to **19.2 kbps** and press the **SELECT** key.
 - vi. Navigate to **58.05 Parity** and press the **SELECT** key.
 - o Set the parameter to **8 EVEN 1** and press the **SELECT** key.
 - vii. Navigate to **58.26 EFB ref1 type** and press the **SELECT** key.
 - o Set the parameter to **Frequency** and press the **SELECT** key.
 - viii. Navigate to **58.101 Data I/O 1** and press the **SELECT** key.
 - o Set the parameter to **CW 16bit** and press the **SELECT** key.
 - ix. Navigate to **58.102 Data I/O 2** and press the **SELECT** key.
 - o Set the parameter to **Ref1 16bit** and press the **SELECT** key.
 - x. Navigate to **58.103 Data I/O 3** and press the **SELECT** key.
 - o Navigate to **Other** and press the **SELECT** key.
 - o Navigate to **Actual values** and press the **SELECT** key.
 - o Set the parameter to **Output Frequency** and press the **SELECT** key.
 - xi. Navigate to **58.104 Data I/O 4** and press the **SELECT** key.
 - o Navigate to **Other** and press the **SELECT** key.
 - o Navigate to **Actual values** and press the **SELECT** key.
 - o Set the parameter to **Output Load** and press the **SELECT** key.
 - xii. Navigate to **58.106 Data I/O 6** and press the **SELECT** key.
 - o Set the parameter to **SW 16bit** and press the **SELECT** key.
4. For single phase applications, identify the full load amperage (FLA) of the motor.
 - a. Navigate to **Primary Settings** and press the **SELECT** key.
 - i. Navigate to **Limits** and press the **SELECT** key.
 - o Navigate to **Maximum current** and press the **SELECT** key.
 - a. Set the value to the motor FLA and press the **SELECT** key.
5. Cycle the power to the VFD.

Control Panel HMI Configuration

To configure the HMI screen of the control panel, proceed as follows:

1. Clear the area of bystanders, especially small children.
2. Ensure the power sources for the control panel, blower, and airlock have not been locked-out. If locked-out, identify the cause and retrieve the tag before engaging power.
3. Engage the power to the Smart-Flo control panel.
4. Once powered on, press the “Press to Reset” button shown on the display.
5. Following the system restart, the display will appear as seen in **Figure 5-33**.



Figure 5-33: HMI start-up screen

6. Press the arrow in the top right corner of the display to proceed to the Settings screen.

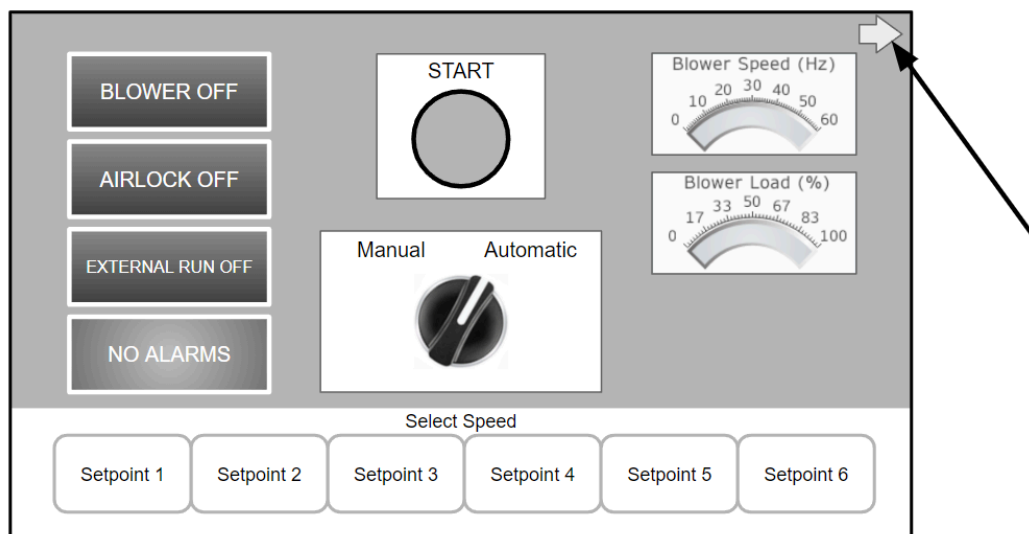

Figure 5-34: Home screen access to Settings screen

7. Press the “Advanced Settings” button at the bottom of the display.

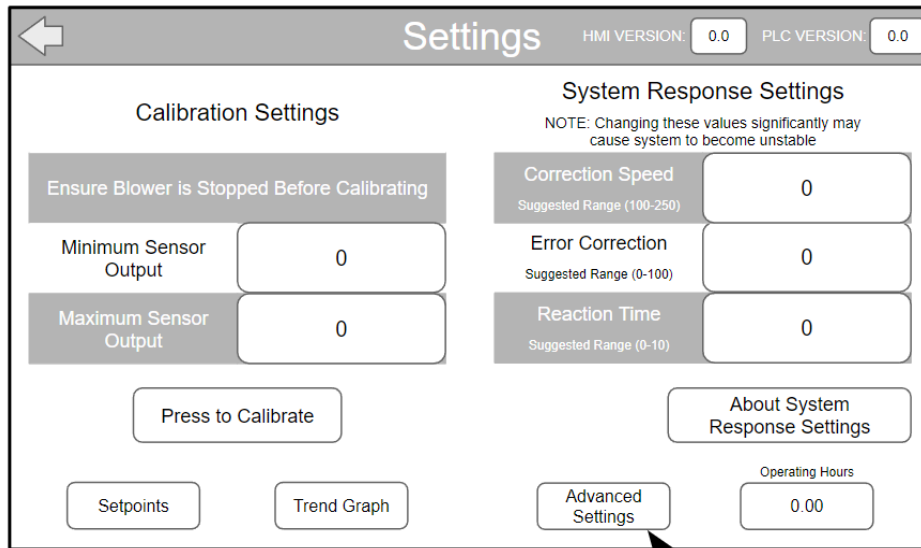

Figure 5-35: Advanced settings access

- Press and hold the “Factory Reset” button at the top of the display to ensure there are no parameters that have been configured with unintentional values. The value for each parameter should appear as seen in **Figure 5-36** after the reset.

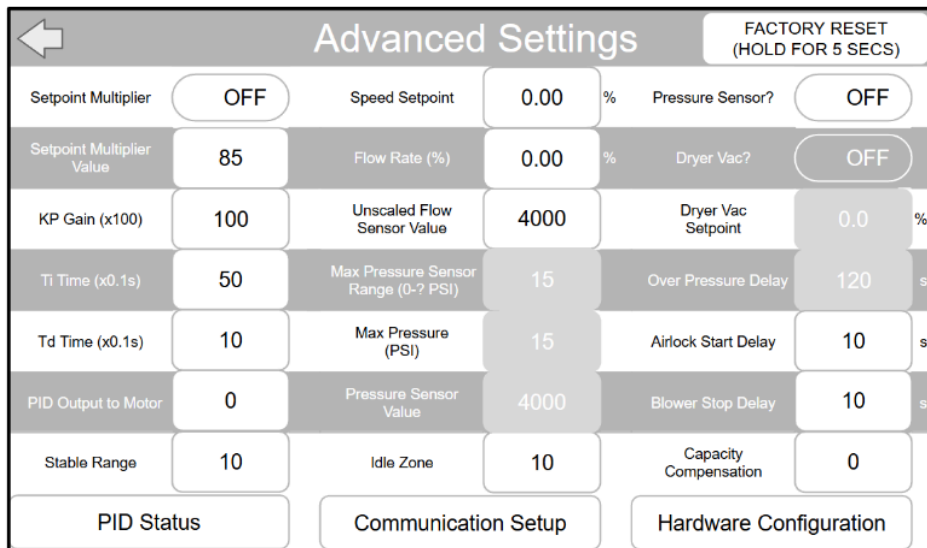

Figure 5-36: Factory reset values

9. Press the “Communication Setup” button at the bottom of the display.

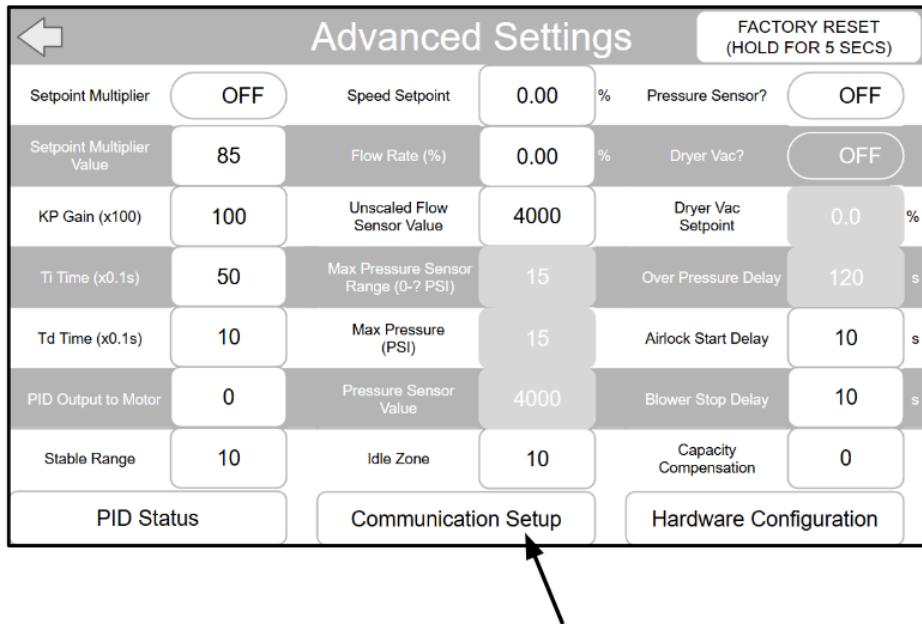

Figure 5-37: Communication configuration access

10. Use the first drop-down menu to select the type of communication used between the control panel and blower VFD. The default communication type is Analog.

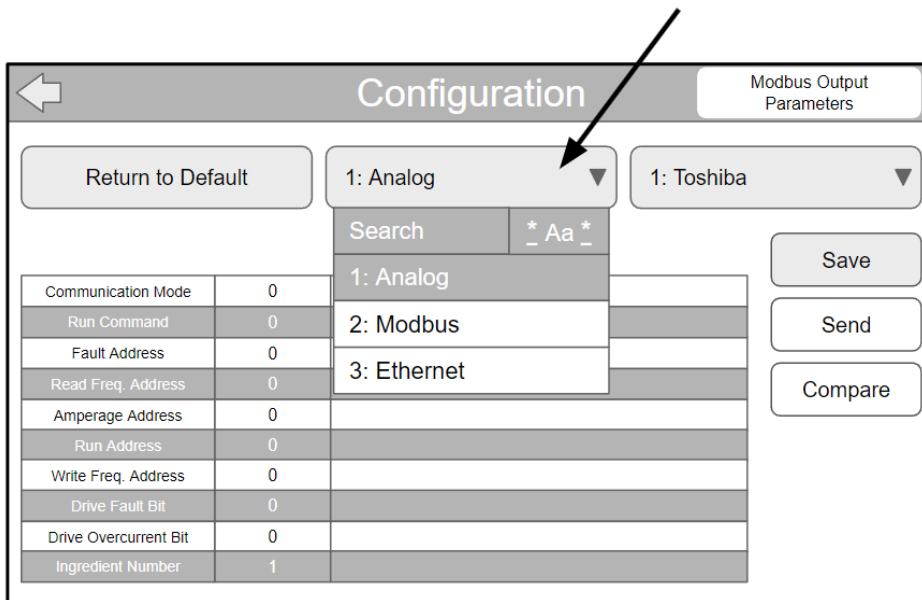

Figure 5-38: Communication type drop-down menu

11. Use the second drop-down menu to select the model of the blower VFD.

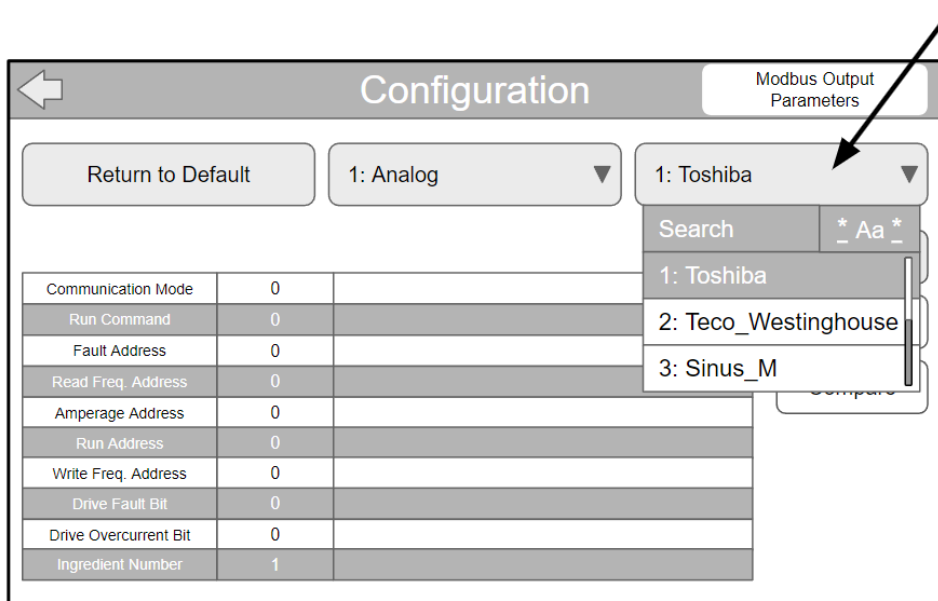

Figure 5-39: Blower VFD model drop-down menu

12. Press the “Send” button on the right side of the display to set the communication parameters.

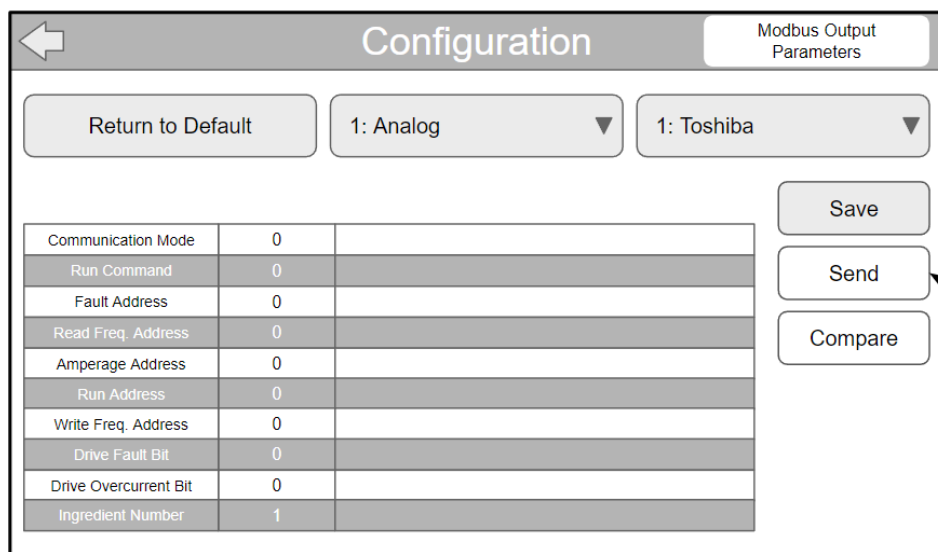

Figure 5-40: Setting of communication parameters

13. Press the “Compare” button to confirm the correct values have been sent to the PLC. Both columns will turn green when the display values match the values of the PLC.

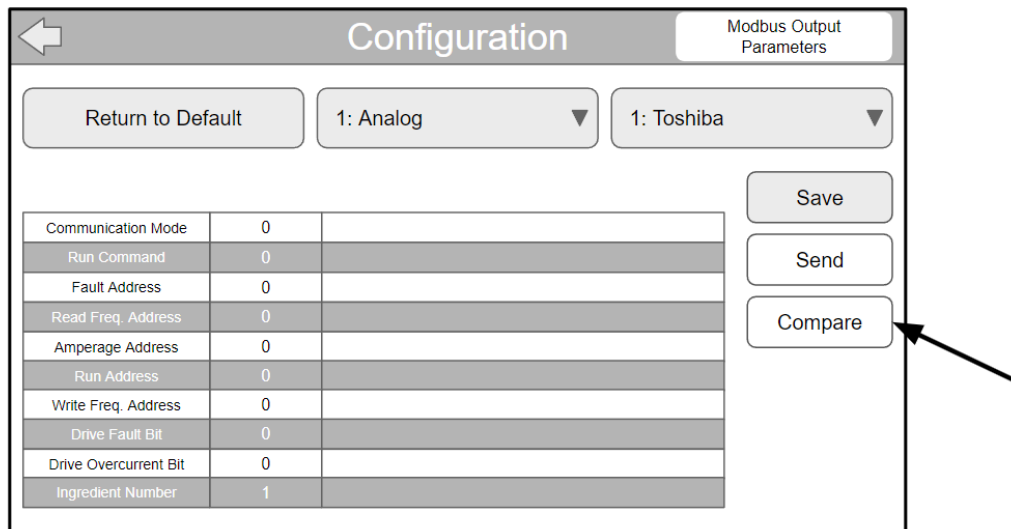

Figure 5-41: Comparison of communication parameters between HMI and PLC

14. Press the “Save” button to save the configured communication parameters.

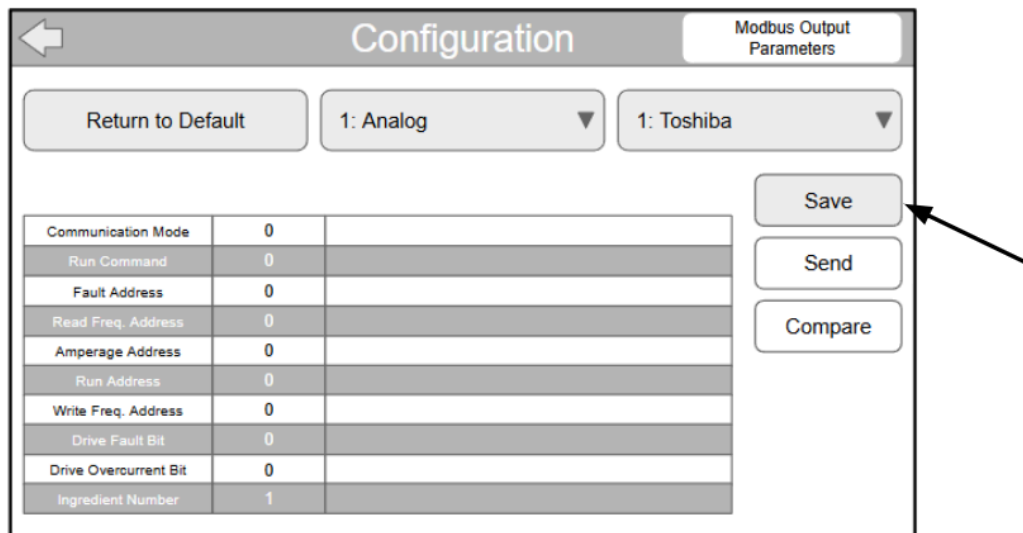

Figure 5-42: Saving of communication parameters

- Press the arrow in the top left corner of the display to return to the Advanced Settings screen.

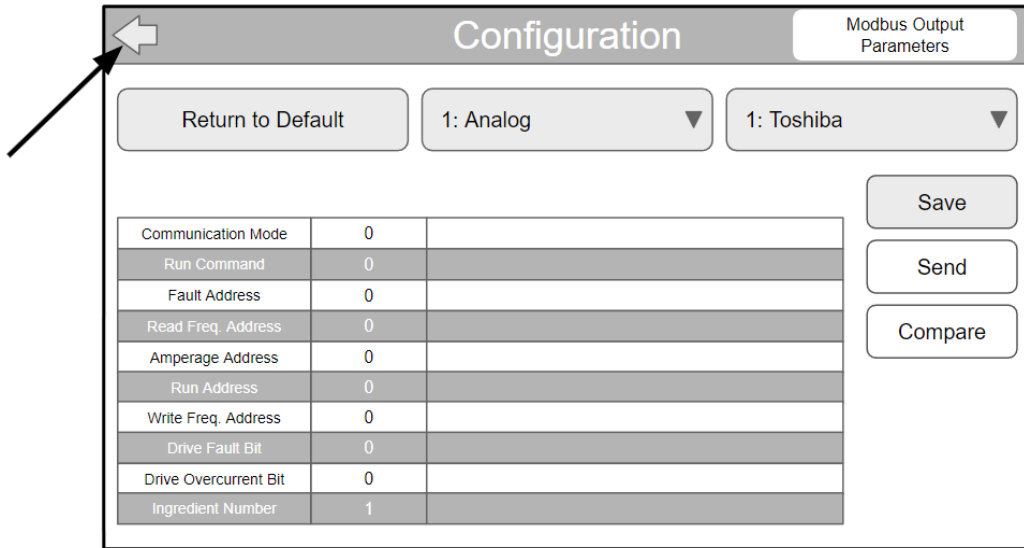

Figure 5-43: Return to Advanced Settings screen

- Confirm that the air velocity sensor is connected with reference to the "Unscaled Flow Sensor Value". By hand, rotate the counterweight and watch the "Unscaled Flow Sensor Value", if the value is equal to or greater than 4000, the sensor is properly connected.

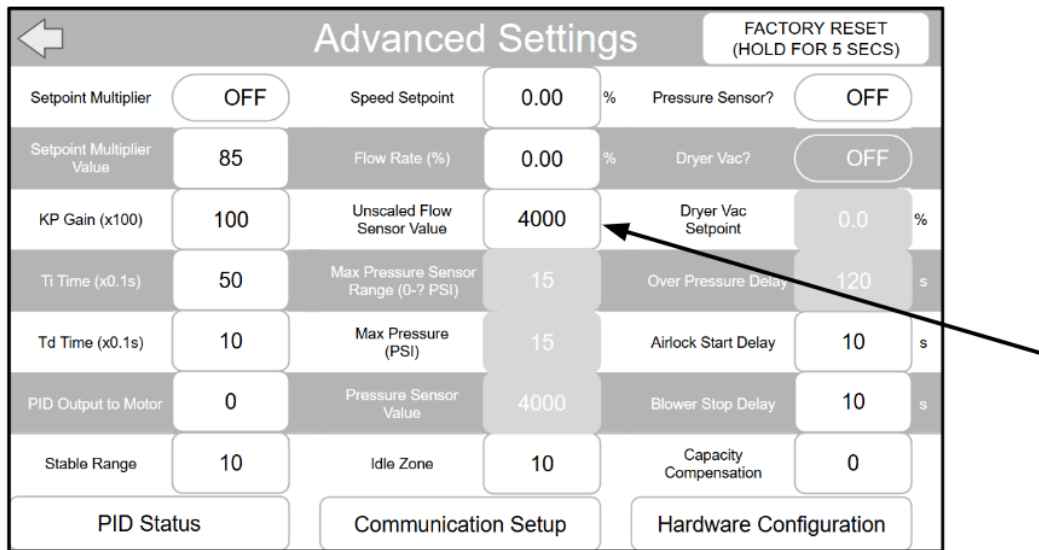

Figure 5-44: Confirmation of air velocity sensor connectivity

17. If the system utilizes a pressure sensor, press the toggle switch on the right side of the display to the “ON” position. Enter the maximum pressure, measured in psi, of the pressure sensor into the “Max Pressure Sensor Range” box.

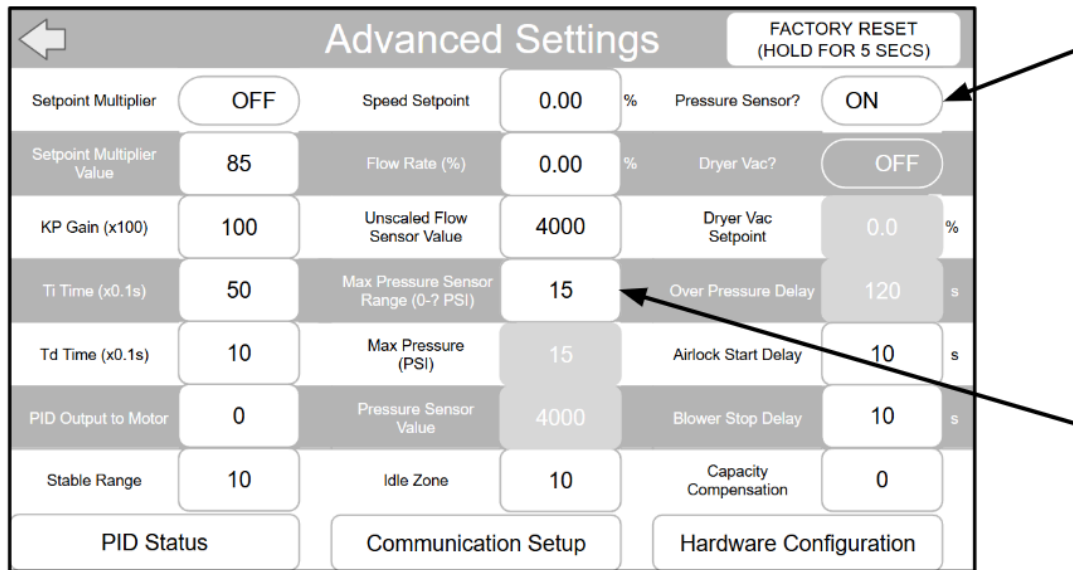

Figure 5-45: Optional pressure sensor configurations

18. Press the arrow in the top left corner of the display to return to the Settings screen.

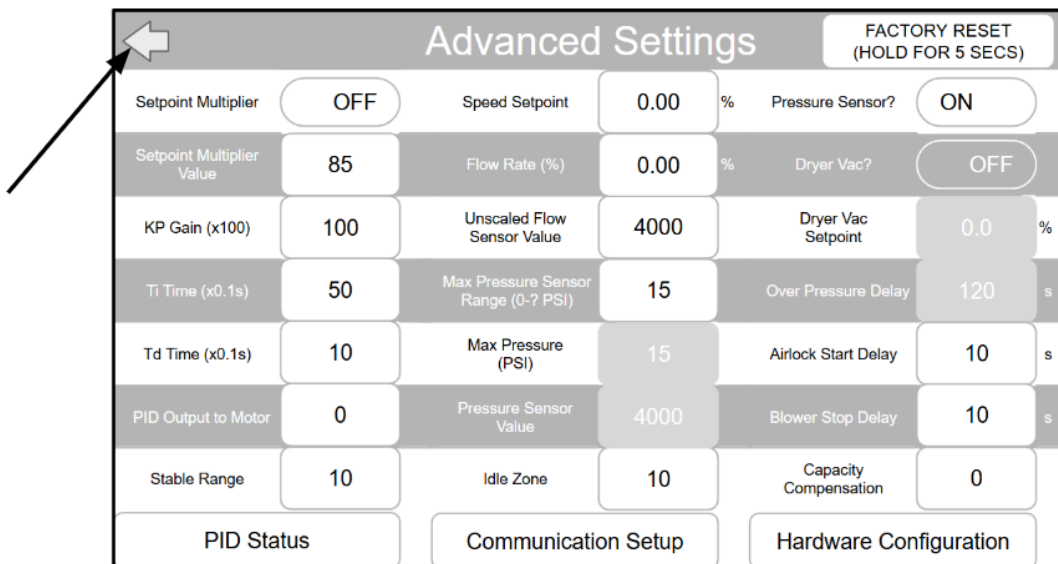

Figure 5-46: Return to Settings screen

19. Press the “Press to Calibrate” button to calibrate the air velocity sensor and allow the calibration sequence to run. This process will take approximately 30 seconds and will automatically determine the high and low limits of the air velocity sensor.

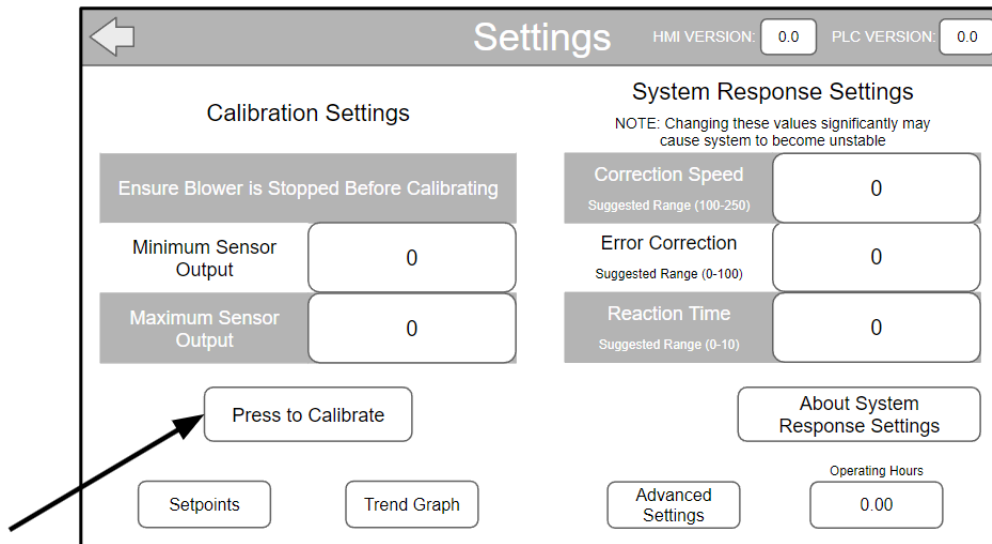

Figure 5-47: Air velocity sensor calibration

20. As necessary, make adjustments to any remaining settings, advanced settings, or configurations with reference to the *Controls* subsection of **Section 6: Operation**.

Connection to External Systems

The Smart-Flo system can be utilized in combination with external automation systems. The HMI of the Smart-Flo system is configured to output information over RS-485 Modbus from the **COM2** port located on the back of the HMI screen. Reference the auxiliary equipment's operator's manual for specific requirements for communication connections. Refer to **Table 5-2** and **Table 5-3** below for the specifications and parameters of the HMI for proper connection and communication with the system.

Table 5-2: HMI specifications

Item	Specification
Communication Type	RS-485 Modbus
Communication Speed	19,200 bps
Control Procedure	Asynchronous Communication System
Communication System	Half Duplex System
Data Length	8 bits
Stop Bits	1 bit
Parity Check	Even Parity

Table 5-3: HMI parameters

Parameter	Address	Bit	Scale	Unit	Type*
Confirm Run	62001	0	—	—	Read
System Fault	62001	1	—	—	Read
Blower Speed	62002	—	0.01	Hz	Read
Blower Load	62003	—	0.1	%	Read
System Pressure	62004	—	0.1	%	Read
Start System	62005	0	—	—	Read/Write
Manual Operation	62005	1	—	—	Read/Write
Auto Operation	62005	2	—	—	Read/Write
Setpoint	62006	—	0.1	%	Read/Write

***NOTE:** Read-only registers are input registers, Read/Write registers are holding registers.

STORAGE

To prevent unnecessary down-time when preparing the Smart-Flo system for use after storage, it is important to carefully follow the storage preparation procedures.

To prepare the Smart-Flo system for storage, proceed as follows:

1. Refer to the Ultra-Veyor operator's manual to prepare the complete system for storage.
2. Thoroughly inspect the Smart-Flo system for any damaged or worn components; repair or replace any components as required to prevent down-time after storage.
3. Clean the interior of the Smart-Flo system to remove any dirt, dust or debris. Reference **Section 7: Maintenance and Adjustments** for proper cleaning procedures.
4. With reference to **Section 7: Maintenance and Adjustments**, perform any required maintenance tasks.
5. Move the system to the storage location. The storage position should be indoors, dry, level, free of debris, and in an area that does not have frequent human activity.
6. If desired, install a protective covering, such as the protective plastic shipping covering, over the Smart-Flo system to protect it from dirt, dust, debris, and any moisture or liquid exposure.

After storage, refer to **Section 7: Maintenance and Adjustments** to ensure all necessary maintenance tasks are completed. Once the required maintenance tasks have been completed, proceed to the standard pre-operation checks as outlined in **Section 6: Operation** and resume normal operation.

END OF LIFE

Upon completion of the functional life of the Smart-Flo system, special care must be taken in disposal. Electronic components can release toxic elements harmful to both humans and the environment with improper disposal. Refer to your local regulations for disposal of electronic waste.



PAGE INTENTIONALLY LEFT BLANK



Operation

SMART-FLO 2.0 SYSTEM

MACHINE FEATURES AND COMPONENTS

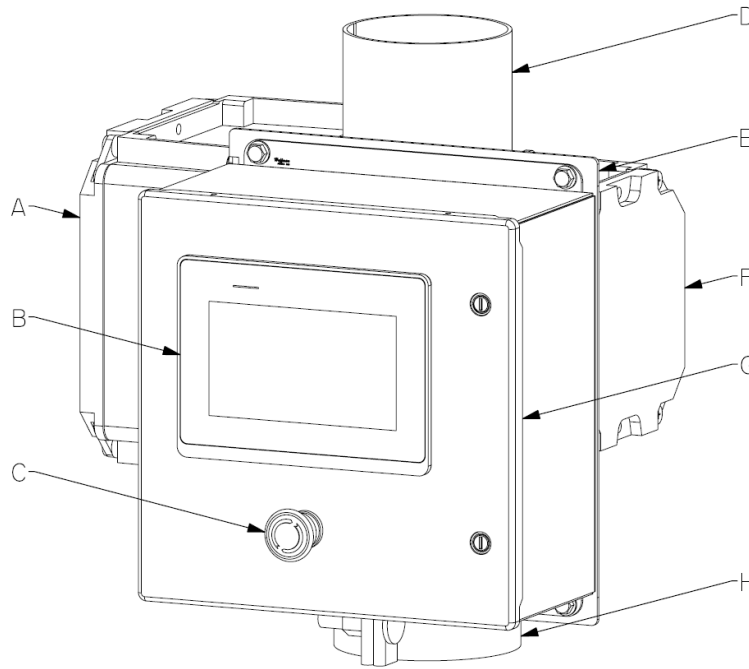

- A Counterweight Enclosure
- B HMI Screen
- C Emergency Stop Button
- D Air Velocity Sensor Tube
- E Frame
- F Signal Conditioner Enclosure
- G Control Panel Enclosure
- H Compression Coupling

Figure 6-1: Smart-Flo system key components

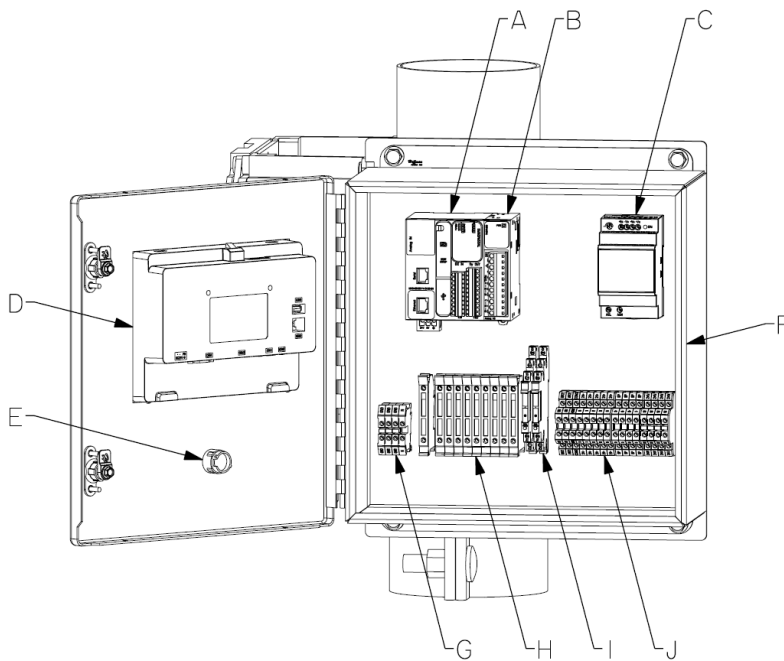

- A PLC Module
- B Analog Module
- C Power Supply
- D HMI Screen
- E Emergency Stop Button
- F Control Panel Enclosure
- G Single-Level Terminal Block
- H Fuse Block
- I Control Relay
- J Double-Level Terminal Block

Figure 6-2: Control panel enclosure key components

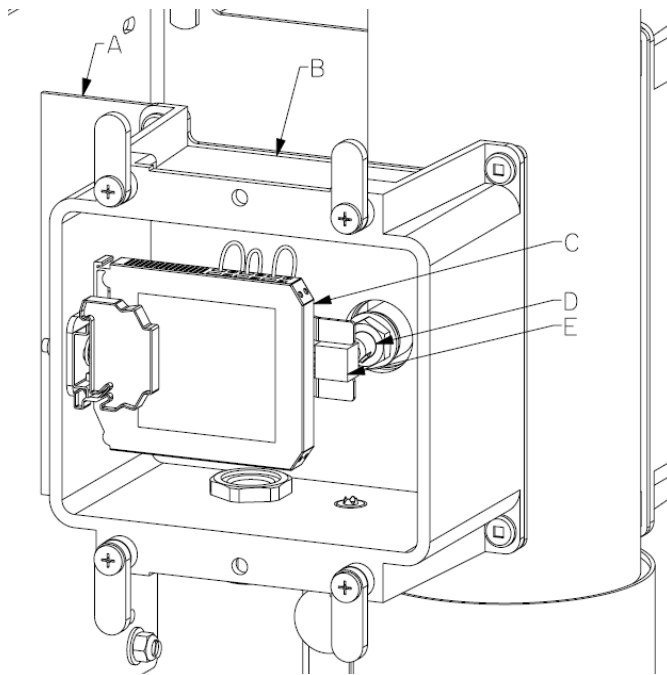

- A Frame
- B Signal Conditioner Enclosure
- C Signal Conditioner
- D Sensor Shaft
- E Potentiometer

Figure 6-3: Signal conditioner enclosure key components

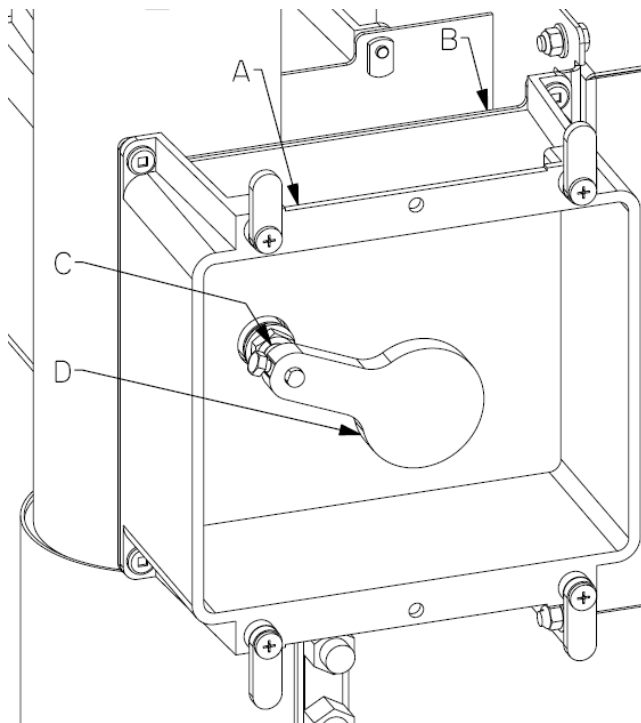

- A Counterweight Enclosure
- B Frame
- C Sensor Shaft
- D Counterweight

Figure 6-4: Counterweight enclosure key components

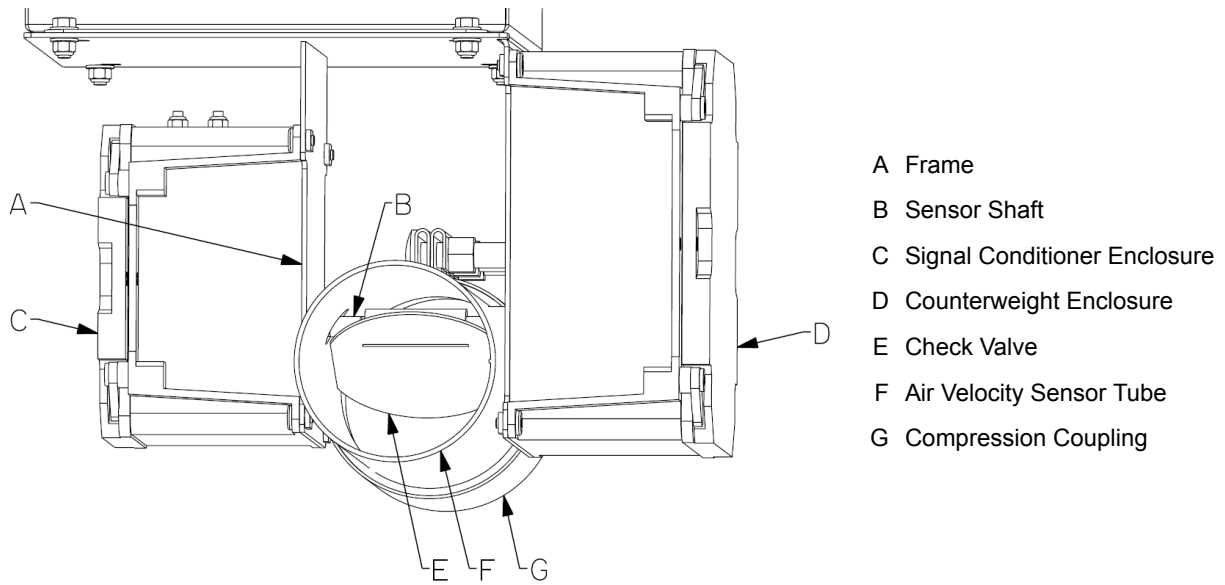

Figure 6-5: Air velocity sensor key components

CONTROLS AND DISPLAYS

The physical controls and displays of the Smart-Flo system, as illustrated in **Figure 6-1**, include the HMI screen (**Fig 6-1 B**) and the emergency stop button (**Fig 6-1 C**). Review **Figure 6-6** through **Figure 6-12** for the unique display screens of the HMI for operation, setting, and adjustment.

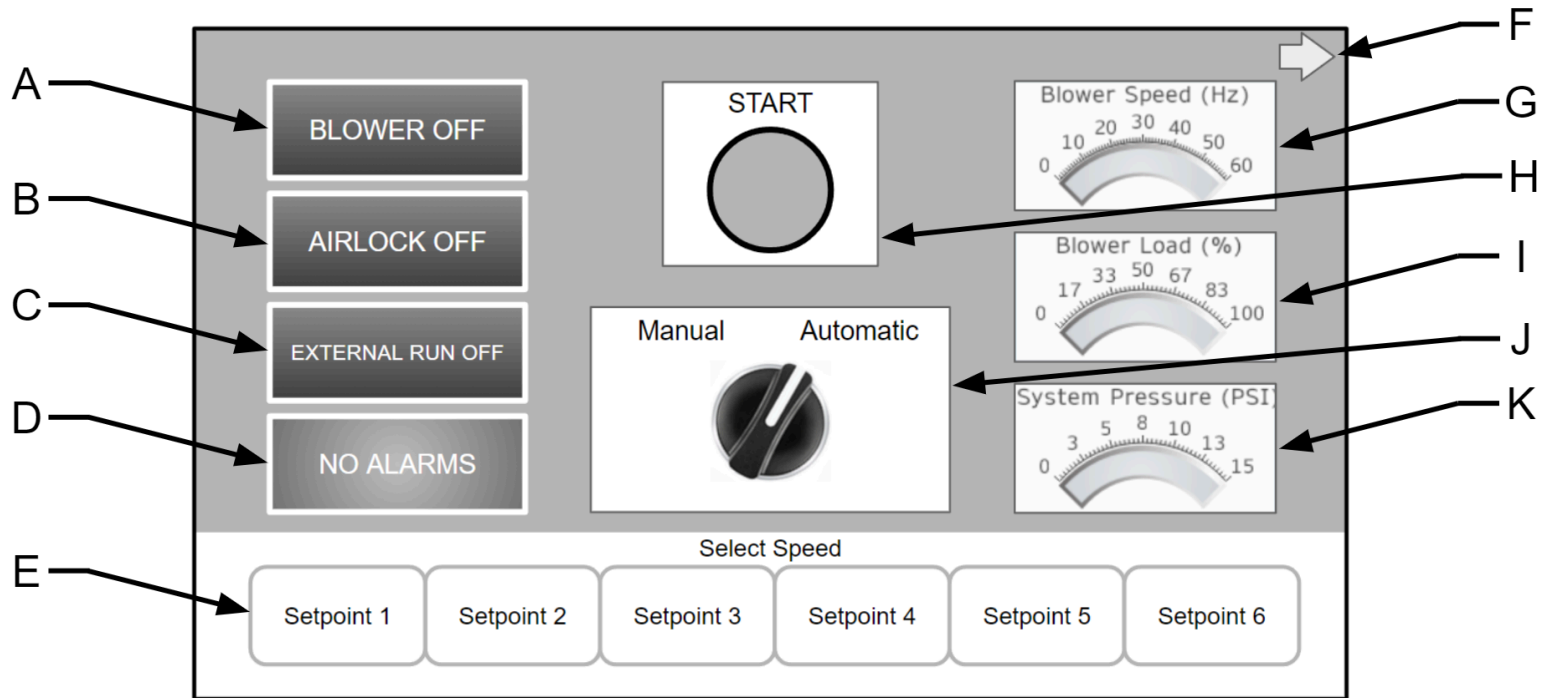

Figure 6-6: Home screen

Table 6-1: Home screen

Reference	Feature	Function	State/Range
Fig 6-6 A	Blower Indicator	Indicates the operating state of the blower.	ON / OFF
Fig 6-6 B	Airlock Indicator	Indicates the operating state of the airlock.	ON / OFF
Fig 6-6 C	External Run Indicator	Indicates whether the system is operating under an external run command.	ON / OFF
Fig 6-6 D	Alarm Indicator	Indicates whether there are any system alarms. Pressing this button will open the Alarms screen (Fig 6-7).	ALARM / NO ALARMS
Fig 6-6 E	Speed Selection Options	<i>Automatic Mode</i> : Sets the setpoint at which the system will operate. Pressing and holding an individual setpoint will open the Setpoints screen (Fig 6-8).	Six customizable setpoints
		<i>Manual Mode</i> : Individual speeds replaced by a single text box in which the operating speed may be entered	0 - 100 %
Fig 6-6 F	Screen Navigation Arrow	Provides access to the Settings screen (Fig 6-9).	—
Fig 6-6 G	Blower Speed (Hz)	<i>Modbus Control</i> : Displays the operational speed of the blower VFD. Value is read directly from the blower VFD.	0 - 60 Hz
	Blower Setpoint (%)	<i>Analog Control</i> : Displays the setpoint at which the system is running.	0 - 100 %
Fig 6-6 H	Start/Stop Button	Pressing this button will initiate the standard start-up or shut-down procedures.	START / STOP

Fig 6-6 I	Blower Load (%)	<i>Modbus Control:</i> Displays the percentage of the current blower VFD output to the maximum output.	0 - 100 %
	Sensor Feedback (%)	<i>Analog Control:</i> Displays the percentage of the current value of the air velocity sensor to the Maximum Sensor Output (Fig 6-9 E).	0 - 100%
Fig 6-6 J	Manual/Automatic Switch	Changes the operating mode of the system between <i>Manual</i> and <i>Automatic</i> .	MANUAL / AUTOMATIC
Fig 6-6 K	System Pressure	If the system is equipped with an optional pressure sensor, the current system pressure will be displayed.	0 - 15 psi
NOT SHOWN	Unplug Mode	<i>Automatic Mode:</i> Unavailable.	—
		<i>Manual Mode:</i> When activated, the blower will begin to operate at 18 Hz and will increase in speed by 1 Hz every 6 seconds, running for a total time of 5 minutes, unless stopped.	ON / OFF
NOT SHOWN	Dryer Vac	<i>Automatic Mode:</i> Unavailable.	—
		<i>Manual Mode:</i> When activated, the start delay for both the blower and airlock are set to 0 seconds. The blower will operate at a constant speed, as specified within the Advanced Settings screen (Fig 6-10).	ON / OFF

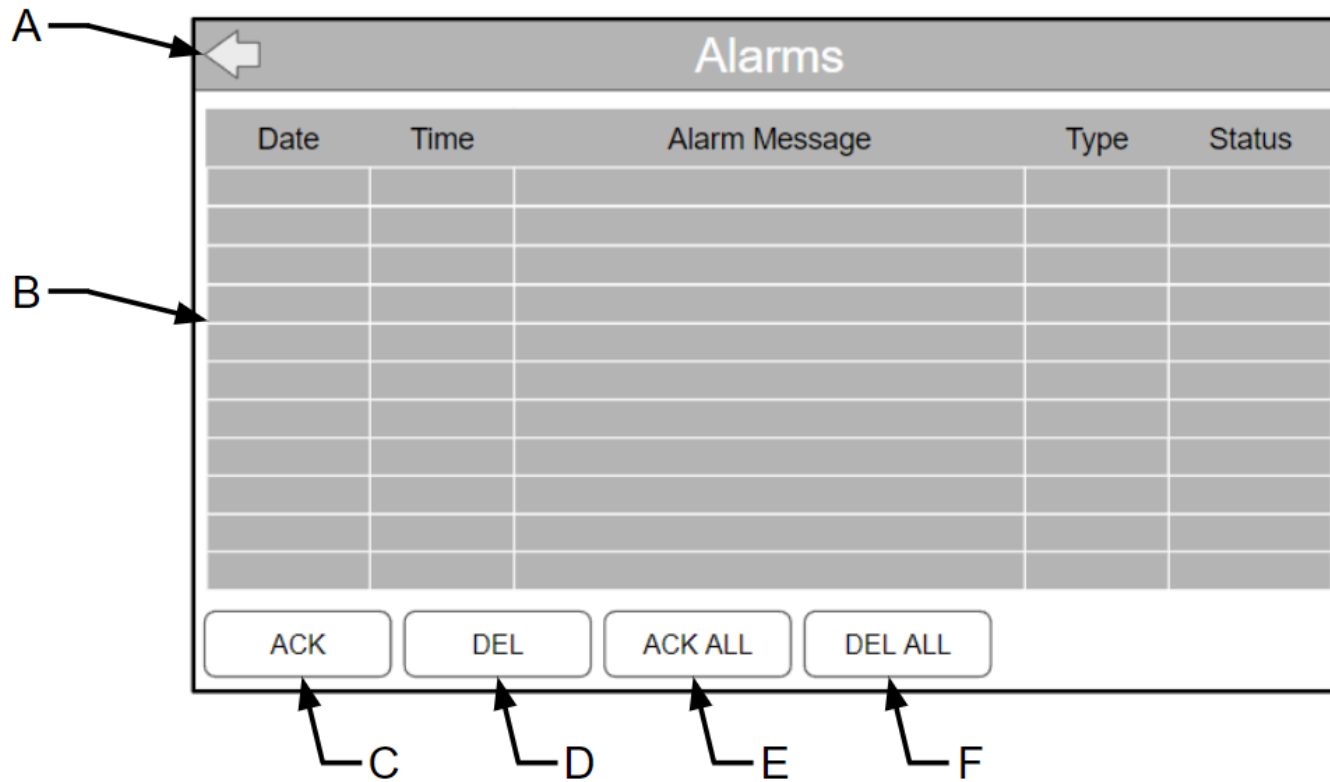

Figure 6-7: Alarms screen

Table 6-2: Alarms screen

Reference	Feature	Function
Fig 6-7 A	Screen Navigation Arrow	Provides access to the Home screen (Fig 6-6).
Fig 6-7 B	Alarms List	Displays the alarm date, time, message, type, and status. The alarms may be used as a diagnostic tool and should be monitored during operation. As a new alarm appears, it will be added to the alarm list, and the Alarm Indicator (Fig 6-6 D) will display the ALARM state and illuminate red.
Fig 6-7 C	ACK	Pressing this button will Acknowledge the highlighted alarm in the Alarms List. The alarm will remain in the Alarms List, but will be distinguishable from any new alarms
Fig 6-7 D	DEL	Pressing this button will Delete the highlighted alarm in the Alarms List.
Fig 6-7 E	ACK ALL	Pressing this button will Acknowledge All alarms in the Alarms List. All alarms will remain in the Alarms List, but will be distinguishable from any new alarms.
Fig 6-7 F	DEL ALL	Pressing this button will Delete All alarms in the Alarms List.

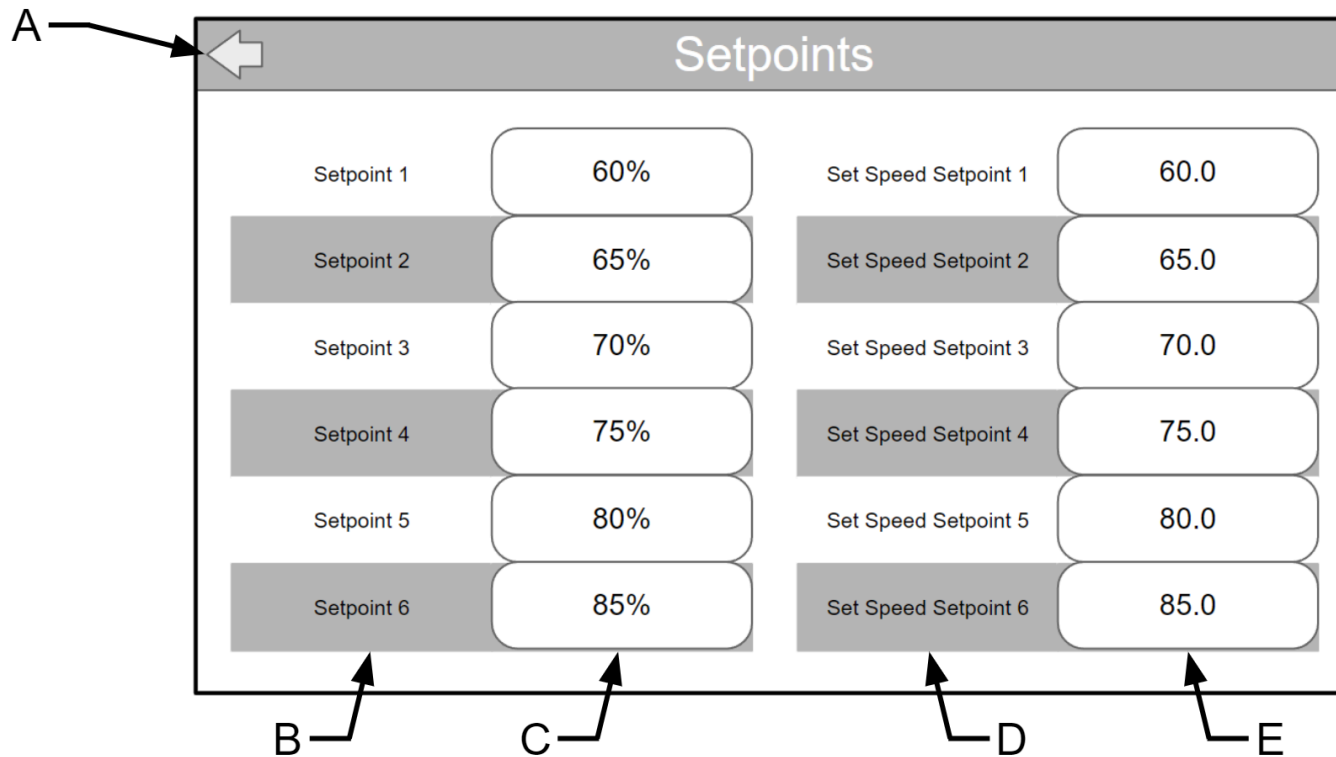

Figure 6-8: Setpoints screen

Table 6-3: Setpoints screen

Reference	Feature	Function	State/Range
Fig 6-8 A	Screen Navigation Arrow	Provides access to the Home (Fig 6-6) or Settings (Fig 6-9) screen.	—
Fig 6-8 B	Unique Setpoint	Label for each of the six unique setpoints.	—
Fig 6-8 C	Setpoint Name	Text box to enter a Name for each of the six Unique Setpoints.	<i>Any combination of letters, numbers, or characters</i>
Fig 6-8 D	Unique Setpoint Speed	Label for each of the six unique setpoint speeds.	—
Fig 6-8 E	Setpoint Speed	Text box to enter a value for specified setpoint. The value must be a percentage of the maximum blower speed.	0 - 100 %

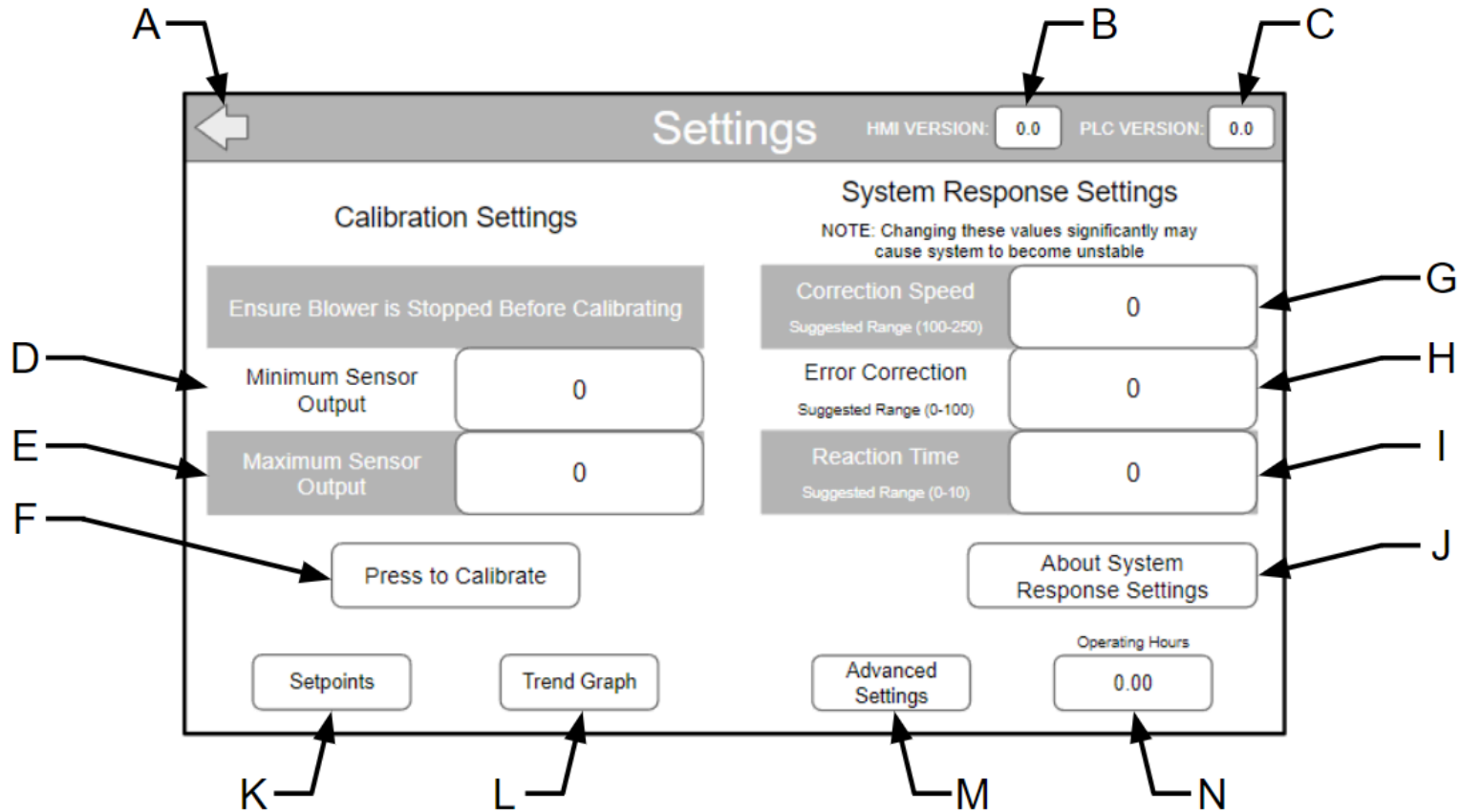

Figure 6-9: Settings screen

Table 6-4: Settings screen

Reference	Feature	Function	State/Range
Fig 6-9 A	Screen Navigation Arrow	Provides access to the Home screen (Fig 6-6).	—
Fig 6-9 B	HMI Version	Displays the current HMI program version installed and operating on the HMI system.	—
Fig 6-9 C	PLC Version	Displays the current PLC program version installed and operating on the PLC module.	—
Fig 6-9 D	Minimum Sensor Output	Displays the lower limit of the air velocity sensor's range. This value is automatically set during the calibration sequence initiated by pressing the Press to Calibrate button (Fig 6-9 F).	4000 - 4010
Fig 6-9 E	Maximum Sensor Output	Displays the upper limit of the air velocity sensor's range. This value is automatically set during the calibration sequence initiated by pressing the Press to Calibrate button (Fig 6-9 F).	6100 - 6300
Fig 6-9 F	Press to Calibrate	Pressing this button will initiate the calibration sequence. The blower must be OFF before initiation. The air velocity sensor output is read while the blower is OFF and this value is used to set the Minimum Sensor Output (Fig 6-9 D). The air velocity sensor output is then read while the blower is operating at the maximum speed and this value is used to set the Maximum Sensor Output (Fig 6-9 E).	—
Fig 6-9 G	Correction Speed	Displays the value of the Correction Speed parameter that influences the Proportional-Integral-Derivative (PID) settings. Increasing the parameter value will cause the system to react more quickly, however, the system's behavior may become more erratic as a result. The Correction Speed may be changed by pressing the text box and entering a new value. See also Fig 6-10 E .	100 - 250 <i>Recommended</i>

Fig 6-9 H	Error Correction	Displays the value of the Error Correction parameter that influences the PID settings. Increasing the parameter value will significantly decrease the difference between the measured system speed and the desired speed as specified by the Setpoint Speed (Fig 6-8 E), however, the time required for the system to reach a stable state will increase as a result. The Error Correction may be changed by pressing the text box and entering a new value. See also Fig 6-10 F .	0 - 100 <i>Recommended</i>
Fig 6-9 I	Reaction Time	Displays the value of the Reaction Time parameter that influences the PID settings. Increasing the parameter value will decrease the overshoot and required time for the system to become stable. However, increasing the value too much may cause the system to behave erratically. The Reaction Time may be changed by pressing the text box and entering a new value. See also Fig 6-10 G .	0 - 10 <i>Recommended</i>
Fig 6-9 J	About System Response Settings	Pressing this button will open a pop-up that displays detailed information regarding the system response parameters including Correction Speed (Fig 6-9 G), Error Correction (Fig 6-9 H), and Reaction Time (Fig 6-9 I).	—
Fig 6-9 K	Setpoints	Pressing this button will navigate to the Setpoints screen (Fig 6-8).	—
Fig 6-9 L	Trend Graph	Pressing this button will navigate to the Trend Graph Screen (Fig 6-11).	—
Fig 6-9 M	Advanced Settings	Pressing this button will navigate to the Advanced Settings screen (Fig 6-10).	—
Fig 6-9 N	Operating Hours	Displays the total time that the system has been run.	≥ 0.00

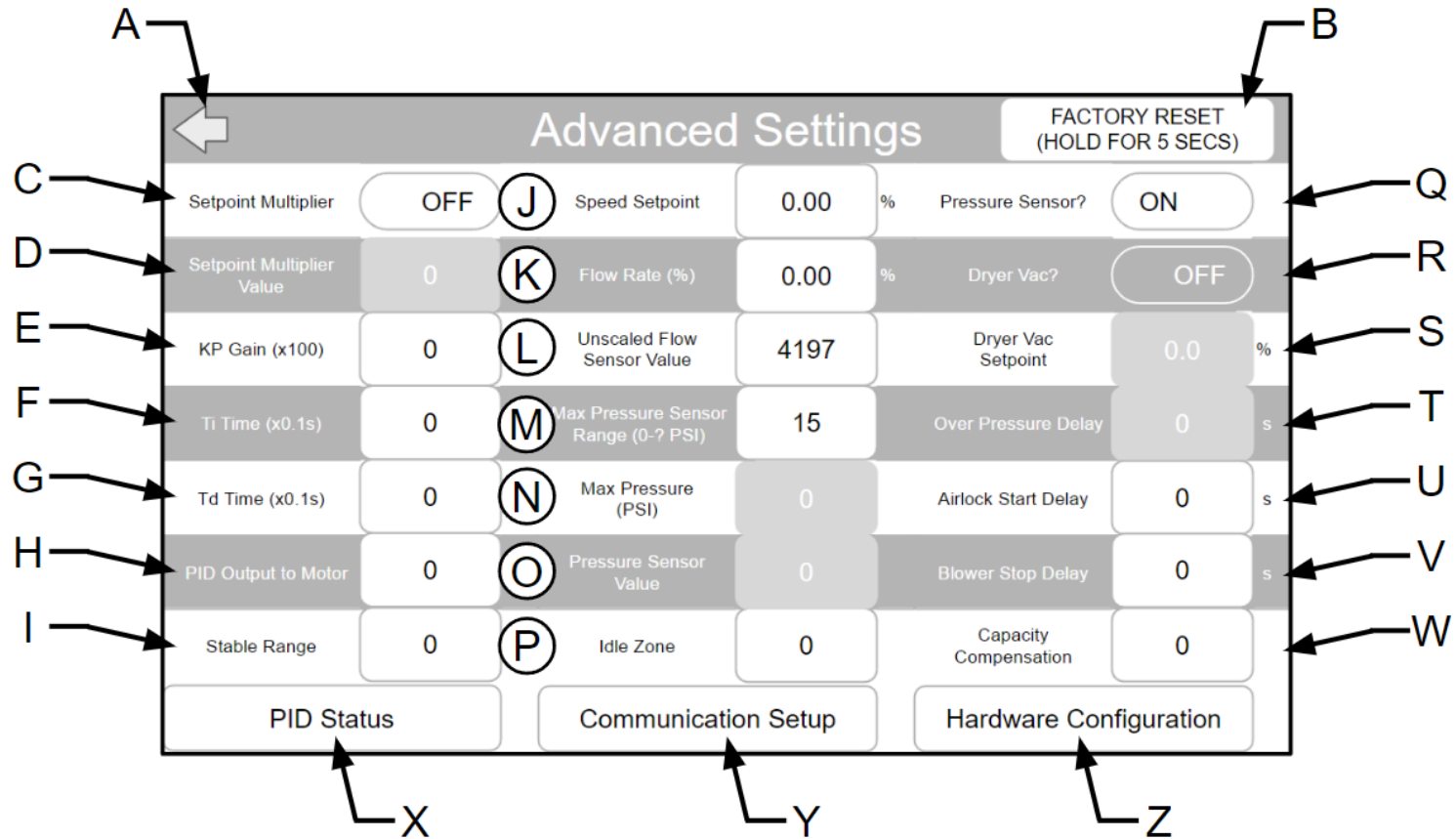

Figure 6-10: Advanced settings screen

Table 6-5: Advanced settings screen

Reference	Feature	Function	State/Range
Fig 6-10 A	Screen Navigation Arrow	Provides access to the Settings screen (Fig 6-9).	—
Fig 6-10 B	Factory Reset	Pressing and holding this button will set all settings setpoints to the default value. The reset will not alter any communication settings or Operating Hours (Fig 6-9 N)	—
Fig 6-10 C	Setpoint Multiplier	Pressing this switch will toggle the state of the Setpoint Multiplier. This feature assists the system to reach a higher frequency without alterations to the physical setup.	ON / OFF
Fig 6-10 D	Setpoint Multiplier Value	Displays the value of the Setpoint Multiplier Value parameter. This parameter alters the amount of compensation the system provides for moving product. Increasing the value will cause the system to operate at higher speeds. The Setpoint Multiplier Value may be changed by pressing the text box and entering a new value.	1 - 100
Fig 6-10 E	KP Gain (x100)	Displays the value of the KP Gain parameter that influences the PID settings. Increasing the parameter value will cause the system to react more quickly, however, the system's behavior may become more erratic as a result. The KP Gain may be changed by pressing the text box and entering a new value. See also Fig 6-9 G .	100 - 5000
Fig 6-10 F	Ti Time (x0.1s)	Displays the value of the Ti Time parameter that influences the PID settings. Increasing the parameter value will significantly decrease the difference between the measured system speed and the desired speed as specified by the Setpoint Speed (Fig 6-8 E), however, the time required for the system to reach a stable state will increase as a result. The Ti Time may be changed by pressing the text box and entering a new value. See also Fig 6-9 H .	0 - 1000

Fig 6-10 G	Td Time (x0.1s)	Displays the value of the Td Time parameter that influences the PID settings. Increasing the parameter value will decrease the overshoot and required time for the system to become stable. However, increasing the value too much may cause the system to behave erratically. The Td Time may be changed by pressing the text box and entering a new value. See also Fig 6-9 I .	0 - 500
Fig 6-10 H	PID Output to Motor	Displays the value of the output that is sent to the blower VFD. The value of the number is scaled to the required unit of the output and specific VFD model as required.	0 - 10000
Fig 6-10 I	Stable Range	Displays the range above and below the setpoint at which the PID loop is turned off. Once the motor output is within the Stable Range for 5 seconds or longer, the adjustments to the motor speed to reach the setpoint will stop, and the motor will continue to operate at the current speed. The total range of the motor output is 10000. If the system exceeds or drops below the Stable Range, the PID control will resume. This parameter aids in stabilizing the system operating speed. The Stable Range may be changed by pressing the text box and entering a new value.	0 - 5000
Fig 6-10 J	Speed Setpoint	Displays the value of speed setpoint specified by the user. This parameter is read only.	0 - 100 %
Fig 6-10 K	Flow Rate (%)	Displays the value of the actual speed that the air velocity sensor detects as the system is running compared to the maximum potential speed. This parameter is read only.	0 - 100 %
Fig 6-10 L	Unscaled Flow Sensor Value	Displays the unscaled amperage value read by the air velocity sensor. This value is used, after being scaled, for use in the system. This parameter is read only.	4000 - 20000

Fig 6-10 M	Max Pressure Sensor Range (0 - ? psi)	Displays the maximum pressure value that can be measured for the system. This parameter should be set as the maximum capacity of the pressure sensor used in the system. Refer to the operator's manual of the pressure sensor for its specific capacities. The Max Pressure Sensor Range may be changed by pressing the text box and entering a new value.	0 - 15
Fig 6-10 N	Max Pressure (psi)	Displays the maximum pressure at which the system can efficiently operate. Above this pressure, the system may plug or the motor may stall. This parameter may be used to shut down the airlock or dryer system. The Max Pressure parameter may be changed by pressing the text box and entering a new value.	0 - 15
Fig 6-10 O	Pressure Sensor Value	Displays the amperage value read by the pressure sensor. This parameter is read only.	4000 - 20000
Fig 6-10 P	Idle Zone	Displays the range above the setpoint before the systems will compensate for moving product. As the system begins to operate above this range, the blower speed will be increased to compensate for moving product. This parameter influences the steps for the Setpoint Multiplier (Fig 6-10 D). The Idle Zone parameter may be changed by pressing the text box and entering a new value.	0 - 2000
Fig 6-10 Q	Pressure Sensor?	Pressing this switch will toggle the state in regards to the presence or absence of a pressure sensor.	ON / OFF
Fig 6-10 R	Dryer Vac?	Pressing this switch will toggle the state in regards to the presence or absence of a dryer vac.	ON / OFF
Fig 6-10 S	Dryer Vac Setpoint	Displays the value for the setpoint at which the system will operate when the system is operating under Dryer Vac Mode. The Dryer Vac Setpoint may be changed by pressing the text box and entering a new value.	0 - 100 %

Fig 6-10 T	Over Pressure Delay	Displays the time, in seconds, for which the system may operate above the Max Pressure (Fig 6-10 N) before the system is shutdown. The Over Pressure Delay may be changed by pressing the text box and entering a new value.	0 - 100
Fig 6-10 U	Airlock Start Delay	Displays the time, in seconds, for which the start of the airlock is delayed upon initial startup of the system. During this period, only the blower will operate. The Airlock Start Delay may be changed by pressing the text box and entering a new value.	0 - 600
Fig 6-10 V	Blower Stop Delay	Displays the time, in seconds, for which the blower will continue to operate before it shuts down after the system STOP Button (Fig 6-6 H) has been pressed. During this period, the blower will operate at the maximum speed to clear the product from the conveying lines. The Blower Stop Delay may be changed by pressing the text box and entering a new value.	0 - 600
Fig 6-10 W	Capacity Compensation	Displays the amount by which the setpoint is increased when moving product. This value is influenced by the Setpoint Multiplier (Fig 6-10 D). This parameter is read only.	0 - 10000
Fig 6-10 X	PID Status	Pressing this button will display a live update of the current status of the PID. This parameter is read only.	UNDER SETPOINT / SETPOINT REACHED
Fig 6-10 Y	Communication Setup	Pressing this button will navigate to the Configuration screen (Fig 6-12).	—
Fig 6-10 Z	Hardware Configuration	Pressing this button will navigate to the Hardware Configuration screen.	—

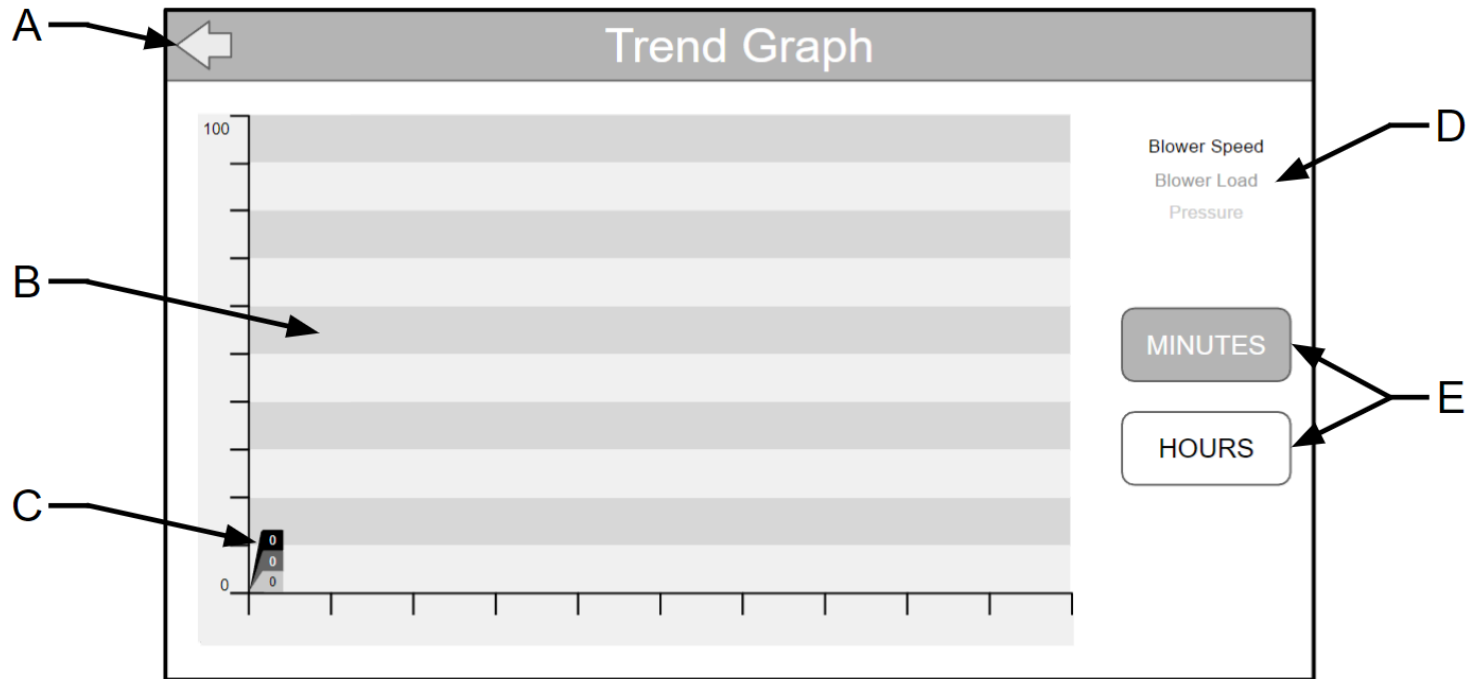

Figure 6-11: Trend graph screen

Table 6-6: Trend graph screen

Reference	Feature	Function
Fig 6-11 A	Screen Navigation Arrow	Provides access to the Settings screen (Fig 6-9).
Fig 6-11 B	Trend Graph Plot	Displays values as indicators to the system performance and can provide references for diagnostic information and as a diagnostic tool.
Fig 6-11 C	Trend Lines	Displays a graphical representation of the values of each individual measurement listed in the Legend (Fig 6-11 D).
Fig 6-11 D	Legend	Displays the reference for the Trend Line (Fig 6-11 C). The Trend Graph Plot (Fig 6-11 B) can display values for the Blower Speed (Fig 6-6 G), the Blower Load (Fig 6-6 I), and the System Pressure (Fig 6-6 K).
Fig 6-11 E	Time Scale Selector	Pressing the Time Scale Selector buttons will toggle the time scale (x-axis) of the Trend Graph Plot (Fig 6-11 B), the time scale may be alternated between 2 seconds, 2 minutes, and 2 hours.

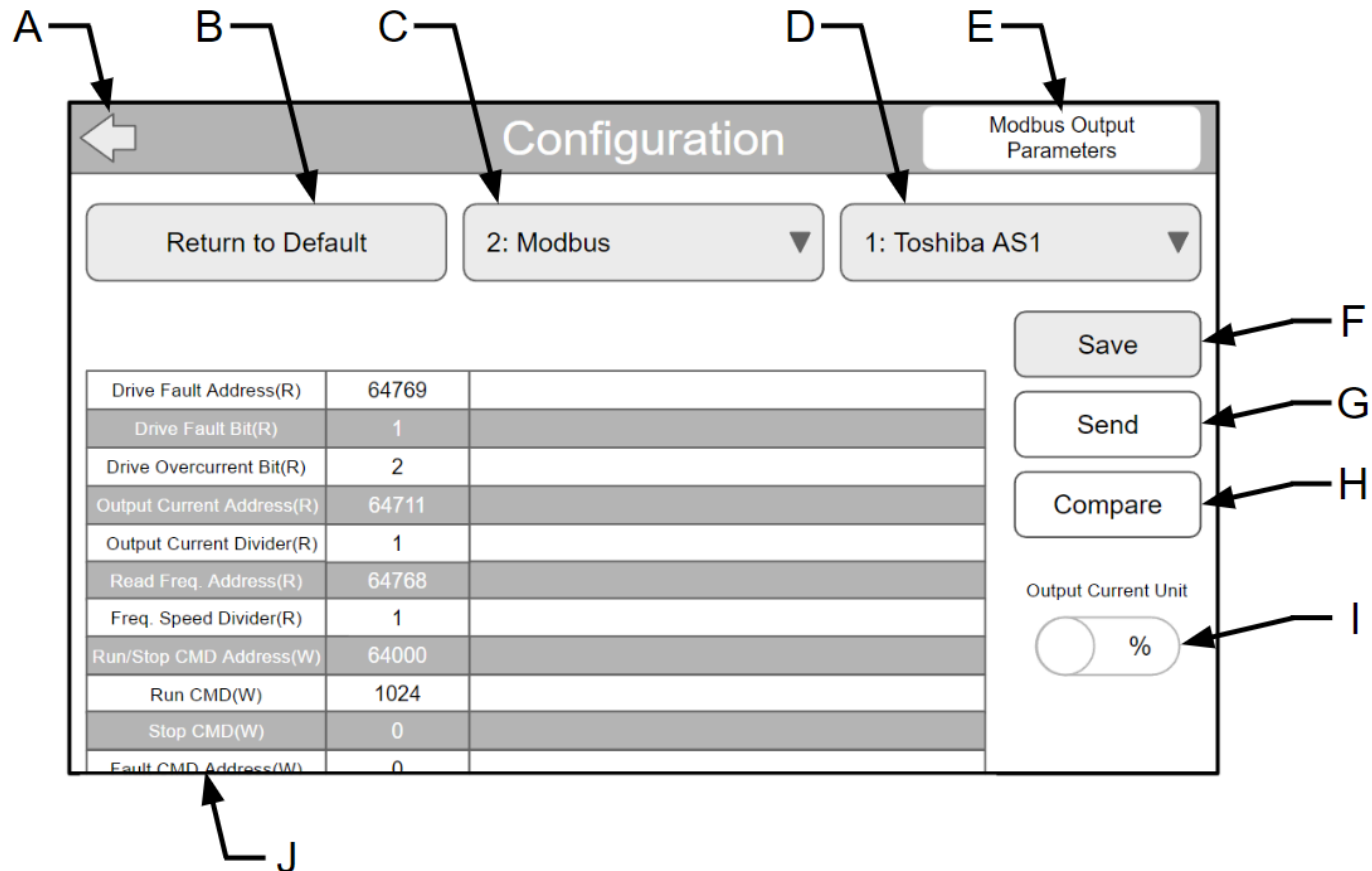

Figure 6-12: Configuration screen

Table 6-7: Configuration screen

Reference	Feature	Function	State/Range
Fig 6-12 A	Screen Navigation Arrow	Provides access to the Advanced Settings screen (Fig 6-9).	—
Fig 6-12 B	Return to Default	Pressing this button will return all Communication Parameters (Fig 6-12 J) to the default values. However, if the Save button (Fig 6-12 F) has been pressed, the default settings will be overwritten and unretrievable.	—
Fig 6-12 C	Communication Mode	Pressing this button will activate a drop-down menu where the type of communication between the PLC and blower VFD may be selected. The selected mode will alter the displayed Communication Parameters (Fig 6-12 J).	1: Analog 2: Modbus 3: Ethernet
Fig 6-12 D	VFD Model	Pressing this button will activate a drop-down menu where the make and model of the blower VFD may be selected. The selected make and model will update the displayed Communication Parameters (Fig 6-12 J). If 7: Other is selected, any additional required communications parameters may be entered. Refer to the operator's manual of the VFD for required parameters. This is only required for systems using Modbus and ethernet communication.	1: Toshiba AS1 2: Toshiba S15 3: Toshiba AS3 4: Delta C2000 5: Schneider ATV320 6: TECO A510 7: Other
Fig 6-12 E	Modbus Output Parameters	Pressing this button will navigate to the Output Modbus Communication Parameters screen which provides information to connect and control the Smart-Flo system to any external device in RS-485 communication.	—
Fig 6-12 F	Save	Pressing this button will manually save the Communication Parameters and store the values on the HMI and PLC. This action will overwrite the default values, meaning pressing the Return to Default button (Fig 6-12 B) will not retrieve the original values. During operation, the system will automatically save the Communication Parameters approximately every 5 minutes. After pressing the Save button, a pop-up will appear verifying the successful manual save.	—

Fig 6-12 G	Send	Pressing this button will send the Communication Parameters to the PLC. Sending the parameter values will set the communication parameters from the PLC to the VFD. If any parameters are altered, they must be sent to the PLC for the alterations to take effect. This action does not save the parameters, meaning if the alterations don't function as intended, they may be reversed by pressing the Return to Default button (Fig 6-12 B).	—
Fig 6-12 H	Compare	Pressing this button will compare the parameter values of the PLC to those entered on the HMI (Fig 6-12). This action may be used as a check to ensure the correct values have been sent to the PLC.	—
Fig 6-12 I	Output Current Unit	Pressing this toggle switch will change the unit of the Output Unit Address (R) parameter (Fig 6-12 J-4). By default the unit is set to %, however, if necessary the units may be changed to Amps. If changed to Amps, the motor's rated current will be used by other parameters and settings as required in place of the percentage output.	% / A
Fig 6-12 J*	Communication Parameters	<p>The Communication Parameters are required to attain proper communication between the HMI, PLC, and VFD. There are a combination of read (R) parameters and write (W) parameters.</p> <p>◆Some parameters may use an integer to simulate a binary value. To determine the corresponding integer, calculate 2^n where n is the required bit for the parameter as determined from the operator's manual of the VFD. It may also be possible to determine the required binary number from the VFD's operator's manual and then use a binary to integer calculator to determine the corresponding integer value.</p>	—
	1	Drive Fault Address (R)	Displays the address of the Modbus register from which the fault status of the VFD is read.

Fig 6-12 J*	2	Drive Fault Bit (R)	Displays the bit that will be monitored at the fault address to determine the presence of a drive fault. If the VFD is in a fault state, this bit will be true at the fault address.	2^n <i>(Integer representing binary value)</i> ♦
	3	Drive Overcurrent Bit (R)	Displays the bit that will be monitored at the fault address to determine the presence of a drive overcurrent alarm. If the VFD is in an alarm state, this bit will be true at the fault address.	2^n <i>(Integer representing binary value)</i> ♦
	4	Output Current Address (R)	Displays the address of the Modbus register from which the output current from the VFD to the motor is read. By default, the unit is 0.1%, however, the unit may be changed by pressing the Output Current Unit toggle switch (Fig 6-12 I), if required.	0 - 65536
	5	Output Current Divider (R)	Displays the divider required to change the decimal value of the % unit of the Output Current Address (Fig 6-12 J-4) from 0.01 Hz by any factor.	1^+
	6	Read Freq. Address (R)	Displays the address of the Modbus register from where the frequency of the VFD is read.	0 - 65536
	7	Freq. Speed Divider (R)	Displays the divider to change the decimal value of the Hz unit of Read Freq. Address (Fig 6-12 J-6) from 0.01 Hz by any factor. The default value is 1.	1^+
	8	Run/Stop CMD Address (W)	Displays the address of the Modbus register to where the run command of the VFD will be written.	0 - 65536
	9	Run CMD (W)	Displays the integer representation of the binary value that will send the start command to the blower VFD, in correspondence with the start command bit.	2^n <i>(Integer representing binary value)</i> ♦
	10	Stop CMD (W)	Displays the integer representation of the binary value that will send the stop command to the blower VFD, in correspondence with the stop command bit.	2^n <i>(Integer representing binary value)</i> ♦

Fig 6-12 J*	11	Fault CMD Address (W)	Displays the address of the Modbus register to where the fault command to the blower VFD is written.	0 - 65536
	12	Fault CMD (W)	Displays the integer representation of the binary value that will send the fault command to the blower VFD, in correspondence with the fault command bit.	2 ⁿ <i>(Integer representing binary value)</i> ♦
	13	Fault Reset Address (W)	Displays the address of the Modbus register to where the fault reset command to the blower VFD is written.	0 - 65536
	14	Fault Reset CMD (W)	Displays the integer representation of the binary value that will send the fault reset command to the blower VFD, in correspondence with the fault reset command bit.	2 ⁿ <i>(Integer representing binary value)</i> ♦
	15	Write Freq. Address (W)	Displays the address of the Modbus register to where the required frequency to the VFD is written.	0 - 65536
	16	RS-485 VFD Number (R)	Displayed the number assigned to the VFD. The value may be altered for systems in which the Smart-Flo system must communicate with multiple devices in the same network. The default value is 1.	1
	17*	Ingredient Number	Displays the internal variable required by the PLC. The value is used to identify the ingredient selected for communication. This parameter is read only.	1 - 7

***NOTE:** When the communication mode is set to Analog, all of the communication parameters (**Fig 6-12 J**) should be set to zero, except for the Ingredient Number (**Fig 6-12 J-17**).

† NOTE: Refer to the operator's manual of the VFD. Some VFD models may require a different Divider value.

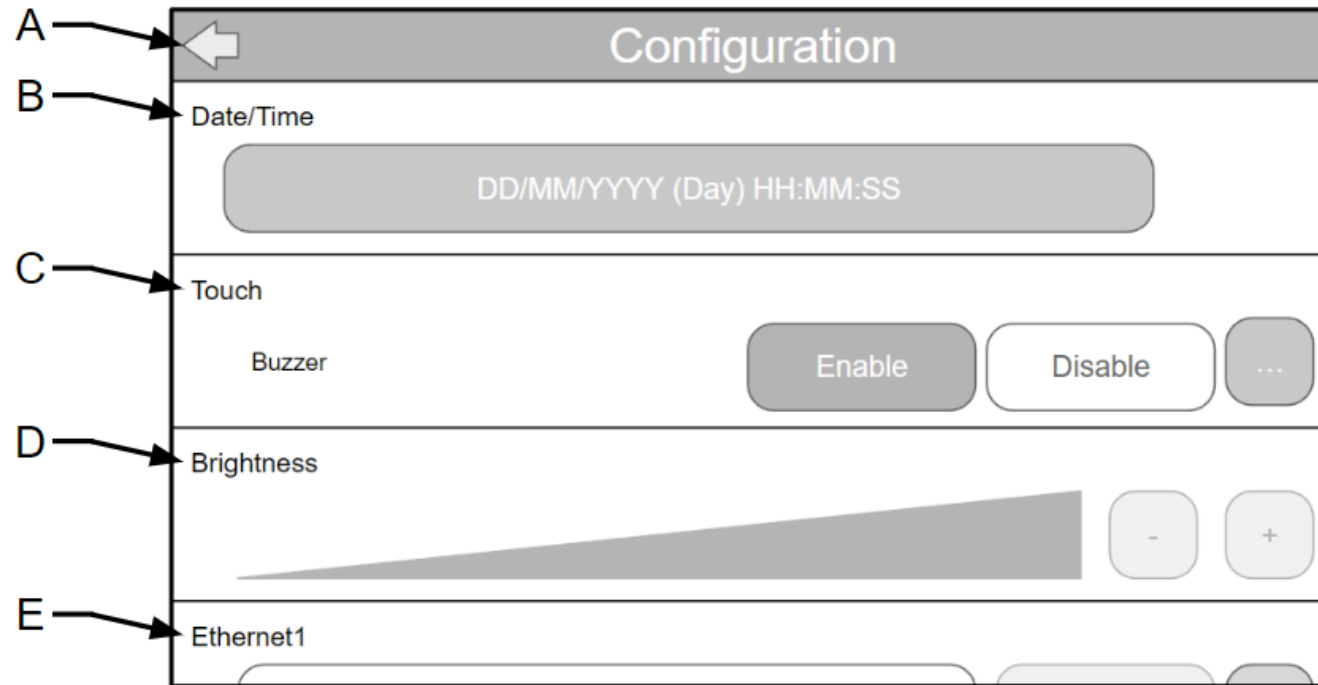

Figure 6-13: Hardware Configuration screen

Table 6-8: Hardware Configuration screen

Reference	Feature	Function	State/Range
Fig 6-13 A	Screen Navigation Arrow	Provides access to the Advanced Settings screen (Fig 6-9).	—
Fig 6-13 B	Date/Time	Displays the current date, weekday, and time. It may be changed by pressing the text box and entering new values.	DD / MM / YYYY (Weekday) HH : MM : SS
Fig 6-13 C	Touch	Provides the ability to enable or disable the buzzer and other touch settings.	ENABLE / DISABLE
Fig 6-13 D	Brightness	Provides the ability to adjust the brightness of the HMI display.	—
Fig 6-13 E	Ethernet1	Displays the primary ethernet address. The address must be set to 192.168.000.020, if not, the value may be changed by pressing the text box and entering a new value.	192.168.000.020
Fig 6-13 F*	Ethernet2	Displays the secondary ethernet address. The address must be set to 192.168.001.020, if not, the value may be changed by pressing the text box and entering a new value.	192.168.001.020
Fig 6-13 G*	Drivers	Provides access to settings and information for the drivers.	—
Fig 6-13 H*	Scan Rates	Provides access to settings and information for the scan rates.	—
Fig 6-13 I*	Version Information	Displays the current version for each of Product, Buildtime, and Runtime, that is operating in the HMI system.	### ### ###
Fig 6-13 J*	Download From	Provides the ability to select which device from which a system update will be downloaded.	USB / SD
Fig 6-13 K*	Upload To	Provides the ability to select which device to which the system information will be uploaded.	USB / SD
Fig 6-13 L*	Reboot	Provides the ability to shutdown or reboot the system.	SHUTDOWN / REBOOT
Fig 6-13 M*	System Log	Provides access to the system logs.	—

*Not shown in **Figure 6-13**, can be accessed by navigating down the screen.

OPERATION

Pre-Operation Machine Preparation

For personal safety and to ensure the Smart-Flo system is in good mechanical condition, the following checks must be performed before operation of the system:

1. Clear the area of bystanders, especially small children.
2. Ensure the Smart-Flo system has been properly serviced and maintained as per the described methods and schedule as outlined in **Section 7: Maintenance and Adjustments**.
3. Refer to the operator's manual of the auxiliary equipment to ensure the Smart-Flo system is sufficiently powered and properly connected to the external system.
4. Refer to the auxiliary equipment's operator's manual and perform any required pre-operation preparation.
5. Ensure the counterweight rotates freely through its entire range of motion.
6. Ensure the power sources for the control panel, blower, and airlock have not been locked-out. If locked-out, identify the cause and retrieve the tag before engaging power.
7. Ensure all mechanical locking devices, anchor chains, and transport or storage devices that would hinder or prohibit the normal function of the system have been removed. Serious damage to the machine and/or personal injury to the operator or bystanders may result from attempting to operate the machine while mechanical locking devices are in place.
8. Close and secure all guards, shields and access points.

Operation of the Machine

The following are the general operating guidelines for the Smart-Flo system:

1. Clear the area of bystanders, especially small children.
2. Ensure all guards, shields and access points have been closed and secured.
3. Ensure the power sources for the control panel, blower, and airlock have not been locked-out. If locked-out, identify the cause and retrieve the tag before engaging power.
4. Engage power to the control panel and system.
5. Select the desired mode of operation, with reference to **Figure 6-6 J**.

6. Select or set the desired operational speed of the blower, reference **Figure 6-6 E**.
7. Press the *START* button, reference **Figure 6-6 H**.
8. Only the blower will operate for a set period of time, as specified by the *Airlock Start Delay (Figure 6-10 U)*, after which the airlock will begin to operate.
9. Wait to allow the blower speed to stabilize at the desired operating speed.
10. Monitor the pressure gauge to ensure there are no obstructions in the system.
11. Refer to the auxiliary equipment's operator's manual and proceed with normal operation of the system.

Stopping the Machine

The following are the general stopping guidelines for normal operation of the Smart-Flo system:

1. Press the *STOP* button on the screen of the HMI, reference **Figure 6-6 H**.
2. Wait for the Smart-Flo system to complete its standard programmed shutdown procedures. The airlock will immediately stop when the *STOP* button is pressed, while the blower will continue to operate for a set period of time, as specified by the *Blower Stop Delay (Figure 6-10 V)*.
3. Once the blower has stopped, disengage the power to the control panel and system.
4. With reference to **Section 7: Maintenance and Adjustments** and any auxiliary equipment's operator's manual, review the maintenance schedules and perform any required maintenance on the system.
5. Proceed to prepare the Smart-Flo system for storage, if required, with reference to **Section 5: Machine Life-Cycle Procedures**.

In emergency situations, for example, if the safety of a person is threatened, it may be necessary to immediately shut-down the Smart-Flo system. To avoid potential damage to the Smart-Flo system and other components, the following should only be used in an emergency situation.

To shut-down the Smart-Flo system in an emergency, proceed as follows:

1. Press the *Emergency Stop Button*, reference **Figure 6-1 C**.

TROUBLESHOOTING

Reference **Table 6-9** for assistance with some of the most common issues, causes and solutions that you may face during the operation of your Smart-Flo system. If you encounter a problem that is difficult to solve, even after having referenced the following table and the troubleshooting guide of any auxiliary equipment's operator's manual, please contact your Walinga dealer or representative. Before you call, please have your operator's manual and your Smart-Flo system's serial number ready and available.

For detailed procedures for the solutions, reference **Section 5: Machine Life-Cycle Procedures**, **Section 6: Operation** and **Section 7: Maintenance and Adjustments**.

Table 6-9: Troubleshooting for Smart-Flo system

ISSUE	CAUSE	SOLUTION
<p>System speed fluctuates more than 1-2 Hz, then shuts off</p>	<p>Restricted movement of the air velocity sensor shaft/check valve assembly</p>	<p>Examine the sensor shaft bearings in the counterweight enclosure and signal conditioner enclosure. If obstructed or polluted with dirt, dust or debris, thoroughly clean the bearings and assembly components.</p>
		<p>Loosen the sensor shaft lock nuts in the counterweight enclosure and signal conditioner enclosure slightly. Rotate the sensor shaft by hand to ensure it rotates freely.</p>
		<p>Rotate the sensor shaft by hand and examine the interior of the air velocity sensor tube for any interference with the check valve assembly. If the compression couplings are installed too tightly on the sensor tube, it may cause the tube to warp, interfering with the motion of the check valve assembly. Repair or replace any warped sensor tube.</p>

ISSUE	CAUSE	SOLUTION
System speeds up to full rpm	Incorrect motor direction	Refer to the auxiliary equipment's operator's manual of the blower and motor to ensure the motor is operating in the correct direction. Ensure any VFD direction parameters are correctly configured.
	Incorrect signal conditioner wiring	Refer to the electrical schematics to ensure the signal conditioner is properly connected to the potentiometer and analog module.
	Sensor failure	In the event of a sensor failure, contact your Walinga dealer or representative to replace the potentiometer.
System running slower than desired, or plugs unexpectedly	Incorrect setpoint/speed setting	Review the selected speed setpoint, or manually entered speed to ensure it is the desired speed for the operational conditions, Increase the setpoint or speed if necessary.
	Incorrect calibration	The system may need to be recalibrated. Run the calibration sequence for the air velocity sensor.
	Blockage in the system	Place the system into <i>Manual</i> and engage the <i>Unplug Mode</i> . Allow the system to proceed through the unplug sequence. If any blockage remains, refer to the auxiliary equipment's operator's manual to remove any obstructions from the blower or airlock. NOTE: Do NOT remove any guard or open any access door while the power is engaged. The rotating blades of the airlock and the rotating lobes of the blower can cause severe injury. Always lock-out the power before manually removing any blockage.



Maintenance and Adjustments

SMART-FLO 2.0 SYSTEM

MAINTENANCE PROCEDURES

Inspection of Air Velocity Sensor Assembly

To maintain proper function of the Smart-Flo system, the movement of the air velocity sensor shaft and check valve assembly must be unrestricted.

To inspect the air velocity sensor assembly, proceed as follows:

1. Clear the area of bystanders, especially small children.
2. Place all controls in the neutral or off position, disconnect and lock-out all power sources, including those to the control panel, blower, airlock and any auxiliary equipment, and wait for all moving parts to stop.
3. Remove the cover of the counterweight enclosure.

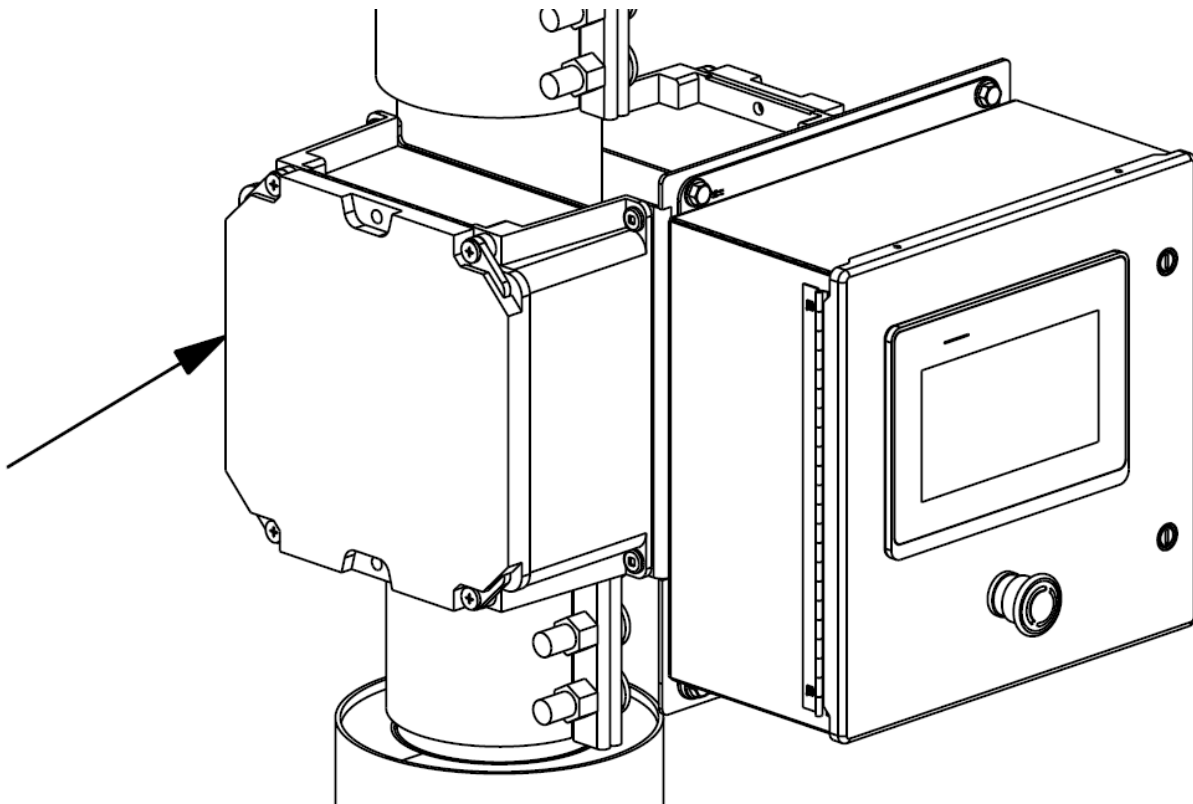

Figure 7-1: Counterweight enclosure cover

4. Rotate the counterweight by hand, through the full range of motion. The counterweight and sensor shaft should rotate freely, and should return to the resting position.

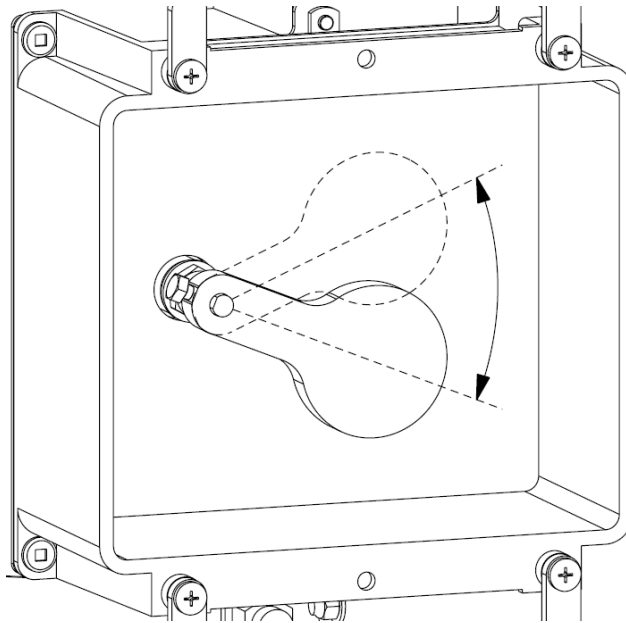

Figure 7-2: Counterweight range of motion

5. If the movement of the sensor shaft assembly is restricted or inhibited in any way, proceed as follows:
 - a. Remove the cover of the signal conditioner enclosure.

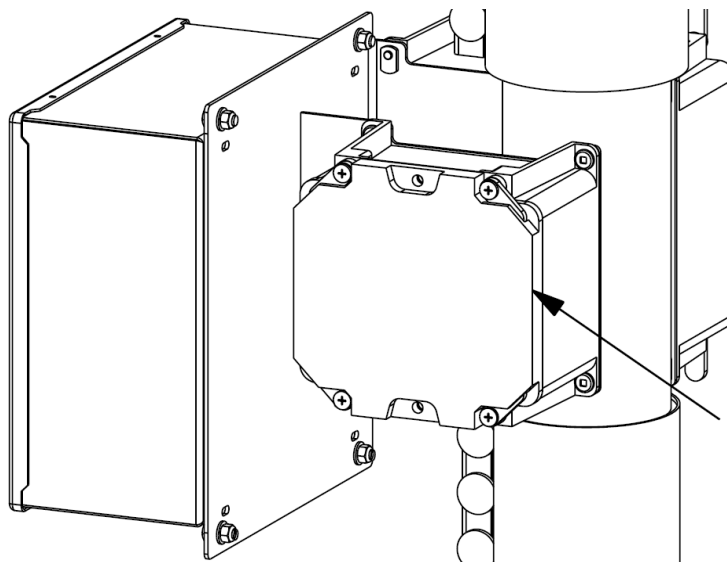

Figure 7-3: Signal conditioner enclosure cover

- b. Slightly loosen the sensor shaft lock nuts on both ends of the sensor shaft.

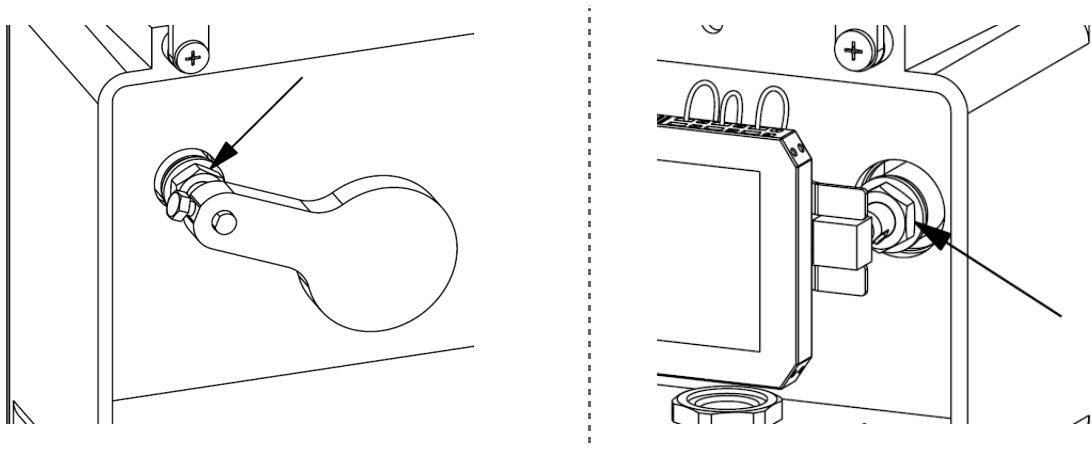

Figure 7-4: Sensor shaft lock nuts

- c. Rotate the counterweight by hand to determine if the movement has become unrestricted. If the movement has not improved, retighten both sensor shaft lock nuts.
- d. Refer to the auxiliary equipment's operator's manual to remove any components positioned above the Smart-Flo system, and remove the compression coupling located at the top of the air velocity sensor tube.

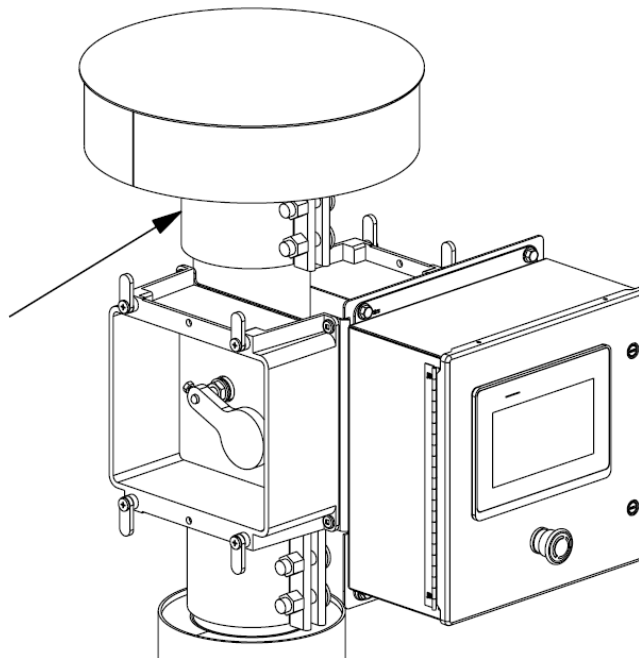

Figure 7-5: Air velocity sensor tube access

- e. Rotate the counterweight by hand and monitor the movement of the check valve assembly to determine if there is any interference with the air velocity sensor tube. Overtightening of the compression couplings may cause the tube to warp, interfering with movement.

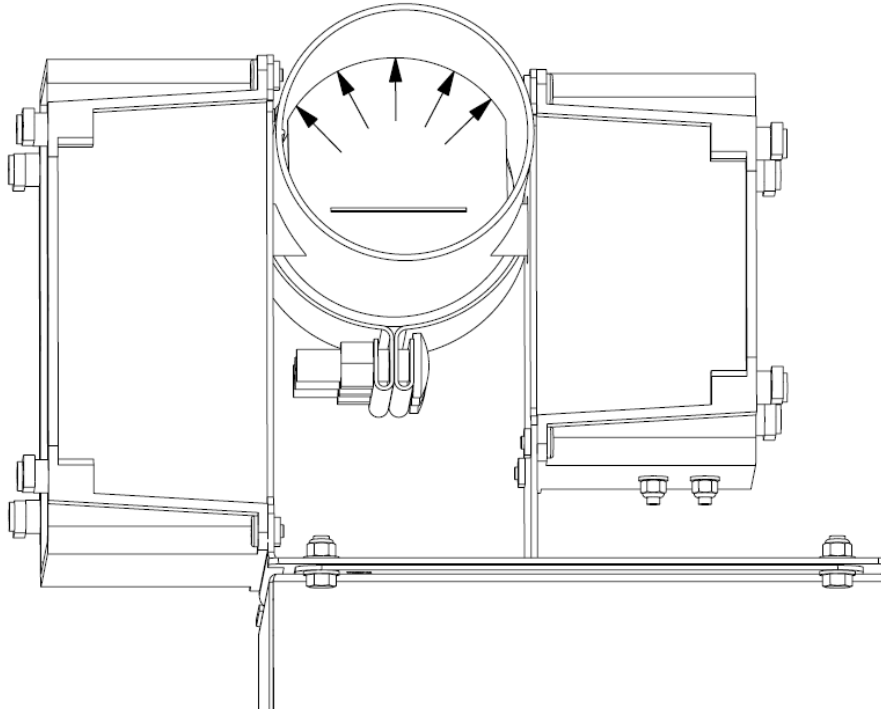

Figure 7-6: Check valve interference

- f. If the air velocity sensor tube has become warped or damaged in any way it must be repaired or replaced. Contact your local Walinga authorized service provider.
 - g. Accumulation of dirt, dust or debris within the sensor shaft bushing may impede movement. Refer to the procedures outlined in the following sub-section, *Cleaning of Air Velocity Sensor Assembly*, to properly clean the components.
 - h. Inspect the components of the sensor shaft and check valve assemblies for any signs of wear or damage. Repair or replace any damaged or worn components as required.
 - i. Reinstall and secure any removed components, with reference to the auxiliary equipment's operator's manual as required.
6. Reinstall the cover of the counterweight enclosure.
 7. Ensure all guards are closed and secured.

Cleaning of Air Velocity Sensor Assembly

To maintain unrestricted movement of the air velocity sensor assembly for proper function of the Smart-Flo system, the components of the air velocity sensor shaft and check valve assembly, and other internal components, assemblies and surfaces must be cleaned of any accumulated dirt, dust or debris.

To clean the internal components, proceed as follows:

1. Clear the area of bystanders, especially small children.
2. Place all controls in the neutral or off position, disconnect and lock-out all power sources, including those to the control panel, blower, airlock and any auxiliary equipment, and wait for all moving parts to stop.
3. Refer to the auxiliary equipment's operator's manual to remove any components positioned above the Smart-Flo system, and remove the compression coupling located at the top of the air velocity sensor tube.

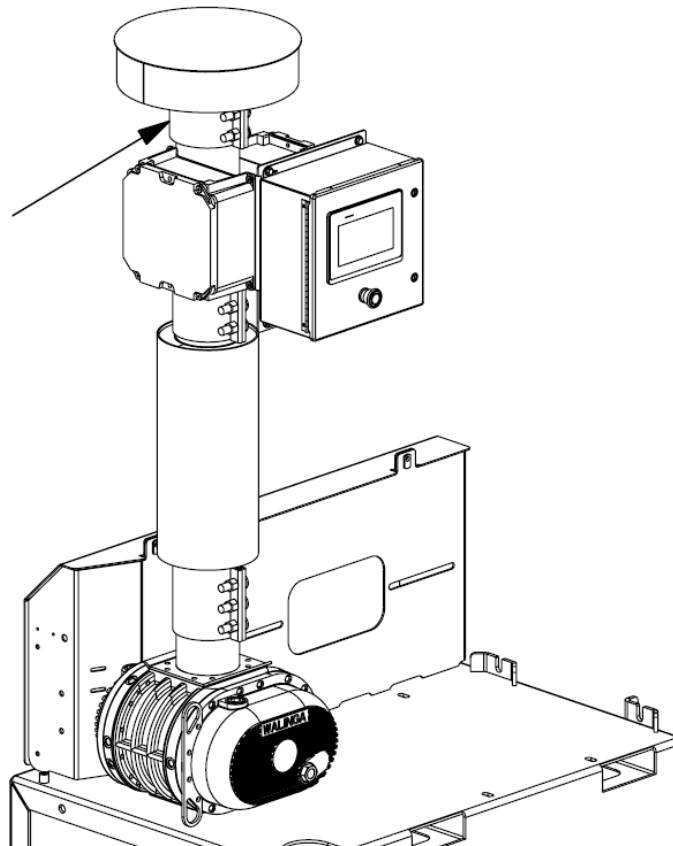

Figure 7-7: Upper component and assembly removal

4. Loosen the compression clamp located at the bottom of the Smart-Flo system and remove the Smart-Flo assembly from the blower package assembly.

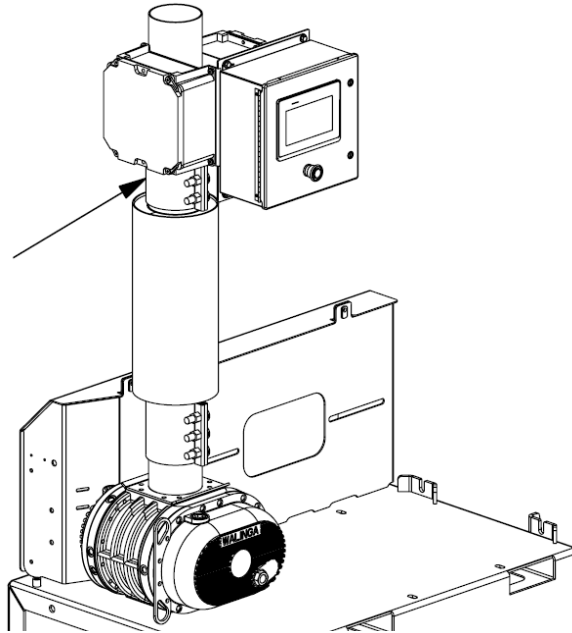

Figure 7-8: Removal from blower package

5. Remove the cover of the signal conditioner enclosure.

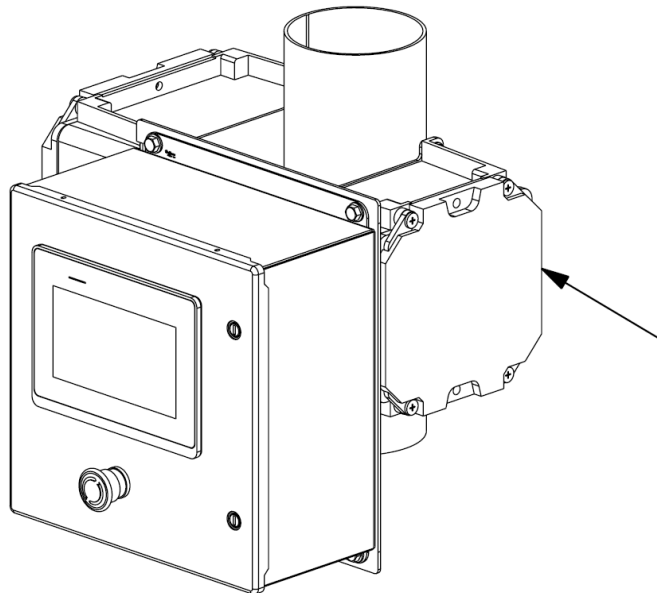

Figure 7-9: Signal conditioner enclosure cover

6. Use a felt tip marker to mark the position of the potentiometer and shaft for future reference.

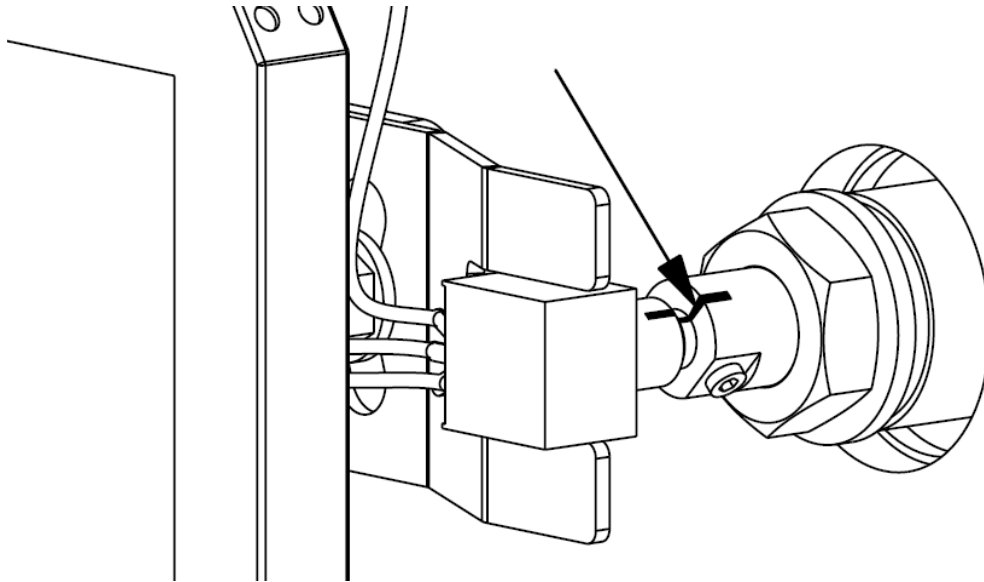

Figure 7-10: Potentiometer-shaft alignment marking

7. Loosen the potentiometer set screw on the sensor shaft and remove the potentiometer from the sensor shaft and mounting bracket.

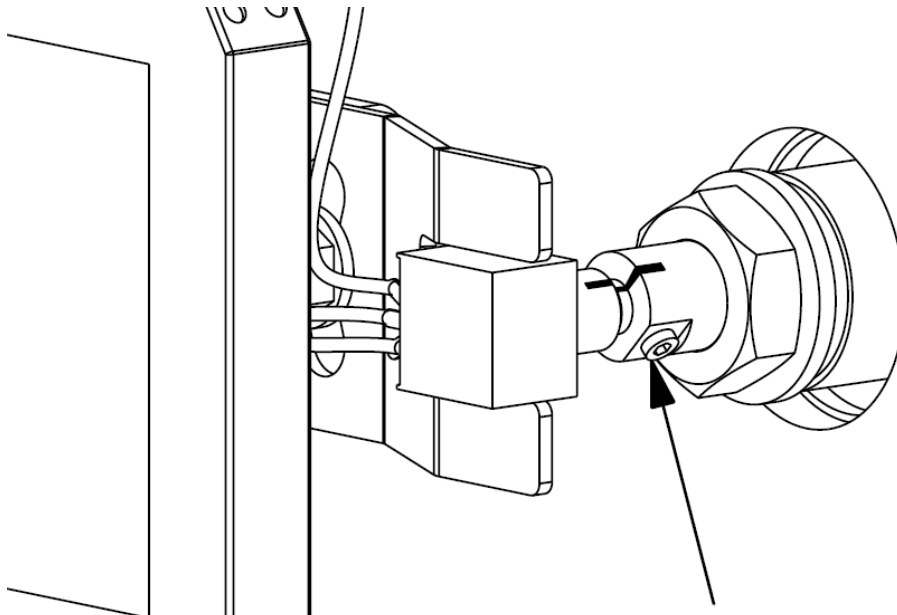

Figure 7-11: Removal of potentiometer

8. Loosen and remove the nut and washer from the sensor shaft.

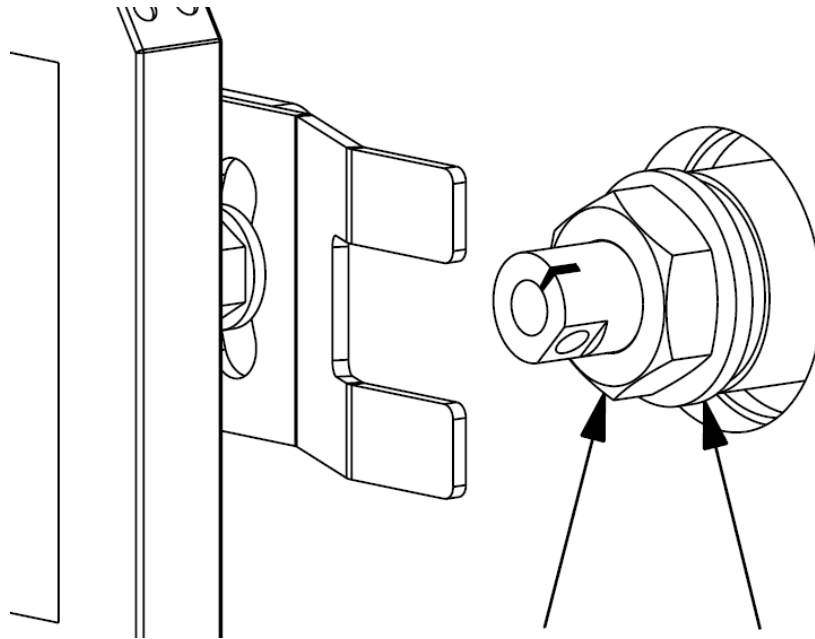

Figure 7-12: Sensor shaft fastener removal

9. Remove the cover of the counterweight enclosure.

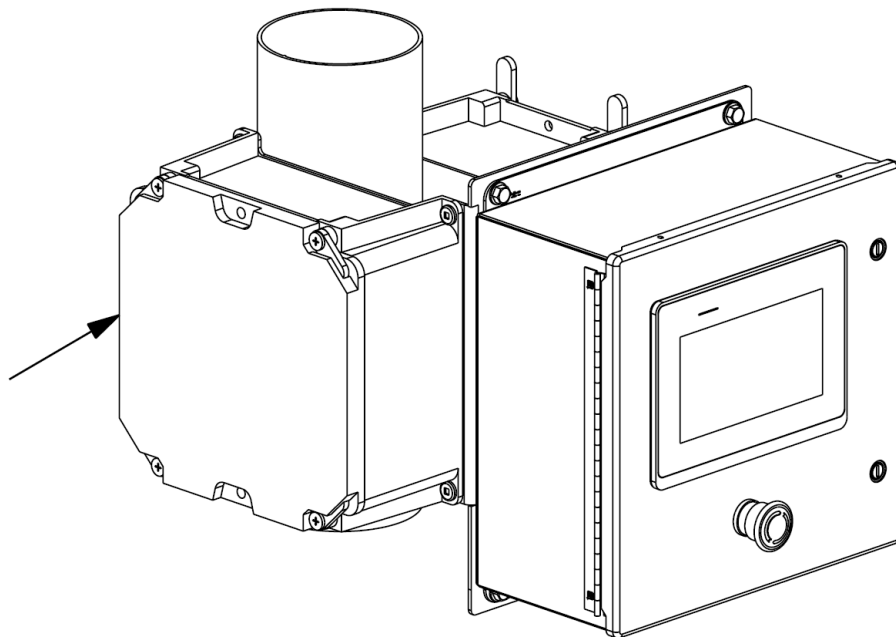

Figure 7-13: Counterweight enclosure cover

10. Loosen and remove the counterweight set screw and remove the counterweight from the sensor shaft.

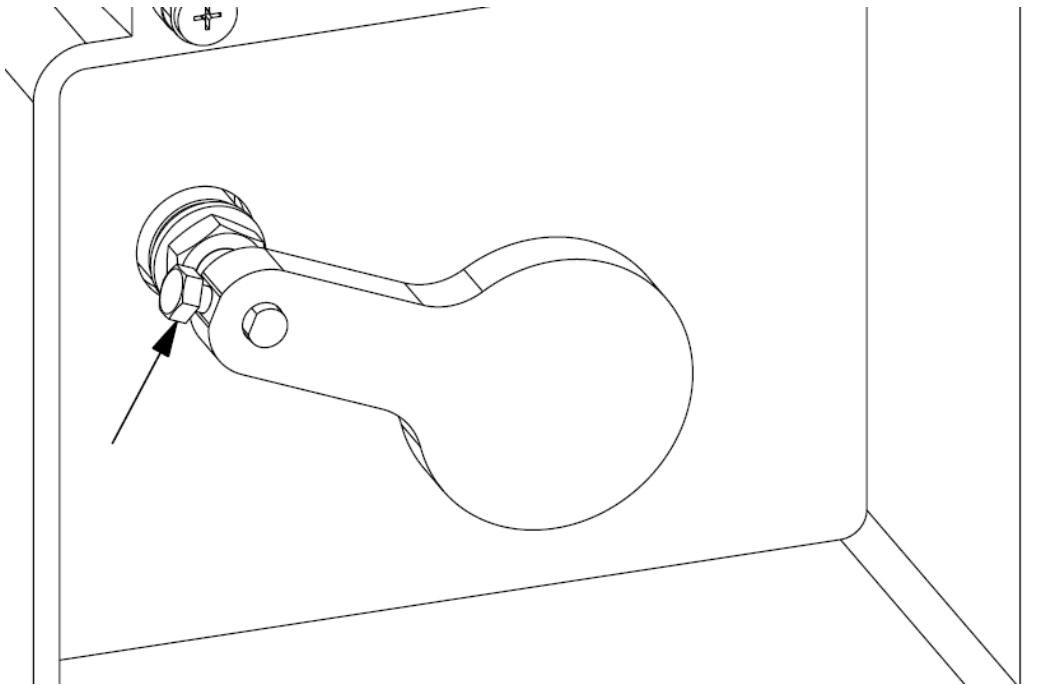

Figure 7-14: Counterweight and set screw removal

11. Loosen and remove the nut and washer from the sensor shaft.

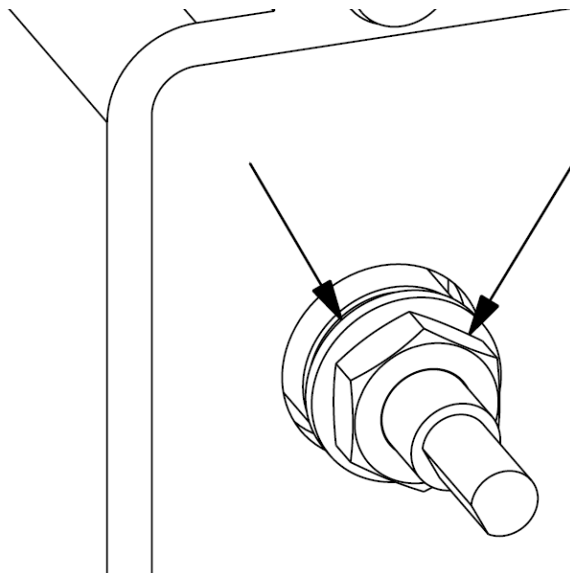

Figure 7-15: Sensor shaft fastener removal

12. Remove the two inner bushings from both ends of the sensor shaft.

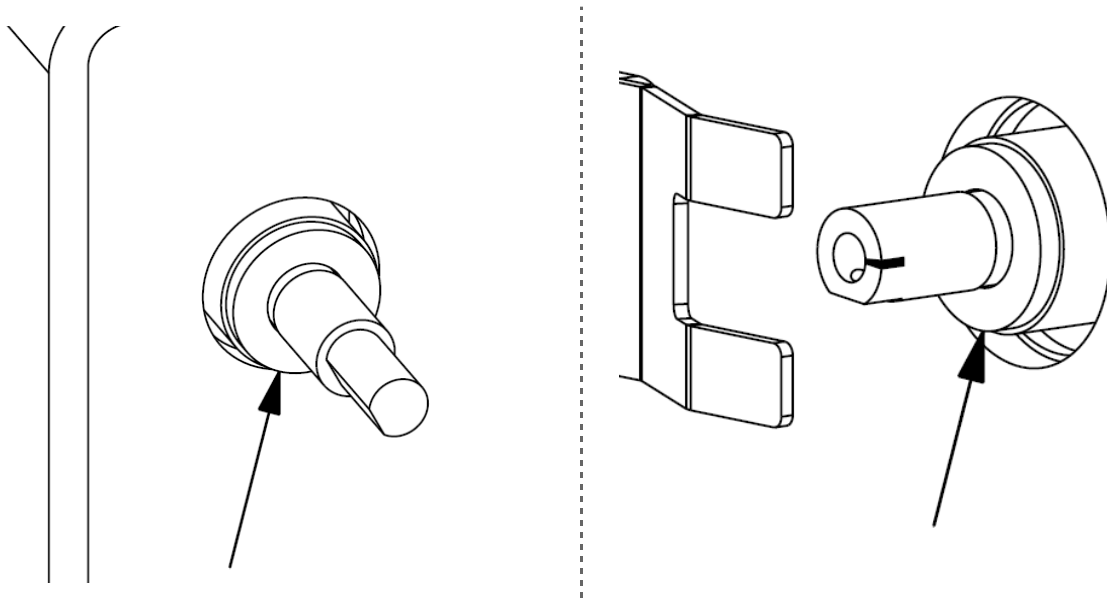

Figure 7-16: Inner bushing removal

13. Loosen the check valve set screws.

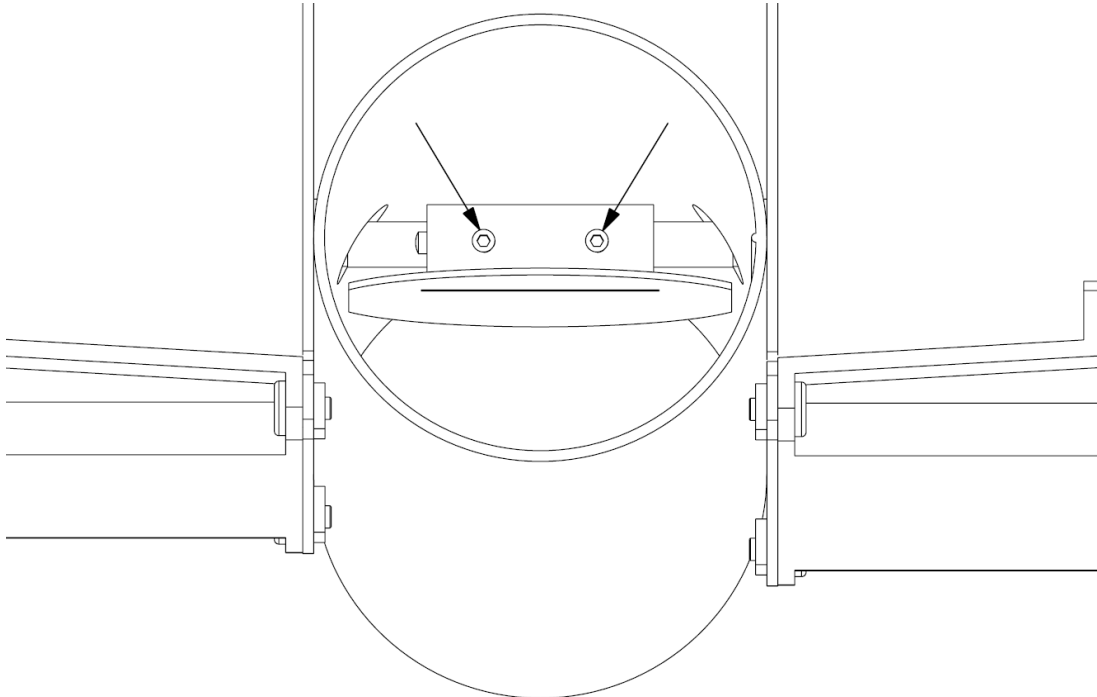

Figure 7-17: Check valve set screws

14. Reach into the air velocity sensor tube, through the top or bottom, and firmly grasp the check valve.
15. While holding the check valve to prevent fall damage, remove the sensor shaft through the counterweight enclosure, and then remove the sensor flap from the air velocity sensor tube. **Some portions of components have been removed for clarity.**

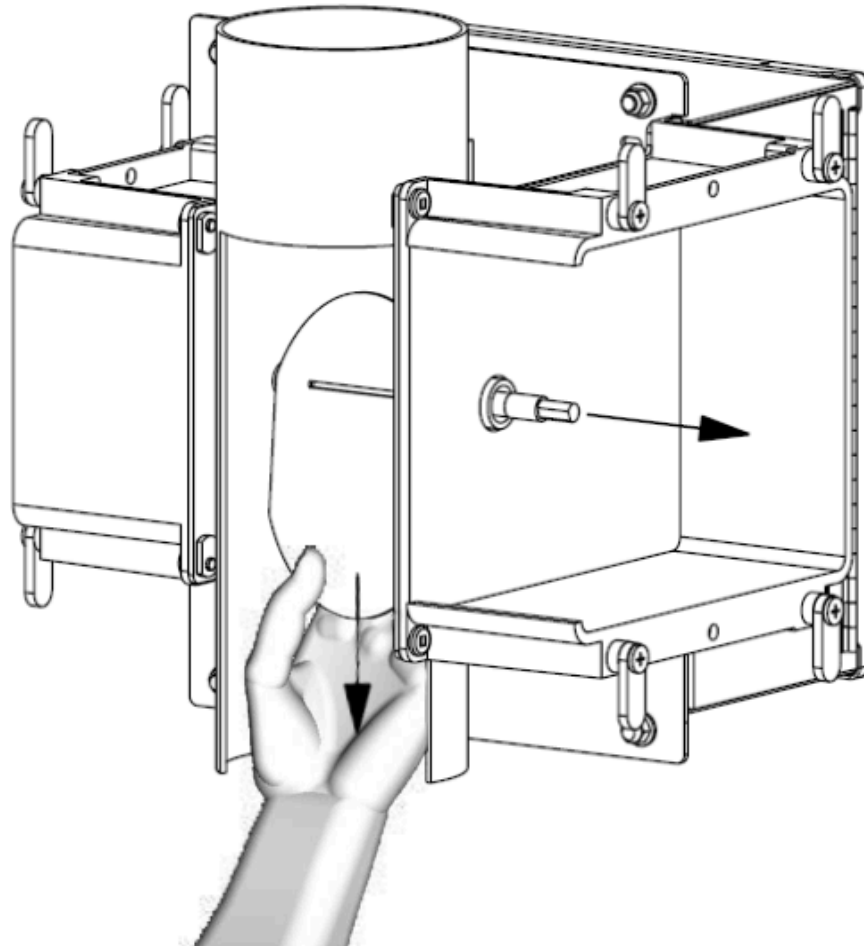

Figure 7-18: Sensor shaft and check valve removal

16. Inspect the interior surfaces of the air velocity sensor tube and outer bushings.
17. Blow out the interior surfaces to remove any dirt, dust or debris.
18. Inspect the removed components for dirt, dust or debris and clean as required.

19. If any dirt, dust or debris appears to be adhered to the interior surfaces or components, use water and a suitable solvent to dissolve any build-up. If required, any non-food-grade solvents must be cleaned from the components and surfaces using hot water and/or detergent. Ensure that any solvent used is acceptable for the intended market of the conveyed product.

NOTE: water and liquids can cause severe damage and catastrophic failure to electrical components, and personal injury. Do **NOT** allow water or any other liquid to come in contact with the control panel, signal conditioner, or any electrical components. Use extreme care when cleaning with water, solvents, detergents and any other liquids.

20. Ensure all components are clean and dry before reinstallation.
21. Insert the check valve into the air velocity sensor tube, positioned so the flap is pointed downwards towards the back of the air velocity sensor tube. Reference **Figure 7-18**.
22. While holding the check valve in position, carefully insert the sensor shaft through the counterweight enclosure.

NOTE: the sensor shaft is not symmetrical. Ensure the shaft end previously marked in *Step 7* is positioned within the signal conditioner enclosure. The flat surface at the center of the shaft for the check valve set screws should be angled towards the top of the air velocity sensor tube.

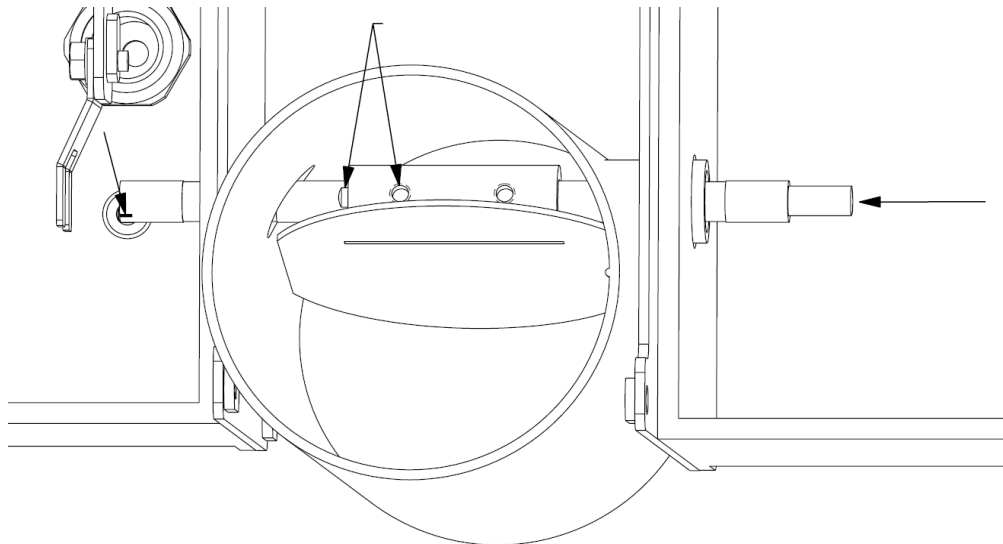

Figure 7-19: Sensor shaft positioning

23. Secure the check valve in place by tightening the set screws. Reference **Figure 7-17**.
24. Insert both inner bushings into the outer bushings of both enclosures. Reference **Figure 7-16**.
25. Install the washer and nut on the sensor shaft in the counterweight enclosure. Reference **Figure 7-15**.

26. Install the counterweight on the shaft aligning the flat surface of the shaft with the flat surface of the counterweight where the set screw is inserted.

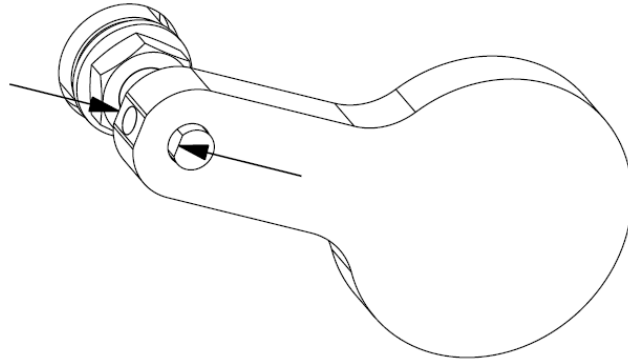

Figure 7-20: Counterweight alignment

27. Install the counterweight set screw and secure it in place. Reference **Figure 7-14**.
28. Install the washer and nut on the sensor shaft in the signal conditioner enclosure. Reference **Figure 7-12**.
29. Position the potentiometer with the mounting bracket and insert the potentiometer into the end of the sensor shaft. Ensure the mark created in *Step 7* on the potentiometer and sensor shaft are aligned. Reference **Figure 7-10**.
30. Install the potentiometer set screw and secure it in place. Reference **Figure 7-11**.
31. Rotate the counterweight to ensure it has full range of motion and the shaft rotates freely.

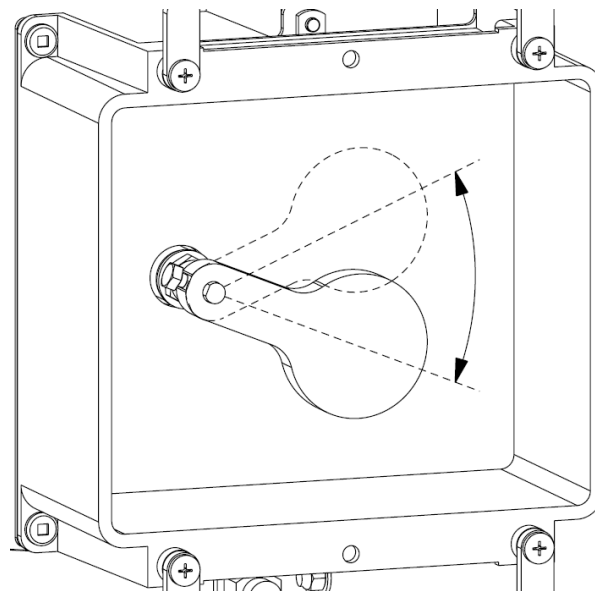

Figure 7-21: Counterweight range of motion

32. Install and secure the counterweight and signal conditioner enclosure covers. Reference **Figure 7-13** and **Figure 7-9**.
33. Refer to the auxiliary equipment's operator's manual to complete any required cleaning or preparations for the auxiliary equipment.
34. Refer to the *Assembly* sub-section of **Section 5: Machine Life-Cycle Procedures** to remount the Smart-Flo system to the blower package and any other previously removed components and assemblies.
35. Ensure all guards are installed and secured.
36. Ensure the system has been recalibrated to account for any slight discrepancies in the positioning of the potentiometer in relation to the sensor shaft.

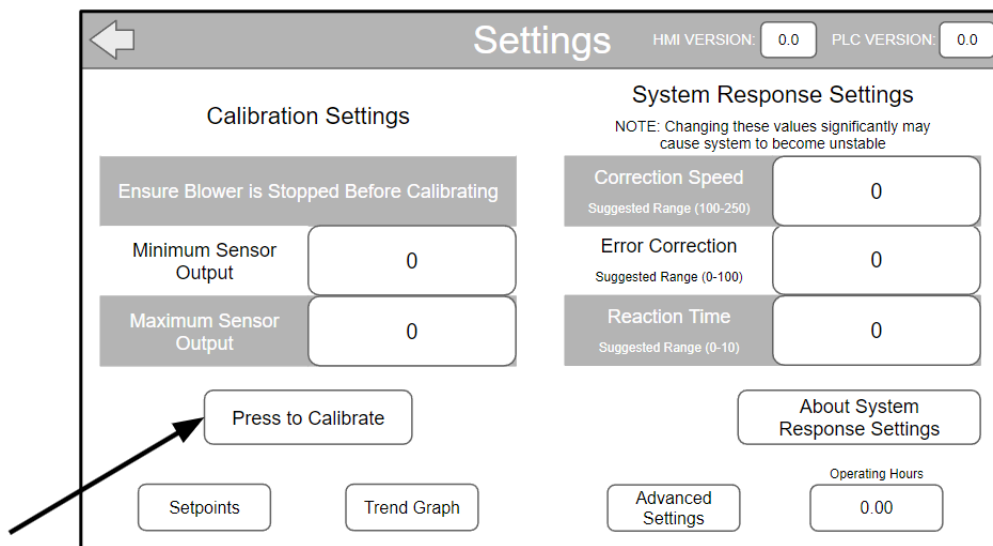

Figure 7-22: Air velocity sensor calibration

Inspection of Airlines

To maintain proper function of the air velocity sensor, and efficient operation of the Smart-Flo system, the airlines of the system must remain well sealed.

To inspect the condition of the airlines, proceed as follows:

1. Clear the area of bystanders, especially small children.
2. Ensure the power sources for the control panel, blower, airlock and any auxiliary equipment have not been locked-out. If locked-out, identify the cause and retrieve the tag before engaging power.
3. Refer to **Section 6: Operation** to start the system and allow it to operate at an idle.
4. Inspect the airline joints of the Smart-Flo system to the auxiliary equipment, listening and feeling for any signs of air leaks.

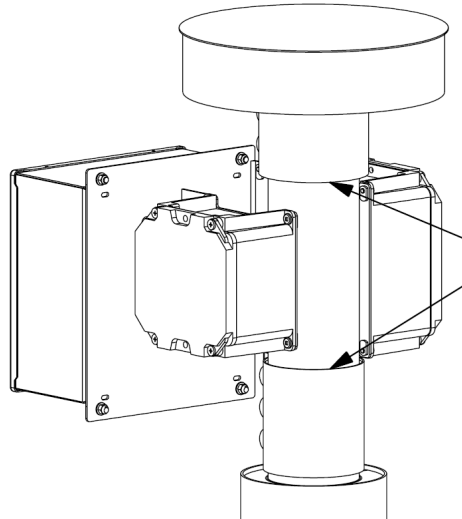

Figure 7-23: Airline joints

5. Shut down the system, and lock-out all power sources before adjusting, maintaining, cleaning, or replacing any components.
6. Ensure the compression couplings are fully tightened. Do not over-tighten compression couplings, as they may warp the air velocity sensor tube, inhibiting complete movement of the check valve and sensor shaft assembly.
7. Clean, repair or replace any dirty, worn, or damaged components as required to ensure the system is well sealed.
8. Refer to the auxiliary equipment's operator's manual to inspect the remaining airlines and seals of the system.
9. Ensure all guards are closed and secured.

ADJUSTMENTS

System Updates

As improvements are made to the Smart-Flo system, updates may become available to add features, keep systems up to date, or improve performance. System updates are broken down into firmware updates, PLC program updates, and HMI program updates. The firmware of the PLC must be updated before any program updates are installed.

To update the Smart-Flo system, proceed as follows:

1. Clear the area of bystanders, especially small children.
2. Updating the HMI and PLC programs may revert the system back to factory settings. Take note of any user settings before updating. Refer to **Section 5: Machine Life-Cycle Procedures** to re-establish any communication settings that may be reset after updating the PLC.
3. Disconnect and lock-out all power sources to external devices including the blower, airlock, any external automation systems, dryer, and any other equipment in the system.
4. Ensure the updates are stored on a smaller memory size external drive to ensure the updates are properly formatted into the FAT32 format, as only this filing system can be read by the PLC and HMI. Drives in the range of 1 GB to 8 GB are preferred.
5. To update the firmware of the PLC, proceed as follows:
 - a. Ensure the firmware update is saved on an SD card.
 - b. Turn off the power to the PLC.
 - c. Remove the cover from the PLC to gain access to the SD card port.

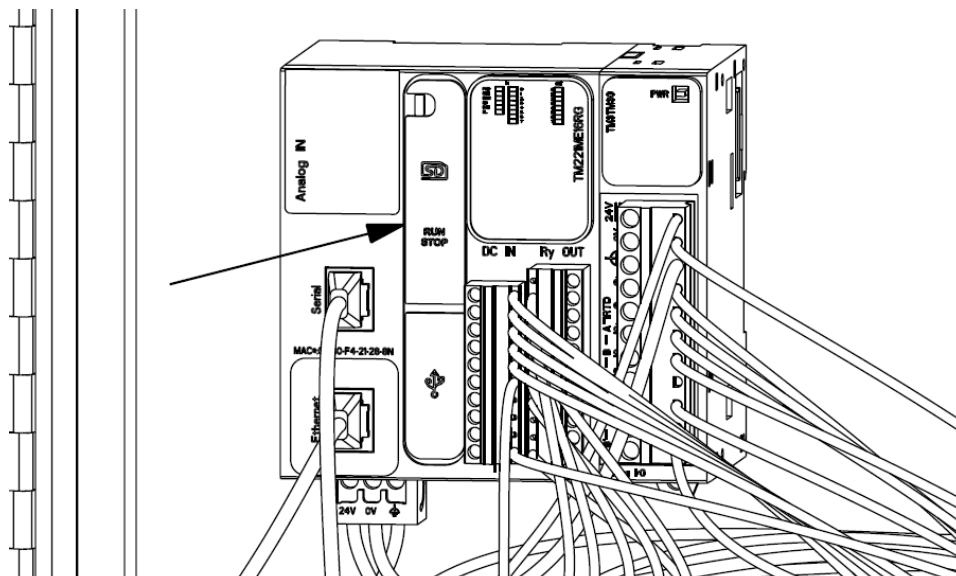

Figure 7-24: PLC port cover

- d. Insert the SD card with the firmware update into the PLC's port, it should click into place when fully inserted.

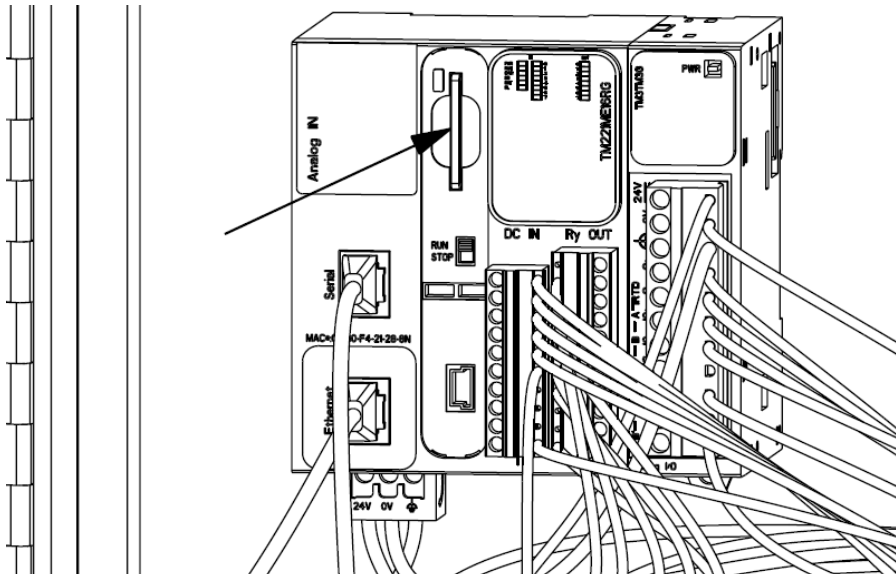

Figure 7-25: Insertion of SD card

- e. Turn on the power to the PLC.
- f. Ensure the PWR, ERR, and SD LEDs are illuminated.

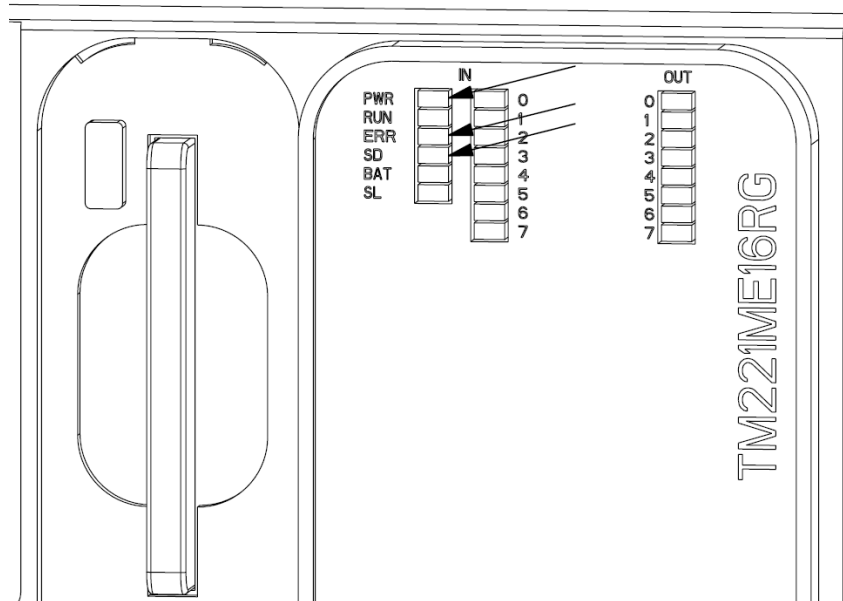

Figure 7-26: Initial LED illumination

- g. Allow the update process to complete, this process should take around 25 seconds.
 - h. Upon completion, the SD LED will turn off, the PLC will reboot and start as configured in the user application. In the event there is no user application, the ERR LED will begin to blink.
 - i. Remove the SD card from the PLC.
6. To update the PLC program, proceed as follows:
- a. Ensure the PLC program update is saved on an SD card.
 - b. Turn off the power to the PLC.
 - c. If not previously removed, remove the cover from the PLC to gain access to the SD card port. Reference **Figure 7-24**.
 - d. Insert the SD card with the PLC program update into the PLC's port, it should click into place when fully inserted. Reference **Figure 7-25**.
 - e. Turn on power to the PLC, the ERR LED will be illuminated.

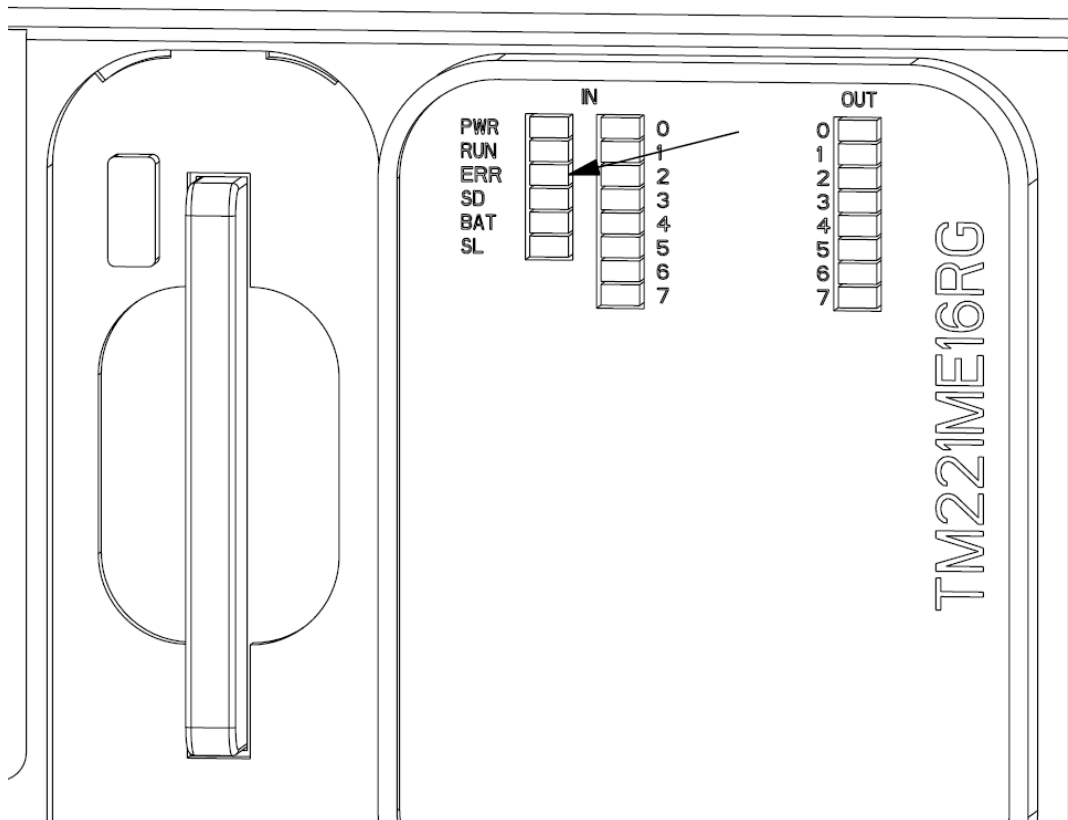

Figure 7-27: ERR LED illumination

- f. Allow the update process to complete.
- g. Upon successful completion, the SD LED will turn off. If the SD LED blinks, the update was unsuccessful. Repeat *Step 6a* through *Step 6e* to successfully update the PLC program. If the update is still unsuccessful, contact your local Walinga authorized service provider.
- h. Remove the SD card from the PLC, the ERR LED will turn off.
- i. Toggle the position of the *RUN/STOP* switch of the PLC from the *RUN* position to the *STOP* position and then back to the *RUN* position.

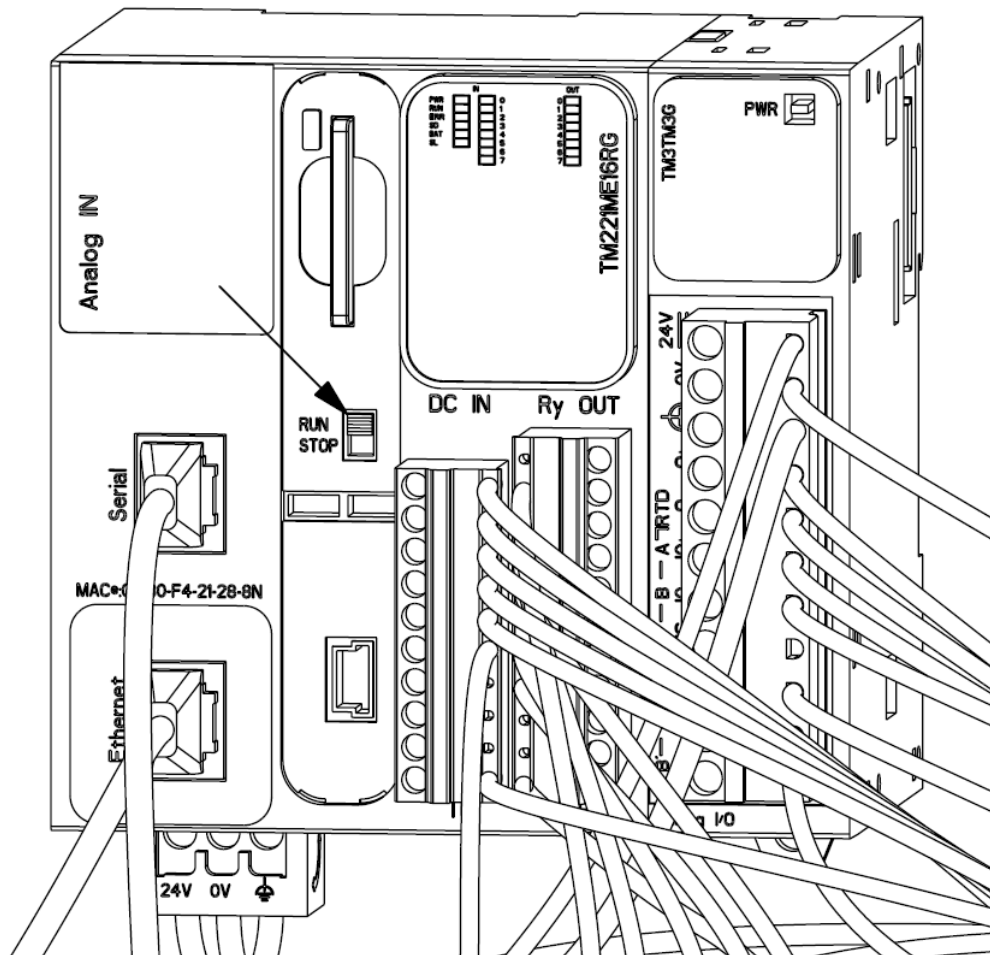

Figure 7-28: RUN/STOP switch

- j. For verification of a successful update, the SD card may be inserted into a computer. Open the "Script.log" using Notepad to view the log of the program transfer to the PLC. Upon successful update, the file will display "Returned OK" next to each action that was performed.

7. To update the HMI program, proceed as follows:
 - a. Ensure the HMI program update is saved on a USB drive.
 - b. Turn on the power to the HMI.
 - c. Insert the USB drive into the port on the HMI.

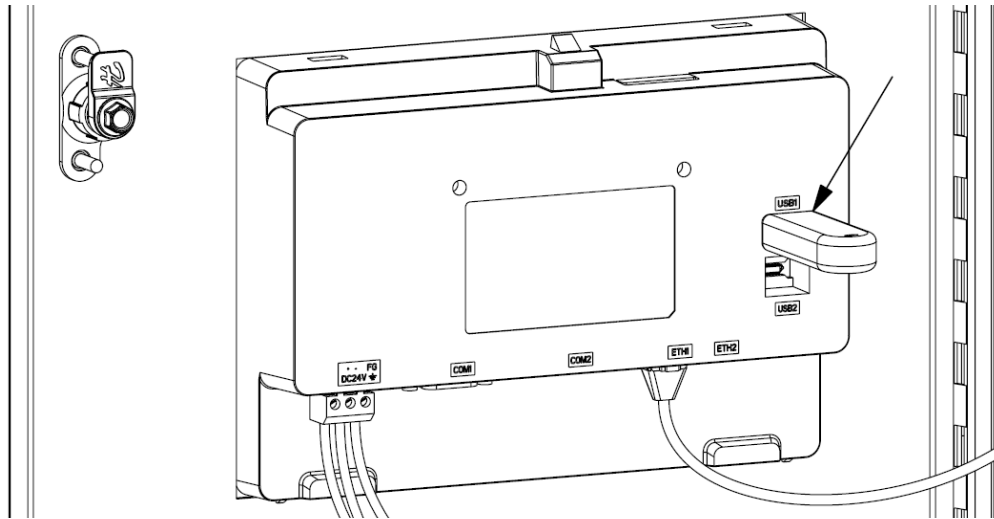

Figure 7-29: USB drive insertion

- d. Navigate to the Hardware Configuration screen on the HMI from the Advanced Settings screen.

Advanced Settings				FACTORY RESET (HOLD FOR 5 SECS)	
Setpoint Multiplier	OFF	Speed Setpoint	0.00 %	Pressure Sensor?	ON
Setpoint Multiplier Value	0	Flow Rate (%)	0.00 %	Dryer Vac?	OFF
KP Gain (x100)	0	Unscaled Flow Sensor Value	4197	Dryer Vac Setpoint	0.0 %
Ti Time (x0.1s)	0	Max Pressure Sensor Range (0-? PSI)	15	Over Pressure Delay	0 s
Td Time (x0.1s)	0	Max Pressure (PSI)	0	Airlock Start Delay	0 s
PID Output to Motor	0	Pressure Sensor Value	0	Blower Stop Delay	0 s
Stable Range	0	Idle Zone	0	Capacity Compensation	0
PID Status		Communication Setup		Hardware Configuration	

Figure 7-30: Advanced Settings screen

- e. Navigate to *Ethernet1* and ensure the IP address is **192.168.0.20** if the displayed address is different, it must be changed to the correct address to allow communication between the HMI and PLC.

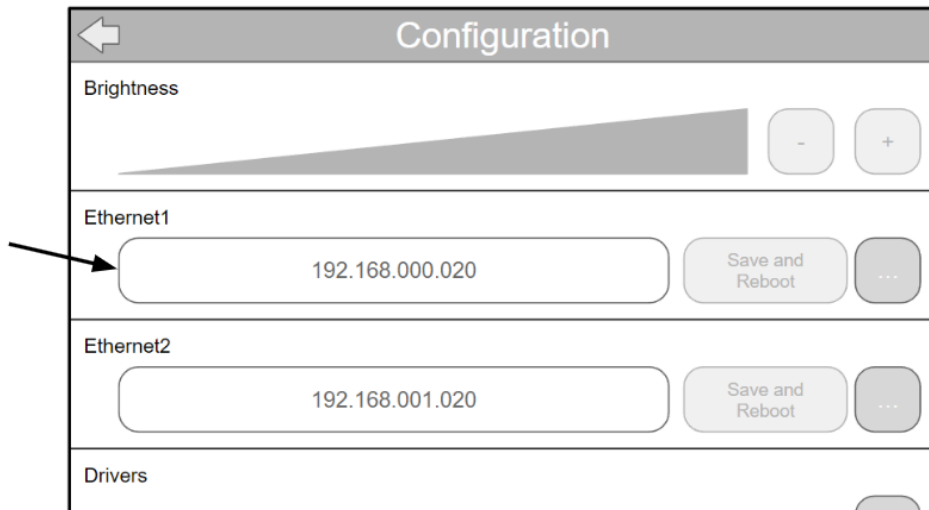

Figure 7-31: Ethernet1 IP address

- f. Navigate to *Download from* and select *USB* to begin the program update. The HMI screen should display “Downloading Now”.

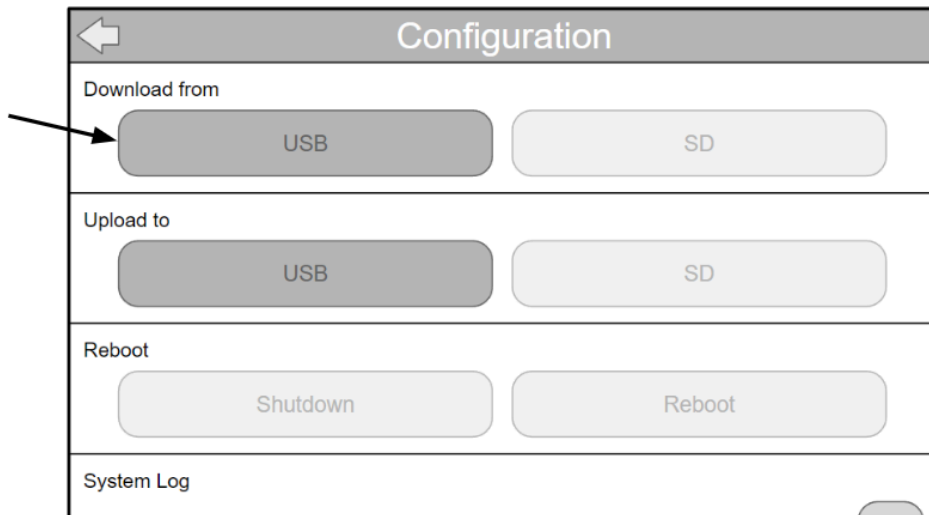

Figure 7-32: USB program update download initiation

- g. Allow the update process to complete.
 - h. Upon completion, the HMI screen will reboot and return to the Home Screen.
 - i. Remove the USB drive.
8. Navigate to the Settings screen on the HMI to verify both the HMI and PLC programs have been updated to the correct version.

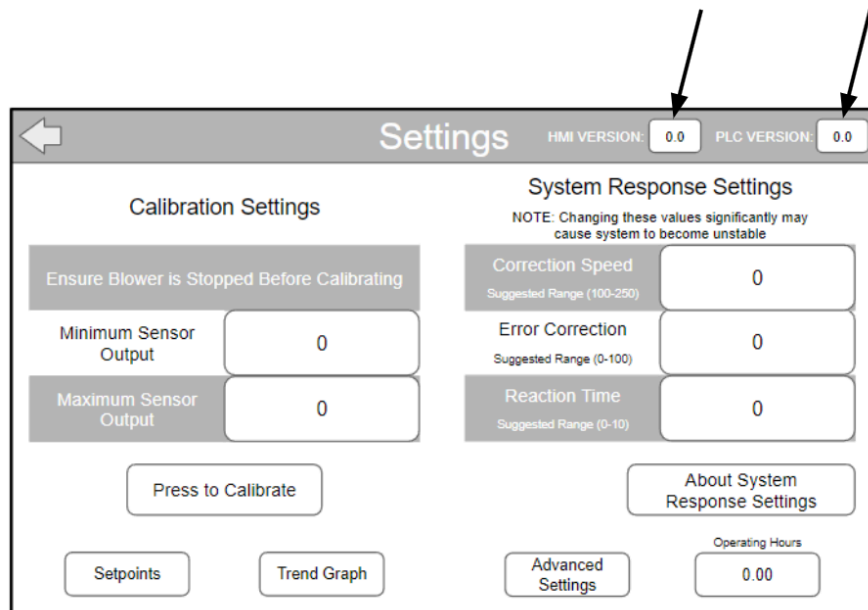

Figure 7-33: Verification of program versions

9. Upon successful updates to the PLC and HMI, review any user settings to ensure they are correct and as desired, as previously recorded in *Step 2*. If necessary, refer to **Section 5: Machine Life-Cycle Procedures** to re-establish any required settings.



Specifications

SMART-FLO 2.0 SYSTEM

TECHNICAL DATA

Table 8-1: Smart-Flo model dimensions

Model	Diameter (D)	Height (H)	Width (W)	Length (L)	Weight
2"	2.0 in (5.1 cm)	18.4 in (46.7 cm)	17.2 in (43.7 cm)	16.3 in (41.4 cm)	49.1 lbs (22.3 kg)
3"	3.0 in (7.6 cm)	18.4 in (46.7 cm)	17.2 in (43.7 cm)	16.3 in (41.4 cm)	52.7 lbs (23.9 kg)
4"	4.0 in (10.2 cm)	18.4 in (46.7 cm)	17.2 in (43.7 cm)	16.5 in (41.9 cm)	56.5 lbs (25.6 kg)
5"	5.0 in (12.7 cm)	18.4 in (46.7 cm)	17.2 in (43.7 cm)	17.3 in (43.9 cm)	59.8 lbs (27.1 kg)
6"	6.0 in (15.2 cm)	17.9 in (45.5 cm)	17.2 in (43.7 cm)	18.0 in (45.7 cm)	63.6 lbs (28.8 kg)
7"	7.0 in (17.8 cm)	22.0 in (55.9 cm)	17.2 in (43.7 cm)	18.8 in (47.8 cm)	73.7 lbs (33.4 kg)
8"	8.0 in (20.3 cm)	19.8 in (50.3 cm)	18.2 in (46.2 cm)	19.5 in (49.5 cm)	77.2 lbs (35.0 kg)

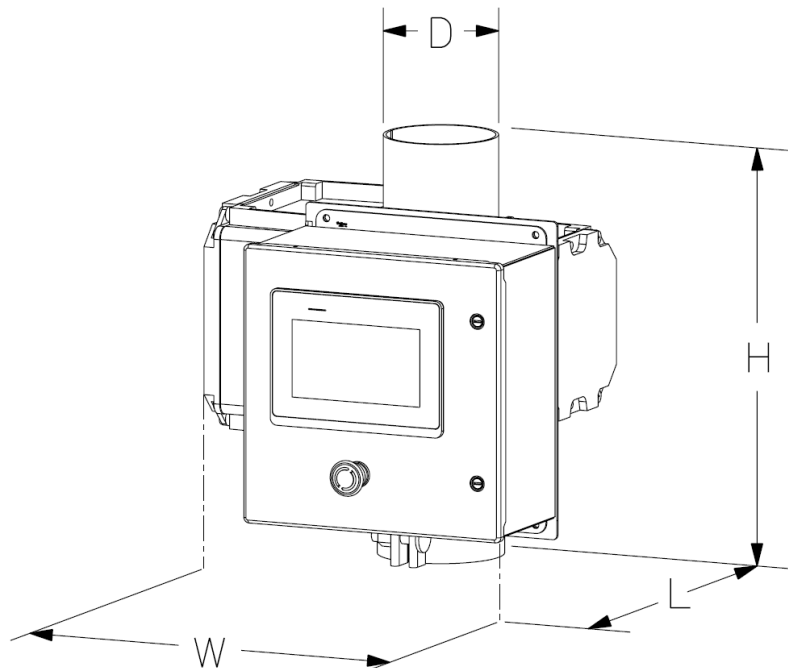

Figure 8-1: Model reference dimensions

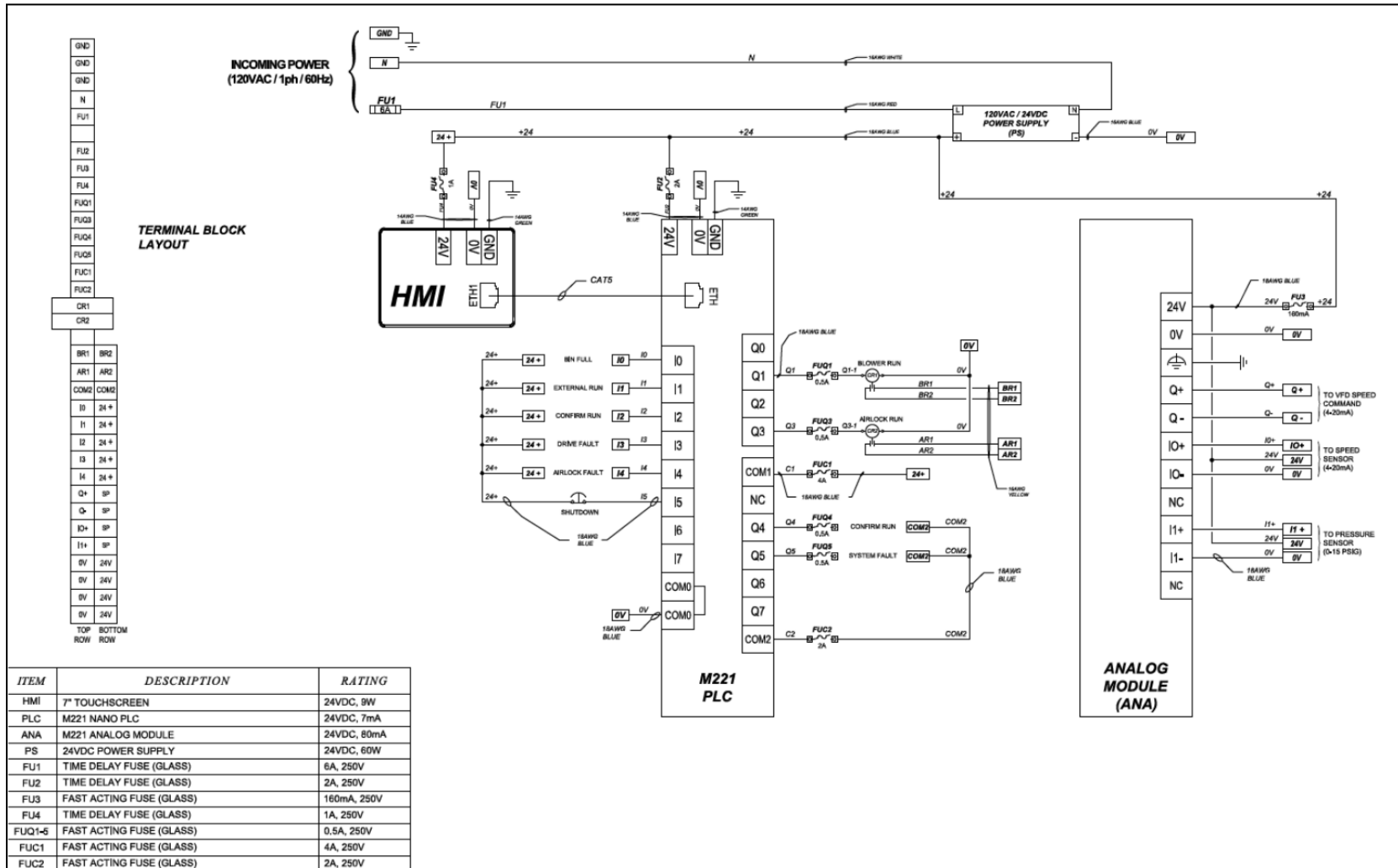

Figure 8-2: Smart-Flo control panel wiring diagram

BOLT TORQUES

The torque values for imperial and metric bolts and cap screws are given below in **Table 8-4** and **Table 8-5** respectively. Unless otherwise noted, tighten all bolts to the torque specified in the tables below. Check the tightness of the fasteners periodically. Replace any damaged or lost hardware with one of the same strength.

Torque values indicated in the following tables are valid for non-greased or non-oiled threads and heads. Unless otherwise specified, do not grease or oil any fasteners. When using locking elements, increase the listed torque values by 5%. Reference **Figure 8-3** and **Figure 8-4** for proper identification of grades.

Table 8-4: Imperial torque specifications

Bolt Diameter "A" [in]	Bolt Torque					
	SAE 2		SAE 5		SAE 8	
	[Nm]	[lb-ft]	[Nm]	[lb-ft]	[Nm]	[lb-ft]
1/4	8	6	12	9	17	12
5/16	13	10	25	19	36	27
3/8	27	20	45	33	63	45
7/16	41	30	72	53	100	75
1/2	61	45	110	80	155	115
9/16	95	60	155	115	220	165
5/8	128	95	215	160	305	220
3/4	225	165	390	290	540	400
7/8	230	170	570	420	880	650
1	345	225	850	630	1320	970

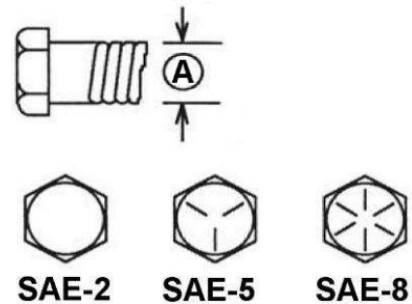

Figure 8-3: Imperial bolts

Table 8-5: Metric torque specifications

Bolt Diameter "A"	Bolt Torque			
	8.8		10.9	
	[Nm]	[lb-ft]	[Nm]	[lb-ft]
M3	.5	.4	1.8	1.3
M4	3	2.2	4.5	3.3
M5	6	4	9	7
M6	10	7	15	11
M8	25	18	35	26
M10	50	37	70	52
M12	90	66	125	92
M14	140	103	200	148
M16	225	166	310	229
M20	435	321	610	450
M24	750	553	1050	774
M30	1495	1103	2100	1550
M36	2600	1917	3675	2710

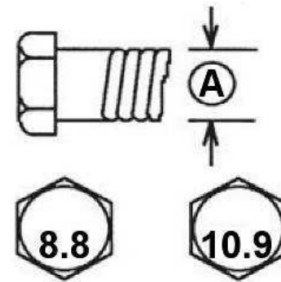

Figure 8-4: Metric bolts

STANDARDS AND REGULATIONS

Walinga follows the general safety standards specified by the American Society of Agricultural Engineers (ASAE) and the Occupational Safety and Health Administration (OSHA) with consideration of standards outlined by the National Fire Prevention Agency (NFPA), International Organization for Standardization (ISO), Occupational Health and Safety Standards (OH&S), and American National Standards Institute (ANSI). Be aware that there may be additional local or federal laws and regulations that require compliance based on operational location that are the responsibility of the owner and/or operator. For your convenience, the standards referenced in this manual and pertinent to the Smart-Flo system are listed below.

NFPA 70

National Electric Code

NFPA 652

Standard on the Fundamentals of Combustible Dust

ISO 4254-1

Agricultural Machinery - Safety - Part 1: General Requirements



Warranty

AFTERMARKET PARTS AND SERVICE

Walinga Inc. is committed to providing a quality product that will meet or exceed expectations for many years to come. The warranty terms and warranty claim process have been designed to ensure that each warranty claim will be resolved in an orderly, fair and timely manner.

THE WARRANTY

Walinga Inc. (“Walinga”) warrants that all new pneumatic products sold by Walinga will be free from defects in material and workmanship (the “Walinga Warranty”).

WARRANTY PERIOD

The warranty period for Walinga parts shall expire six (6) months after the date of sale to the original customer; with the exception of parts purchased from a Walinga authorized dealer. In these situations, the warranty period shall expire six (6) months after the date of sale recorded on the dealer’s Sales Order to their customer.

Parts which are purchased from Walinga and installed at a Walinga service facility, a Walinga authorized dealer, or a Walinga authorized service facility will qualify for a six (6) month warranty extension; bringing the total warranty period for these items to one (1) year from the date of their installation.

The warranty period for Walinga blowers and airlocks shall expire twelve (12) months after the date of sale to the original customer.

LIMITATIONS AND EXCLUSIONS OF THE WALINGA WARRANTY

- The Walinga Warranty applies to material and workmanship only.
- With respect to any component parts that are supplied or manufactured by others, the warranty coverage on such component parts will be strictly limited to the warranties of the manufacturers of such component parts.
- The Walinga Warranty shall only be for the benefit of the original purchaser of the aftermarket parts and service.
- A Walinga Warranty may be transferable by the original purchaser to a third party for the balance of the warranty period then remaining, provided that Walinga consents in writing to such a transfer of warranty.
- The Walinga Warranty is conditional upon proper storage, installation, use, maintenance, operation, and compliance with any applicable recommendations of Walinga.

WARRANTY CLAIM PROCEDURE

Should any difficulties with a unit within its warranty period be encountered, please contact a local Walinga dealer or sales representative, the local Walinga Service Department or Walinga’s Warranty Department to submit a warranty claim application.

To speak with a Walinga Warranty Coordinator, contact:

Canada and International	1-888-WALINGA (ext 273)	USA	1-800-466-1197 (ext 8)
	+1-519-824-8520 (ext 273)		warranty.usa@walinga.com
	warranty.canada@walinga.com	Australia	07-4634-7344
			mail@customvac.com.au

REQUIRED WARRANTY CLAIM INFORMATION

The following information must be provided to Walinga for proper consideration and processing of a warranty application:

- Customer name and contact information, including email if available
- The original Sales Order number and Vehicle Identification Number (VIN), if applicable
- Date of claimed failure
- Details, description and photos (upon request) of the claimed failure and the corrective repairs attempted

WARRANTY CONDITIONS

- Parts Warranty term begins on the date of purchase by the original purchaser; with the exception of items purchased from a Walinga authorized dealer, in which case the warranty period will begin on the purchase date recorded on the dealer's Sales Order to their customer.
- The buyer is responsible for promptly notifying Walinga of any defects to the parts to the parts or workmanship, and making the equipment available to Walinga or its authorized facility for evaluation or repair.
- Prior to making any repairs or parts replacements, a warranty application and any estimated associated costs must be approved with the issuance of a claim number by an authorized Walinga representative. Undertaking any work prior or part replacement prior to receiving warranty authorization may result in a partial or complete loss of warranty coverage.
- Walinga is not responsible for the cost of labor associated with part removal or installation performed by the customer or service providers other than Authorized Dealers and Service Centers or the costs of parts and labor associated with the repair or replacement of parts resulting from the use of non-Walinga approved parts and/or parts that do not meet Walinga specifications.
- At Walinga's request, parts in question must be returned to the nearest Walinga service facility for evaluation. In such situations, a Returned Goods Authorization (RGA) number will be provided to the customer. The returning shipment must be clearly labeled with the assigned RGA number and include a copy of the RGA form. Unless otherwise arranged, these parts are to be returned to Walinga within thirty (30) days to ensure timely processing of the warranty claim. Failure to return such parts may result in partial or complete loss of warranty coverage.
- Replacement parts provided under warranty are covered for the remainder of the original purchased parts or service warranty period.
- Walinga reserves the right to use new, remanufactured or refurbished components when performing warranty repairs and replacements.
- Walinga is entitled to a reasonable amount of time and a reasonable number of attempts to assess the claim, diagnose the problem, and perform any necessary repairs.
- The warranty offered on used or refurbished parts is limited to that specified on the Sales Order. Where a warranty period has not been stipulated on the purchase contract, such equipment is considered to be sold "as is, where is".

WARRANTY CLAIM REJECTION

Without limitation, Walinga reserves the right to reject a warranty claim for any one or more of the following reasons:

- The warranty claim information provided is insufficient.
- The product evaluation does not substantiate the claim.
- The unit has been operated above and beyond its capacity or not maintained or serviced properly, resulting in damages incurred to major components.
- It is apparent that the operator's manuals have not been followed.

NOT COVERED UNDER WARRANTY

Without limitation, the Walinga Warranty does not cover:

- Damage or deterioration due to lack of reasonable care or maintenance.
- Damage caused or affected by unapproved modifications to the equipment.
- Damage caused by negligence or misuse of the equipment.
- Damage caused by improper repair of equipment or incorrect installation of components.
- Damage caused by using the equipment for purposes for which it was not designed or intended.

Walinga's liability under this warranty, whether in contract or tort, is limited to the repair, replacement or adjustment of defective materials and workmanship. In no event will Walinga be responsible for any direct, indirect, loss of time, incidental or consequential expenses including, but not limited to equipment rental expenses, towing, downtime, inconvenience, or any losses resulting from the inability to use the equipment. Further, Walinga shall not be liable for any damages or inconvenience caused by any delay in the supply of any equipment or component parts thereof.

The selling dealer/salesperson makes no warranty of its own and has no authority to make any representation or promise on behalf of Walinga, or to modify the terms or limitations of the Walinga Warranty in any way.

Punitive, exemplary or multiple damages may not be recovered unless applicable law prohibits their disclaimer.

Warranty related claims may not be brought forward as a class representative, a private attorney general, a member of a class of claimants or in any other representative capacity.

The Walinga Warranty and all questions regarding its enforceability and interpretation are governed by the law of the country, state or province in which the Walinga equipment was purchased. The laws of some jurisdictions limit or do not allow the disclaimer of consequential damages. If the laws of such a jurisdiction apply to any claim against Walinga, the limitations and disclaimers contained here shall be to the greatest extent permitted by law.



Accessories and Attachments

SMART-FLO 2.0 SYSTEM

Several accessories are available for use alongside a Smart-Flo system to improve the operational experience and system performance. Below are some of the available accessories and a general description of their function. Please contact your Walinga dealer or representative for accessories compatible with your specific system, availability and ordering, or if you have any questions.

PRESSURE SENSOR

To provide increased monitoring and control of blower speeds, a pressure sensor may be mounted on the outlet of the blower.

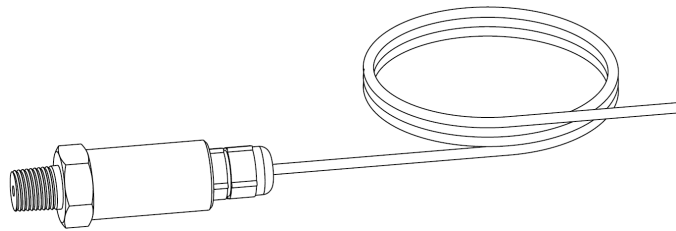

DRYER-VAC

Walinga's Dryer-Vac is only available for Ultra-Veyor systems equipped with a Smart-Flo 2.0 system to maintain proper control of the blower speeds to ensure the system operates at the full capacity.

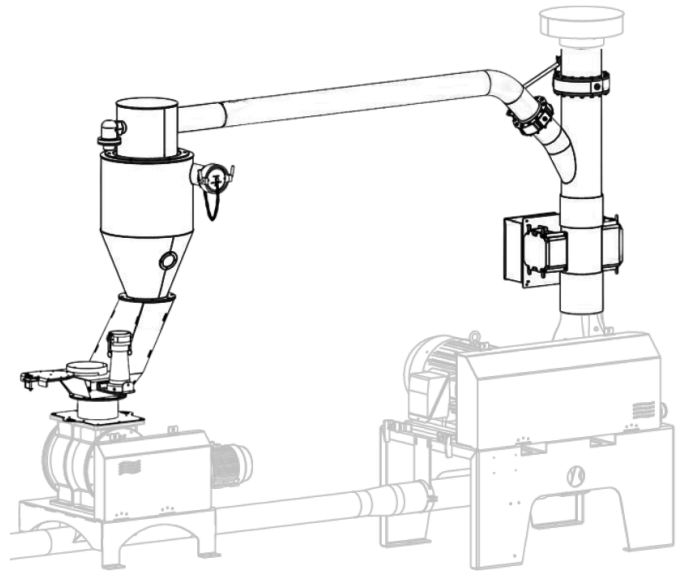



Parts List

SMART-FLO 2.0 SYSTEM

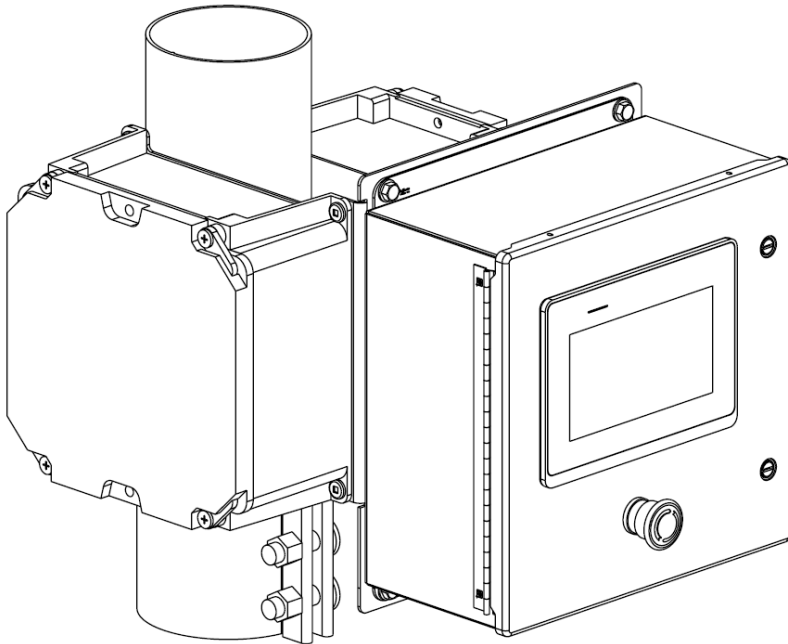
MODEL ASSEMBLIES

Description	Part Number
SMART-FLO KIT, 2"	11-115383-5
SMART-FLO KIT, 3"	11-115222-5
SMART-FLO KIT, 4"	11-115220-5
SMART-FLO KIT, 5"	11-99465-5
SMART-FLO KIT, 6"	11-99466-5
SMART-FLO KIT, 7"	11-115384-5
SMART-FLO KIT, 8"	11-99467-5

INDIVIDUAL COMPONENTS

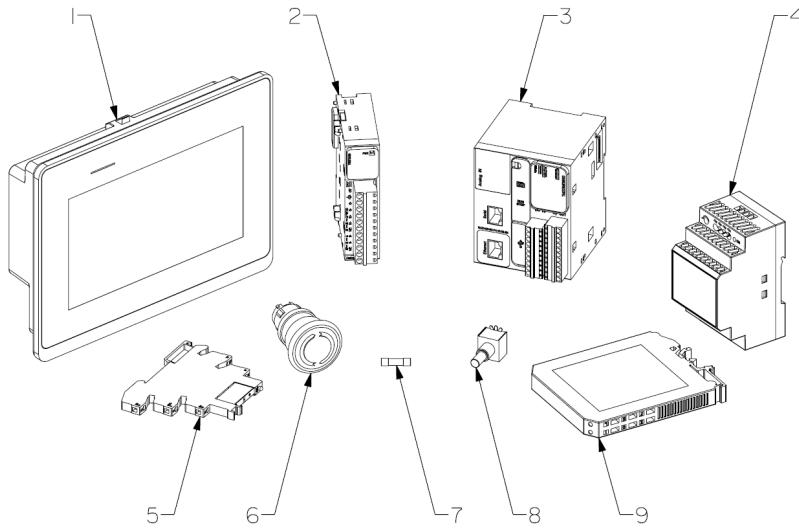

Ref.	Description	Part Number
1	HMI SCREEN, HMIST6400	11-153636-6
2	ANALOG MODULE, TM3TM3G	11-153813-6
3	PLC MODULE, TM221ME16RG	11-153812-6
4	POWER SUPPLY, DRCUS24	11-153815-6
5	CONTROL RELAY, RSL1PVBU	11-153816-6
6	EMERGENCY STOP, ZB4S844	11-153814-6
7	TIME DELAY FUSE, GLASS, 6A, 250V	82-145388-6
	TIME DELAY FUSE, GLASS, 2A, 250V	82-151503-6
	FAST ACTING FUSE, GLASS, 160mA, 250V	82-145393-6
	TIME DELAY FUSE, GLASS, 1A, 250V	82-145391-6
	FAST ACTING FUSE, GLASS, 0.5A, 250V	82-145392-6
	FAST ACTING FUSE, GLASS, 4A, 250V	82-145389-6
8	POTENTIOMETER, 657BR0103	11-87249-6
	SIGNAL CONDITIONER, DAT2105-2W	11-145698-6

For replacement of any component not listed, please contact your local Walinga dealer or representative and be prepared to provide the model size and serial number of your Smart-Flo system.



PAGE INTENTIONALLY LEFT BLANK



PAGE INTENTIONALLY LEFT BLANK

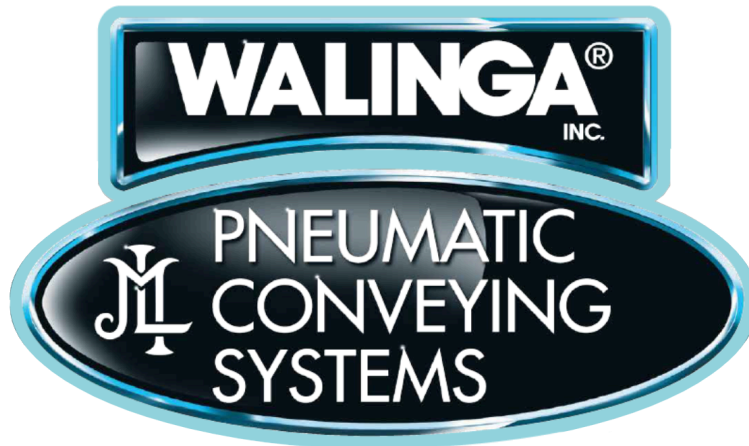

WALINGA[®]
INC.

CORPORATE HEAD OFFICE:

5656 Highway 6N
RR#5 Guelph, Ontario, N1H 6J2
PHONE (519) 824-8520
FAX (519) 824-5651
www.walinga.com

FACTORY DISTRIBUTION AND SERVICE CENTERS:

938 Glengarry Crescent
Fergus, ON, Canada, N1M 2W7
PHONE (519) 787-8227
FAX (519) 787-8210

70 3rd Avenue N.E. Box 1790
Carman, MB, Canada, R0G 0J0
PHONE (204) 745-2951
FAX (204) 745-6309

6116 46 St.
Bloomsbury, AB, Canada, T0G 0G0
PHONE (780) 572-6082

1190 Electric Avenue
Wayland, MI, USA, 49348
PHONE (800) 466-1197
FAX (616) 877-3474

579 4th St. NW
Sioux Center, IA, USA, 51250
PHONE (800) 845-5589
FAX (712) 722-1128

24 Molloy St.
Toowoomba, Qld, Australia, 4350
PHONE 07-4636-7344
EMAIL mail@customvac.com.au