



# OPERATOR'S MANUAL

## Blower 614

*English*

00-147756-0 A  
2025-09-08

**WALINGA®**  
**TOUGH TO BEAT IN THE LONG RUN**

---

## TO OUR VALUED CUSTOMERS:

The Walinga network of distribution centers and authorized dealers are dedicated to providing worldwide coverage of original parts and accessories for Walinga Pneumatic Conveying Systems. Our parts reflect Walinga's continued commitment to provide our customers with the highest quality parts and service.

For your convenience, should you require any information related to technical support, warranty, service, parts, or sales, please contact one of the following Walinga personnel:

### TECHNICAL SUPPORT

1-833-233-8227

pcs.techsupport@walinga.com

### WALINGA WARRANTY COORDINATORS

Canada and International  
USA  
Australia

1-888-WALINGA (ext 258)  
1-800-466-1197 (ext 8)  
07-4634-7344

warranty.canada@walinga.com  
warranty.usa@walinga.com  
mail@customvac.com.au

### SERVICE

Guelph, ON, Canada  
Carman, MB, Canada  
Barrhead, AB, Canada  
Wayland, MI, USA  
Sioux Center, IA, USA  
Toowoomba, QLD, Australia

1-888-WALINGA (ext 228)  
1-800-668-6344 (ext 418)  
1-780-572-6082 (ext 1001)  
1-800-466-1197 (ext 508)  
1-800-845-5589 (ext 804)  
07-4634-7344

guelph.service@walinga.com  
carman.service@walinga.com  
todd.swaving@walinga.com  
wayland.service@walinga.com  
siouxcenter.service@walinga.com  
mail@customvac.com.au

### ORIGINAL PARTS SALES

Eastern Canada and International  
Western Canada  
Eastern USA  
Western USA  
Australia

1-888-WALINGA (ext 224)  
1-800-668-6344 (ext 421)  
1-800-466-1197 (ext 507)  
1-800-845-5589 (ext 802)  
07-4634-7344

parts.canada@walinga.com  
parts.carman@walinga.com  
parts.usa@walinga.com  
parts.siouxcenter@walinga.com  
parts.australia@walinga.com

### SALES MANAGER

Tim Linde

1-519-787-8227 (ext 109)

tim.linde@walinga.com

### CORPORATE HEAD OFFICE

5656 Highway 6N  
RR#5, Guelph, Ontario, N1H 6J2  
Tel: 888-925-4642 Fax: 519-824-5651  
www.walinga.com

### FACTORY DISTRIBUTION AND SERVICE CENTERS

938 Glengarry Crescent, Fergus  
Ontario, Canada N1M 2W7  
Tel: 519-787-8227 Fax: 519-787-8210

1190 Electric Avenue, Wayland  
Michigan, USA 49348  
Tel: 800-466-1197 Fax: 616-877-3474

70 3rd Ave. NE Box 1790, Carman  
Manitoba, Canada R0G 0J0  
Tel: 204-745-2951 Fax: 204-745-6309

579 4th St. NW, Sioux Center  
Iowa, USA 51250  
Tel: 800-845-5589 Fax: 712-722-1128

6116 46 St., Barrhead  
Alberta, Canada T0G 0J0  
Tel: 780-572-6082

24 Molloy St., Toowoomba  
Queensland, Australia 4350  
Tel: 07-4634-7344 Email: mail@customvac.com.au

## Table of Contents

<b>Contact Information [00-145699-0]</b> - - - - -	<i>i</i>
<b>Table of Contents [00-145699-0]</b> - - - - -	<i>ii</i>
<b>Literature Information [00-145699-0]</b> - - - - -	<i>v</i>
<b>Identification of Machine [00-145699-0]</b> - - - - -	1-1
<i>Serial Numbers</i> - - - - -	1-2
<b>Introduction [00-145702-0]</b> - - - - -	2-1
<i>Statement of Importance</i> - - - - -	2-2
<i>Intended Use</i> - - - - -	2-2
<i>Directional References</i> - - - - -	2-3
<i>Blowers in Pneumatic Conveying Systems</i> - - - - -	2-3
<b>Machine Configuration [00-145703-0]</b> - - - - -	3-1
<i>Model Sizes</i> - - - - -	3-2
<i>Model Variations</i> - - - - -	3-3
<b>Safety [00-145704-0]</b> - - - - -	4-1
<i>Safety Alert Symbol</i> - - - - -	4-2
<i>Signal Words</i> - - - - -	4-2
<i>General Safety</i> - - - - -	4-3
<i>Installation Safety</i> - - - - -	4-5
<i>Storage Safety</i> - - - - -	4-5
<i>Pre-Operation Safety</i> - - - - -	4-5
<i>Operational Safety</i> - - - - -	4-6
<i>Maintenance Safety</i> - - - - -	4-7
<i>Machine Safety Signs</i> - - - - -	4-8
<i>Safety Training Sign-Off Form</i> - - - - -	4-13

---

<b>Machine Life-Cycle Procedures [00-145705-0]</b> .....	5-1
<i>Reception, Installation and Initial Set-Up</i> .....	5-2
<i>Reception</i> .....	5-2
<i>Installation</i> .....	5-3
<i>Initial Set-Up</i> .....	5-13
<i>Break-In Inspections</i> .....	5-14
<i>Storage</i> .....	5-16
<i>End of Life</i> .....	5-18
<b>Operation [00-145706-0]</b> .....	6-1
<i>Machine Features and Components</i> .....	6-2
<i>Controls and Displays</i> .....	6-4
<i>Operation</i> .....	6-4
<i>Pre-Operation Machine Preparation</i> .....	6-4
<i>Operation of the Machine</i> .....	6-5
<i>Stopping the Machine</i> .....	6-6
<i>Clearing Blockages</i> .....	6-7
<i>Operating Tips and Hints</i> .....	6-12
<i>Troubleshooting</i> .....	6-13
<b>Maintenance and Adjustments [00-145707-0]</b> .....	7-1
<i>Maintenance Schedule</i> .....	7-2
<i>Maintenance Safety</i> .....	7-3
<i>Complete Disassembly and Assembly Procedures</i> .....	7-3
<i>Maintenance Procedures</i> .....	7-44
<i>Maintenance Materials</i> .....	7-52
<i>Adjustments</i> .....	7-53
<i>Casing Clearances</i> .....	7-59
<i>End Clearances</i> .....	7-61
<i>Timing Clearances</i> .....	7-65

---

<b>Specifications [00-145708-0]</b> - - - - -	8-1
<i>Technical Data</i> - - - - -	8-2
<i>Bolt Torques</i> - - - - -	8-12
<i>Standards and Regulations</i> - - - - -	8-15
<b>Warranty [00-145861-0]</b> - - - - -	9-1
<i>The Warranty</i> - - - - -	9-2
<i>Warranty Period</i> - - - - -	9-2
<i>Limitations and Exclusions of the Walinga Warranty</i> - - - - -	9-2
<i>Warranty Claim Procedure</i> - - - - -	9-2
<i>Required Warranty Claim Information</i> - - - - -	9-3
<i>Warranty Conditions</i> - - - - -	9-3
<i>Warranty Claim Rejection</i> - - - - -	9-4
<i>Not Covered Under Warranty</i> - - - - -	9-4
<b>Accessories and Attachments [00-145710-0]</b> - - - - -	10-1
<b>Parts List [00-145712-0]</b> - - - - -	11-1
<i>Model References</i> - - - - -	11-2
<i>Casing and Impeller Components</i> - - - - -	11-3
<i>Headplate Components</i> - - - - -	11-4
<i>Drive End Components</i> - - - - -	11-5
<i>Idle End Components</i> - - - - -	11-6
<i>Cover Components</i> - - - - -	11-7
<i>Miscellaneous Components</i> - - - - -	11-8
<i>Assembly Tools</i> - - - - -	11-9

This manual contains important information regarding the safety, operation and maintenance of your Walinga blower.

Some illustrations and diagrams may show safety shields, guards, or covers removed for clarity. **DO NOT** operate the machine without these guards in place.

### **Identification of Machine**

The identification of machine section outlines the applicable models included in this manual. It identifies the location of the machine serial number and serialized components and provides space for recording these numbers.

### **Introduction**

The introduction section outlines the importance of this document and provides details for the interpretation and understanding of information presented in this manual.

### **Configuration**

The configuration section gives an overview of the various configurations available for the specified model and identification between the different configurations.

### **Safety**

The safety section lists important safety precautions and procedures as well as providing the meaning, location and visual representation of all safety signs and labels on the machine. Read and understand all precautions before operating, maintaining or transporting the machine.

### **Machine Life-Cycle Procedures**

The machine life-cycle procedures section provides information on the reception, assembly and initial set-up, storage, and end of life procedures.

### **Operation**

The operation section gives general information on the operating principles including starting, operating functions, stopping the machine, and clearing any blockages. This section also provides troubleshooting information for fault diagnosis and solutions to issues that may be encountered.

### **Maintenance and Adjustments**

The maintenance and adjustments section provides the recommended maintenance schedule and task instructions for both calendar and operation hour intervals, maintenance should be performed at the first occurrence of these two intervals.

### **Specifications**

The specifications section details technical data of the particular model to achieve a high standard of operational performance and outlines relevant standards and regulations.

### **Warranty**

The warranty section outlines the terms and limitations of the warranty coverage.

### **Accessories and Attachments**

The accessories and attachments section lists available attachments for the machine.

### **Parts List**

The parts list section provides information for the identification of replacement assemblies, subassemblies and parts.



# Identification of Machine

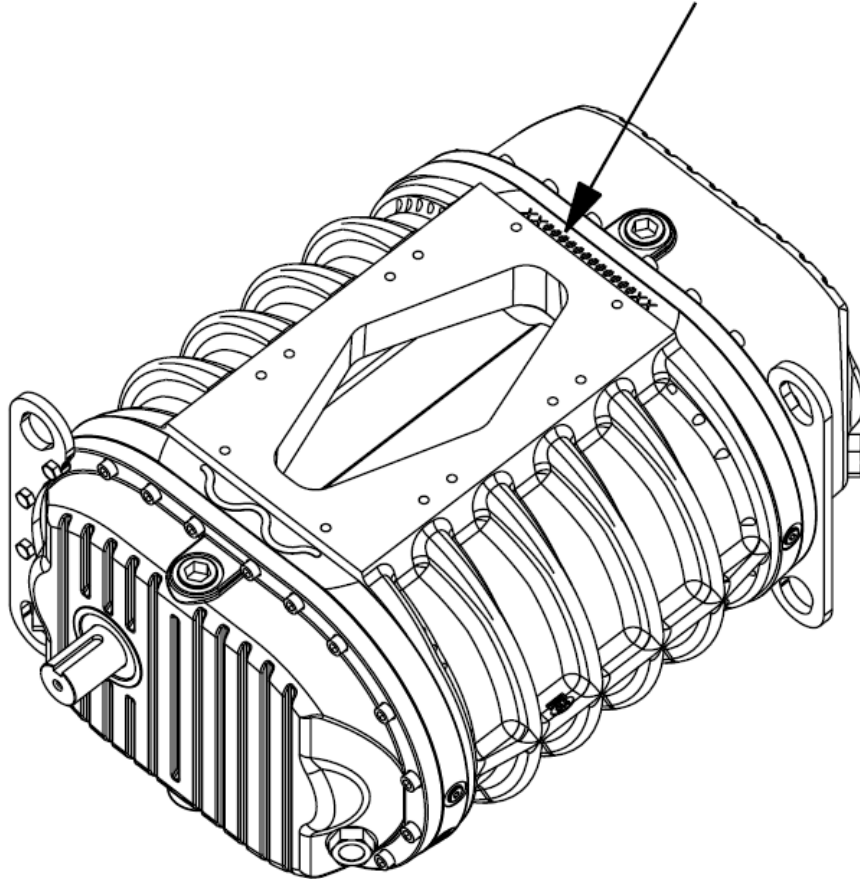
---

BLOWER 614 MODEL

---

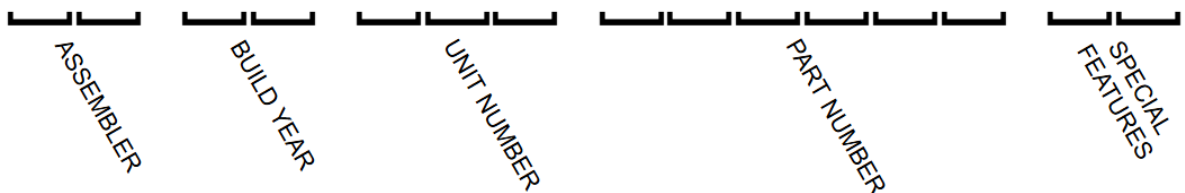
## SERIAL NUMBERS

Be prepared to provide the serial number of the blower to your Walinga dealer or representative when ordering parts or requesting service or other information. For easy reference, record the required serial number as follows:



### Blower Serial Number

Located on the top of the rear headplate of the blower





# Introduction

---

BLOWER MODELS

---

## STATEMENT OF IMPORTANCE

Congratulations on your choice of a Walinga blower to complement your operation. This equipment has been designed, engineered and manufactured to meet the needs of the discriminating buyer for the efficient moving of bulk commodities.

Your safety and the performance of your blower are Walinga's top priorities. This operator's manual has been created for the express purpose of keeping you safe and providing education for the efficient use of your blower.

Safe, efficient and trouble-free operation of your blower requires that you and any individuals operating or maintaining the machine, read and understand all sections of this operator's manual. An operator who has not familiarized themselves with the contents of this manual constitutes an untrained operator. Untrained operators are not qualified to operate the machine.

Keep this manual available for frequent reference and for provision to new operators or owners.

Your machine's appearance or structural design may differ from illustrations shown in the manual. Continuous design improvements for optimized field performance are on-going and may have been made to your machine since the publication of the manual. Specifications, descriptions and all other information in the manual are subject to change and/or correction without notice. Contact your local dealer or Walinga representative for the most current revision of your machine's manual or if you have any questions.

## INTENDED USE

The Walinga blower has been designed for use in dilute phase pneumatic conveying applications. Use of the machine in any other manner is considered as contrary to the intended use. Compliance with and strict adherence to the methods of operation, maintenance, and repair, as specified by Walinga in this manual, also constitute essential elements of the intended use.

The blower must be operated, maintained and serviced only by persons who are familiar with its particular characteristics and have been acquainted with the relevant safety procedures in this manual. Any individual who has not familiarized themselves with the content of this manual is considered untrained. Untrained persons are considered unqualified to operate, maintain or service a blower. It is the responsibility of the owner and/or operator to train new operators and ensure they have read and understood this manual.

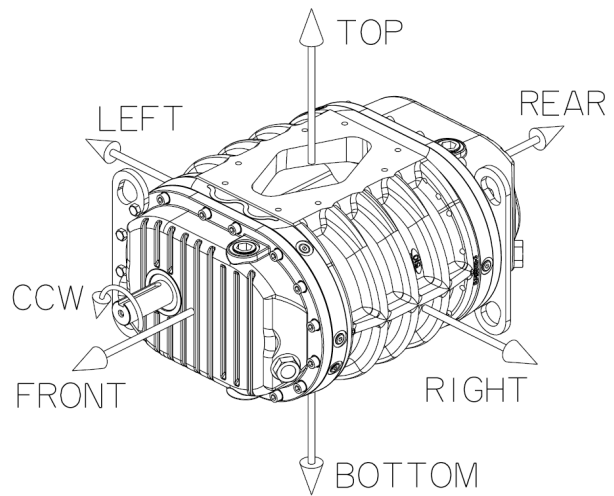
Accident prevention regulations, all other generally recognized regulations on safety and occupational health and safety, and all road traffic regulations must be observed at all times.

Any unauthorized modifications carried out to the blower may relieve Walinga of liability for any resulting damage or injury and is considered contrary to the intended use.

## DIRECTIONAL REFERENCES

To avoid confusion, the following directions will be used as a standard throughout the manual:

<b>TOP</b>	The inlet side of the blower
<b>BOTTOM</b>	The outlet side of the blower
<b>FRONT</b>	The drive end of the blower
<b>REAR</b>	The idle end of the blower
<b>LEFT</b>	The left-hand side as viewed from the FRONT of the blower
<b>RIGHT</b>	The right-hand side as viewed from the FRONT of the blower
<b>CCW</b>	The standard counter-clockwise rotational direction of the standard left-hand drive driving impeller



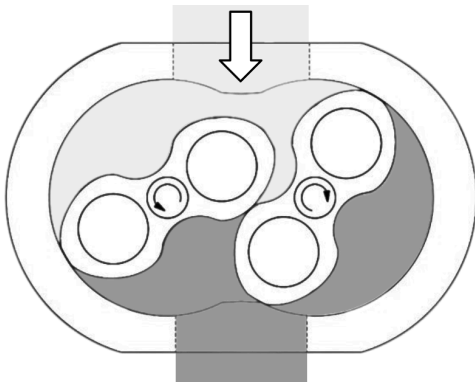
**Figure 2-1: Directional references**

## BLOWERS IN PNEUMATIC CONVEYING SYSTEMS

Pneumatic conveying systems use air to move materials and work best with free-flowing, powdered or granular materials. The efficient operation depends on many factors including air flows, line sizes, source power, operating methods, and suction and discharge line arrangements, among others. Blowers are used in a variety of Walinga systems such as in Engineered Transportation Equipment in discharge and transfer systems, as well as in Agri-Vacs, Central-Vacs, Ultra-Vacs, Ultra-Veyors, Silo-Fillers, and Barge Unloaders.

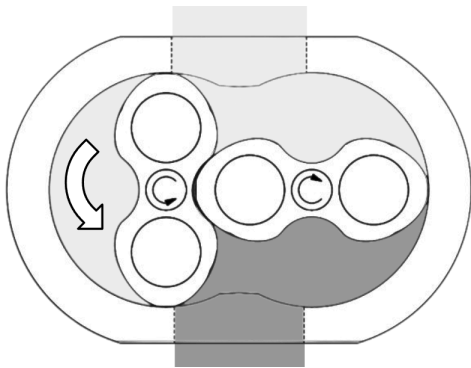
At the most basic level, Walinga's positive-displacement blower functions as an air pump, capable of producing vacuum and pressurized air flows on the inlet and outlet sides of the blower respectively through the use of a twin lobe impeller. In a Walinga blower, the external shaft is connected to the driving impeller, which is the left impeller for the standard left-hand drive configuration. The driving impeller rotates in a counter-clockwise direction, and through the timing gear assembly, causes the driven impeller to rotate in the opposite, clockwise, direction.

A simplified representation of the movement of air through a blower in a pneumatic conveying system can be seen in **Figure 2-2** through **Figure 2-4**. In these figures, the volume shown in light gray is air that is at atmospheric pressure or vacuum, dependent on the blower application, and the volume shown in dark gray is pressurized.



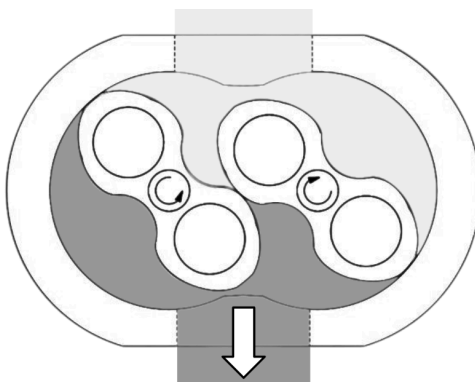
**Figure 2-2: Step 1**

As the impellers rotate, air is drawn into the inlet side of the blower.



**Figure 2-3: Step 2**

A constant volume of air becomes trapped between the impeller lobes and the casing as it continues to rotate.



**Figure 2-4: Step 3**

As the impeller continues to rotate, the trapped pocket of air is released to the outlet side of the blower.

As the pocket of air is released to the outlet of the blower, the discharge line equalizes the pressure as the air is forced out of the blower casing, resulting in a pressurized air stream in the discharge lines. The load resistance of the conveyed materials in the discharge lines provide a back pressure, further increasing the pressure and improving the function of the blower.



# Machine Configuration

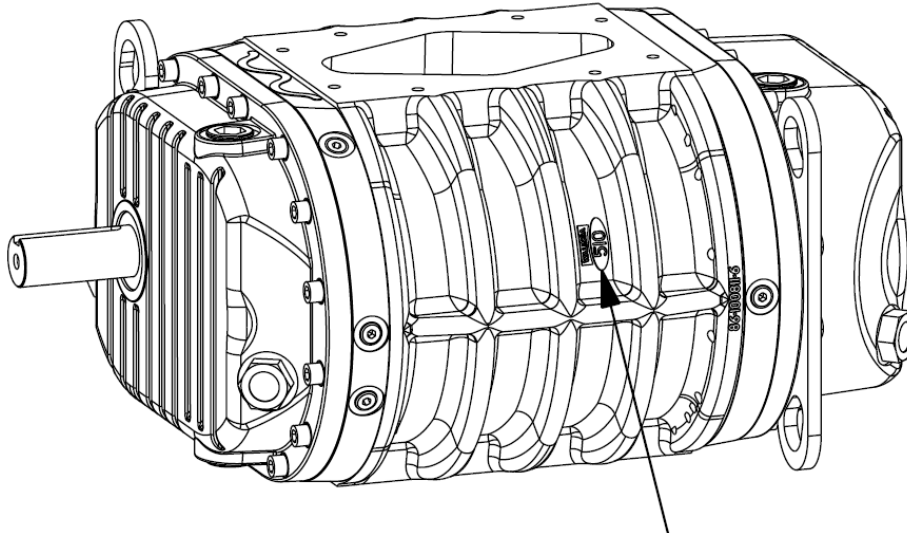
---

BLOWER MODELS

---

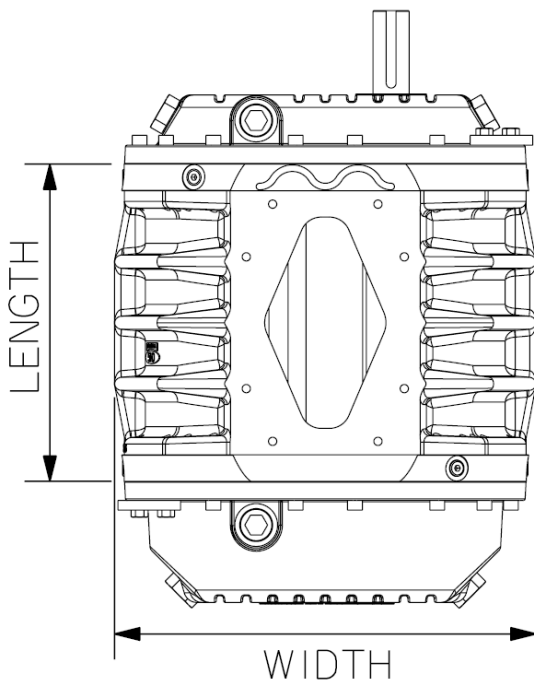
**MODEL SIZES**

Walinga blowers are available in a variety of sizes. To identify the size of your blower, refer to the embossed model label on the side of the blower casing as seen in **Figure 3-1**.



**Figure 3-1: Model identification**

If you are unable to locate or read the embossed label, refer to **Figure 3-2** and **Table 3-1** for the casing reference dimension of each specific model for identification.



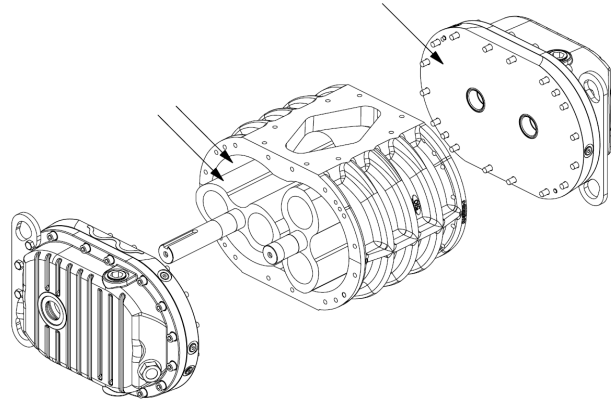
**Table 3-1: Casing reference dimension**

Model	Casing Length	Casing Width
506	6 in (152.4 mm)	15.71 in (399.0 mm)
510	10 in (254.0 mm)	16.01 in (406.7 m)
614	14 in (355.6 mm)	18.76 in (476.5 mm)
816	16 in (406.4 mm)	24.93 in (633.2 mm)
1020	20 in (508.0 mm)	31.50 in (800.1 mm)

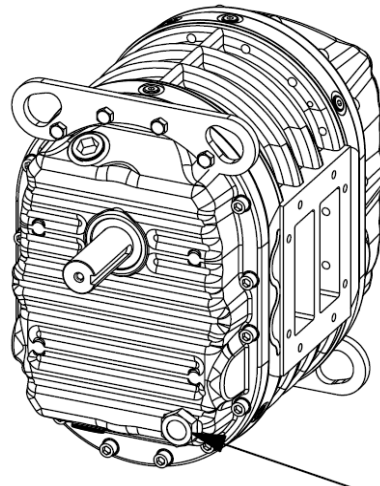
**Figure 3-2: Casing reference dimensions**

**MODEL VARIATIONS****GENERAL****HARD COATING (HC)**

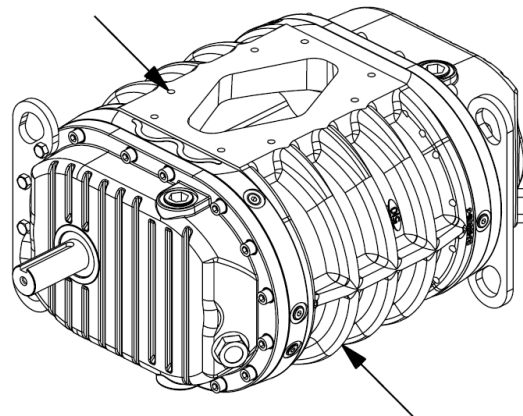
A hard coating is applied to the interior machined surfaces of the casing, headplates, and impeller assemblies, providing improved wear resistance on all Walinga blowers.

**VERTICAL MOUNT (VM)**

Specialized cover and sight glass placement to achieve correct oil levels, allow for certain blowers to be mounted in a vertical orientation.

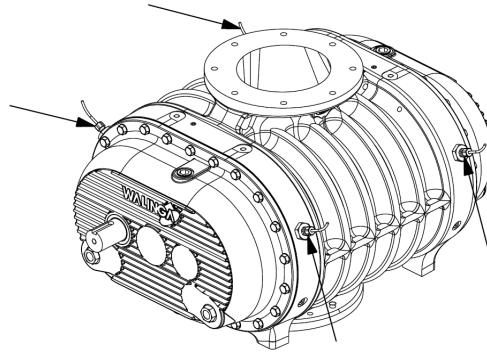
**METRIC MOUNT (MM)**

The mounting holes of the blower casing are threaded to accommodate a M12-1.75 bolt.

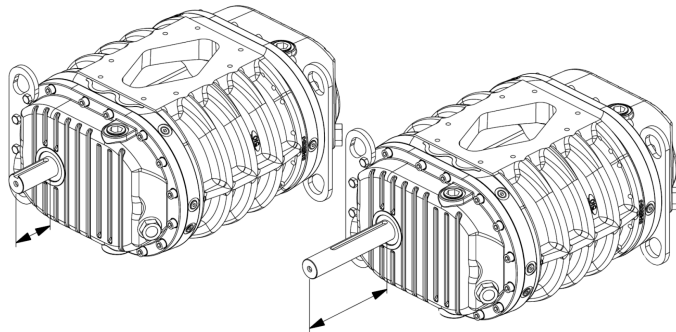


**SENSOR (S)**

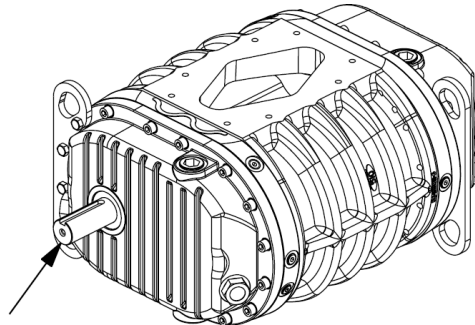
Specially designed components for specific blower models can accommodate sensors to monitor vibration and temperature.

**DRIVE****SHAFT LENGTH (SL)**

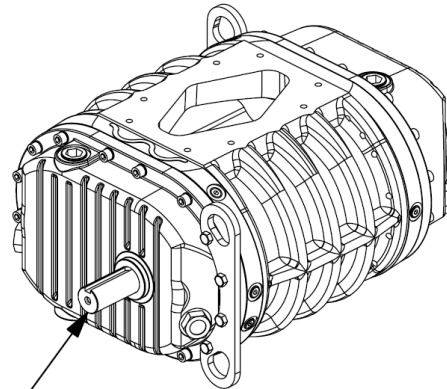
To accommodate the wide range of applications and drive configurations, some blower models are available with varying drive shaft lengths.

**LEFT-HAND DRIVE (LHD)**

The standard position of the drive shaft of Walinga blowers is on the left side of the assembly.

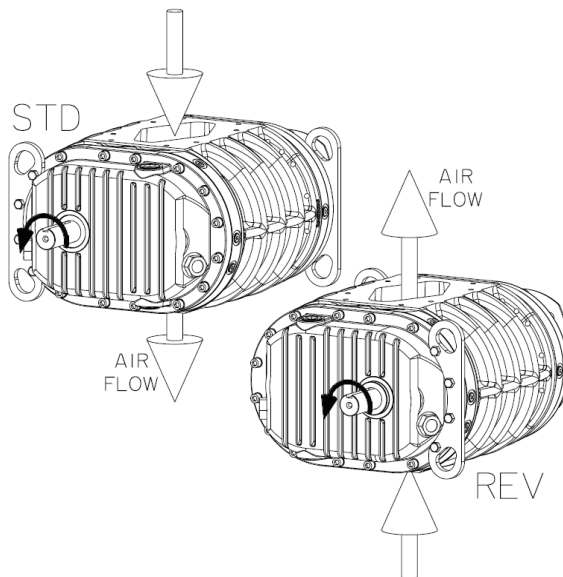
**RIGHT-HAND DRIVE (RHD)**

The drive shaft may also be mounted on the right side of the assembly, to accommodate varying drive system configurations or external restrictions.



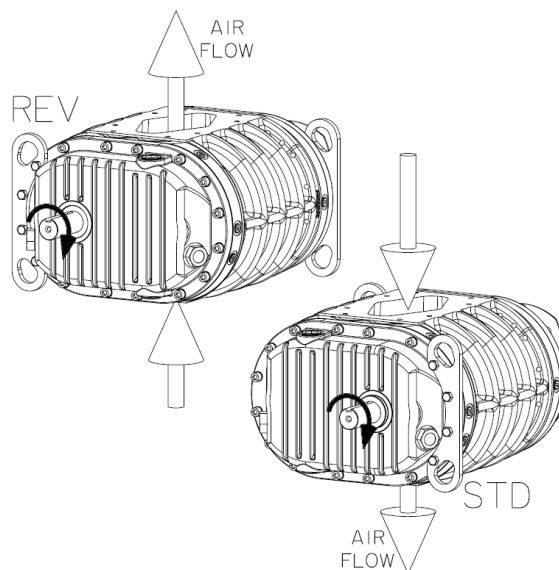
**COUNTER-CLOCKWISE (CCW)**

The standard rotation of the drive shaft and driving impeller for LHD blowers is in a counter-clockwise direction to draw air into the top of the assembly and discharge the air out of the bottom of the blower. Some special applications may require a RHD blower to operate in the reverse direction. The drive shaft will rotate counter-clockwise and the air will be drawn into the bottom of the blower and discharged out of the top of the blower.



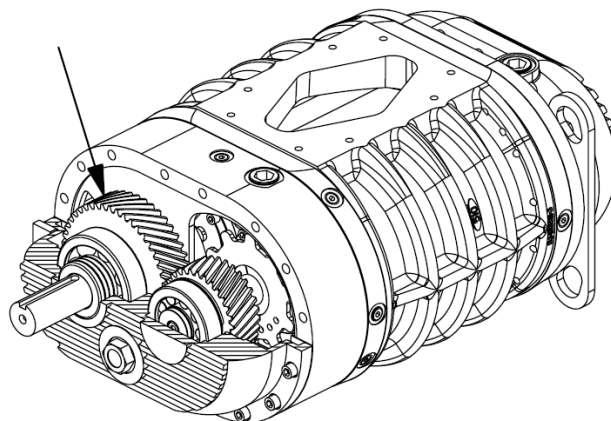
**CLOCKWISE (CW)**

The standard rotation of the drive shaft and driving impeller for RHD blowers is in a clockwise direction to draw air into the top of the assembly and discharge the air out of the bottom of the blower. Some special applications may require a LHD blower to operate in the reverse direction. The drive shaft will rotate clockwise and the air will be drawn into the bottom of the blower and discharged out of the top of the blower.



**GEARHEAD (GH)**

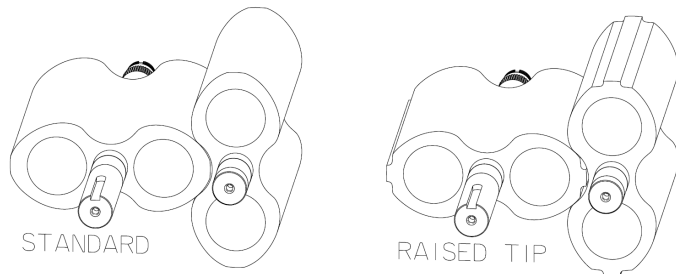
A gear set with a specific ratio may be mounted to the drive shaft to achieve the correct operational rotational speed in order to accommodate restrictions of drive systems.



## IMPELLER

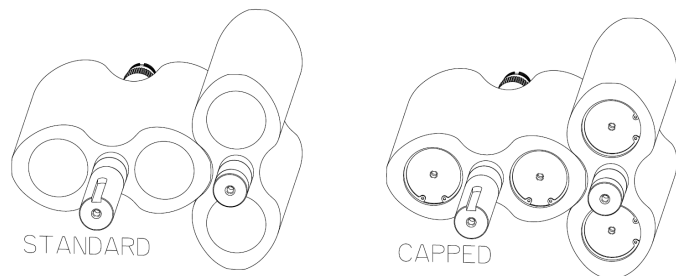
### RAISED TIPS (RT)

The impeller lobes have a specialized tip profile to prevent residue build-up on the internal blower surfaces when conveying certain commodities with high oil content, such as oilseed crops.



### CAPPED IMPELLERS (CAP)

The impeller lobes are equipped with a plug in both ends of the impeller. This assists in the prevention of product or debris accumulation inside the impeller.



### TIGHT CLEARANCES (T)

The blower has been assembled with tighter impeller clearances than standard to increase capacity. Blowers with tight clearances are suitable for use in vacuum-**only** or pressure-**only** applications.

### CENTERED CLEARANCES (CTR)

The impellers have been assembled and positioned with specific tip clearances at the top and bottom of the casing and neutral timing clearances to allow for bi-directional usage. Centered clearances and neutral timing will result in lower performance than the standard tip clearances and advanced timing.



# Safety

---

## BLOWER MODELS

---

## SAFETY ALERT SYMBOL



This safety alert symbol means: **ATTENTION! BECOME ALERT! YOUR SAFETY IS INVOLVED!**

The safety alert symbol identifies important safety messages on the blower and in the operator's manual. When you see this symbol, be alert to the possibility of personal injury or death. Follow the instructions in the safety message.

Safety is one of the top priorities and should always be taken into consideration because:

- Accidents disable and kill
- Accidents cost
- Accidents can be avoided

## SIGNAL WORDS

Take note of the signal words **DANGER**, **WARNING**, and **CAUTION** when used with a safety message, as well as the use of the words **IMPORTANT** and **NOTE**. The appropriate signal word for each message has been selected using the following guidelines:

<b>DANGER</b>	Indicates an imminently hazardous situation that, if not avoided, will result in death or serious injury. This signal word is limited to the most extreme situations, typically for machine components that, for functional purposes, cannot be guarded. The associated color is red.
<b>WARNING</b>	Indicates a potentially hazardous situation that, if not avoided, could result in death or serious injury, and includes hazards that are exposed when guards are removed. It may also be used to alert against unsafe practices. The associated color is orange.
<b>CAUTION</b>	Indicates a potentially hazardous situation that, if not avoided, may result in minor or moderate injury. It may also be used to alert against unsafe practices. The associated color is yellow.
<b>IMPORTANT</b>	Indicates a potentially hazardous situation that, if not avoided, may result in damage to the machine. It may also be used to alert against unsafe practices. The associated color is blue or white.
<b>NOTE</b>	Indicates supplementary information that the operator must be aware of for the safe or proper use of the machine. The associated color is blue or white.

## GENERAL SAFETY

**You** are responsible for the **safe** operation and maintenance of your blower. **You** must ensure that you and anyone else who will operate, maintain, or work around your pneumatic conveying equipment is familiar with the operating and maintenance procedures and safety information contained in this manual. This manual will provide information for safety practices that must be adhered to while operating a blower. Remember, **you** are the key to safety. Good safety practices not only protect you, but also the people around you. Make good safety practices a working part of your safety program. Be certain that **everyone** operating the pneumatic conveying equipment is familiar with the recommended procedures and follows all safety precautions. Remember, most accidents can be prevented; do not risk injury or death.

Owners must provide operating instructions to operators or employees before initially allowing them to operate the equipment, and must review this information at least annually thereafter. The most important safety feature of Walinga equipment is a **safe** operator. It is the operator's responsibility to read and understand all aspects of this manual and to follow all safety and operational instructions. An individual who has not read, understood, and been trained to follow all operation and safety procedures is considered an untrained operator and is unqualified and unauthorized to operate a blower. Untrained operators expose themselves and bystanders to potential serious injury or death.

Before servicing, adjusting, or repairing a blower, place all controls in neutral, stop and lock-out the power source, and wait for all moving parts to stop.

In case of emergency, keep a first-aid kit and fire extinguisher readily available and stored in a highly visible place. Be familiar with the use of each of these tools. Also keep the phone number for the emergency medical center for your area readily available.

Use appropriate personal protective equipment including, but not limited to: a hard hat, protective shoes with slip-resistant soles, protective glasses or goggles, heavy gloves, wet weather gear, and hearing protection. Long hair and loose clothing must be secured to avoid potential injury as a result of coming into contact with moving or rotating components of the blower. Hands and feet must also be kept clear of any moving or rotating components.

Ensure all electrical equipment is properly grounded. All electrical connections made to the system must be in compliance and accordance with local electrical codes and/or the National Electric Code (NFPA 70) as required.

In order to provide a better view or visualization, certain diagrams in this manual may show an assembly or machine feature with a safety shield or guard removed. This is for illustrative purposes only. Equipment must never be operated in this condition. Keep all guards and shields in place. If it is necessary to remove a shield or guard for maintenance or adjustment, the shield or guard must be replaced prior to use.

Replace any safety sign or instructional sign that has been damaged or become illegible. The most common locations and a reproduction of the safety signs located on pneumatic conveying systems using a blower are outlined later in this section. In addition to the design and configuration of this implement, including safety signs and safety equipment, hazard control and accident prevention are dependent upon the awareness, concern, prudence, and proper training of personnel involved in the operation, transport, maintenance, and storage of the machine. Refer to the safety messages and operational instructions in each of the appropriate sections of the auxiliary equipment and machine manuals. Pay careful attention to the safety signs affixed to the auxiliary equipment and the machine.

Never use alcoholic beverages, narcotics, or other intoxicants which could hinder alertness or coordination while operating a blower. Consult your doctor about operating this machine while taking prescription medications.

Under no circumstances should young children be allowed to work with this equipment. Do not allow children or any other individuals to climb on or play around the blower at any time. This equipment is dangerous to children and individuals unfamiliar with its operation. The operator must be a responsible, properly trained, and physically able person trained in the blower's operation. If there are elderly individuals assisting with the operation, their physical limitations must be recognized and accommodated. Do not allow any individuals to operate or assemble this machine until they have read and understood the safety precautions and operational procedures in this manual.

Never exceed the limits of a piece of machinery. If its ability to perform a task, or to do so safely, is in question, do **not** attempt it. Do not modify the equipment in any way. Unauthorized modification may result in serious injury or death and may impair the function, safety or life of the equipment, as well as void the warranty.

## INSTALLATION SAFETY

- Disconnect and remove all mechanical locks, anchor chains and any other transport devices that would hinder or prohibit the normal function of the blower upon start-up. Serious damage to the machine and/or personal injury to the operator or bystanders may result from attempting to operate the machine while mechanical locking devices are still attached and secured.
- Ensure there is a minimum of one additional individual available for assistance with elevating, moving, or connecting other equipment.
- Ensure the blower system is equipped with all necessary relief valves. Any system in which the intake operates under vacuum pressure must be equipped with a vacuum relief valve. This valve must open to allow air to flow into the blower inlet to prevent overheating in the event of an inlet blockage or obstruction. Any system in which the outlet operates under positive pressure must be equipped with a pressure relief valve. This valve must open to allow air to flow out of the blower outlet assembly to prevent overpressurization in the event of an outlet blockage or obstruction.

## STORAGE SAFETY

- Store the equipment in an area away from human activity.
- The storage area should be dry with a firm, level surface.
- Do not permit children to play on or around the stored machine.
- Ensure all mechanical locks are safely and positively connected.

## PRE-OPERATION SAFETY

- Safety is a primary concern in the design and manufacturing of Walinga products. However, these efforts can be negated by a single careless act of an operator or bystander.
- It is the responsibility of the operator to read and understand all safety and operational instructions contained within the operator's manual and the manuals of any auxiliary equipment. Working with unfamiliar equipment can lead to careless injuries. Ensure you and any individual who will be working with or around the blower understands the information provided in the operator's manuals and is instructed in the safe and proper use of the machine.
- Refer to the auxiliary equipment's operator's manual to become familiar with the controls of the blower and know how to stop the blower and any other auxiliary equipment quickly in the event of an emergency.

- Properly train all new personnel and review instructions frequently with existing workers. Ensure only a properly trained and physically able individual will operate the machine. Any individual who has not read and understood all operating and safety procedures is not qualified to operate the machine.
- Ensure all necessary personal protective equipment including a hard hat, safety glasses or goggles, safety shoes, gloves, wet weather gear, and hearing protection are in good condition. Do not allow loose long hair, loose fitting clothing, or jewelry to be around the equipment. Prolonged exposure to loud noise may cause permanent hearing loss. Motors or attached equipment can often produce enough noise to cause permanent, partial hearing loss. It is recommended that hearing protection is always used if the noise levels at the operator's position exceeds 80 dB. Noise over 85 dB on a long-term basis can cause severe hearing loss. Noise over 90 dB in close proximity to the operator over a long-term basis may cause permanent, total hearing loss. Hearing loss from loud noise is cumulative over a lifetime without the hope of natural recovery.
- Clear the working area of debris, trash or hidden obstacles that may be hooked or snagged, causing injury, damage or tripping hazards.
- Operate only in daylight or with sufficient artificial lighting.
- Ensure the machine is properly anchored, adjusted and in good operating condition. Check the machine over for any loose bolts, worn parts, cracks, leaks, etc., and make any necessary repairs. Always follow the maintenance instructions.
- Ensure that all safety shielding and guarding and safety signs are properly installed and secured, and are in good condition.
- The rotating impellers of the blower can cause serious bodily injury. The inlet and outlet of the blower must always be properly guarded to prevent contact with the impellers.

## **OPERATIONAL SAFETY**

- Read and understand the operator's manual and all safety signs before use.
- Do not operate when any guards are damaged or removed. Install and secure all guards before operation.
- Do not open any access point to the blower while in operation.
- Keep hands, feet, clothing, hair, and jewelry away from all moving and/or rotating parts.
- Do not allow any individuals to climb on the blower at any time.
- Clear the area of all bystanders, especially small children, before operation.
- Keep all safety signs clean and unobstructed.
- Wear appropriate personal protective equipment while operating.

- For systems functioning under vacuum pressure, do not place any intake nozzle near your feet when standing on top of the conveyed material; the suction produced by the blower is sufficient to pull the nozzle and operator into the pile. If the pile is deep enough, the operator can become submerged in the material and suffocate.
- In the event of a blockage in the blower, shut down the system before removing the obstruction. Never reach into the blower with hands or tools while in operation to clear an obstruction. All power sources must be disconnected and/or locked out before any guards or access points are removed or opened to manually dislodge an obstruction.

## MAINTENANCE SAFETY

- Read, understand and follow all operating, maintenance and safety information in the operator's manual.
- Clear the area of bystanders, especially small children, when carrying out any maintenance or repairs or making any adjustments.
- Follow good shop practices:
  - Keep the service area clean and dry.
  - Ensure electrical outlets and tools are properly grounded.
  - Use adequate lightning for the job at hand.
- Ensure a fire extinguisher and first aid kit are available, and know how to use them.
- Place all controls in neutral, stop and lock-out the power source, and wait for all moving parts to stop before servicing, adjusting or maintaining.
- Use required personal protective equipment previously outlined.
- Use only tools, jacks and hoists of sufficient capacity for the job.
- Keep hands, feet, hair, clothing, and jewelry away from all moving and/or rotating parts.
- Ensure all guards are in place and secured when maintenance work is complete.

## MACHINE SAFETY SIGNS

The safety signs affixed to the blower and auxiliary equipment provide important information regarding your safety and the safe operation of the machine. Familiarize yourself with all safety signs before operation.

- Safety signs must be clean and legible at all times.
- Replace any safety signs that are missing, damaged, or have become illegible.
- Any replaced parts that previously displayed a safety sign, must display the current safety sign.
- Safety signs are available at no cost from your representative, dealer, or directly from Walinga.

If a safety sign has become damaged, illegible or a new safety sign must be installed on a replacement component, proceed as follows:

1. Ensure the installation area is clean and dry.
2. Ensure the temperature of the equipment is above 50 °F (10 °C).
3. Locate the correct position of the safety sign before removing the backing paper.
4. Remove the smallest portion of the split backing paper.
5. Align the safety sign over the correct position and carefully press the small portion with the exposed adhesive backing in place.
6. Slowly peel back the remaining paper and carefully smooth the remaining portions of the safety sign in place.
7. Small air pockets can be pierced with a pin and smoothed out using the backing paper.

Safety signs affixed to the equipment are standardized as follows:

- Danger safety signs are red in color
- Warning safety signs are orange in color
- Caution safety signs are yellow in color
- Informational safety signs are white or blue in color
- Each safety sign is printed with its respective Walinga part number located in the bottom right corner. Reference this number on the safety sign, or identified in the following reproductions, to obtain replacement safety signs.

Due to the wide variety of systems that utilize a blower, refer to the operator's manual of the auxiliary equipment for the exact location, quantity and part number of each safety sign. The following safety signs are commonly used in close proximity and in relation to a blower:

**Figure 4-1**

**Part Number:** 53-15635-6

**Approximate Location:**

Located near the drive shaft, as equipped



**Figure 4-2**

**Part Number:** 53-17704-6

**Approximate Location:**

Located near the drive shaft guard, as equipped



**Figure 4-3**

**Part Number:** 53-129804-6

**Approximate Location:**

Located near the muffler, as equipped



**Figure 4-4**

**Part Number:** 53-135151-6

**Approximate Location:**

Located near intake and discharge conveying lines

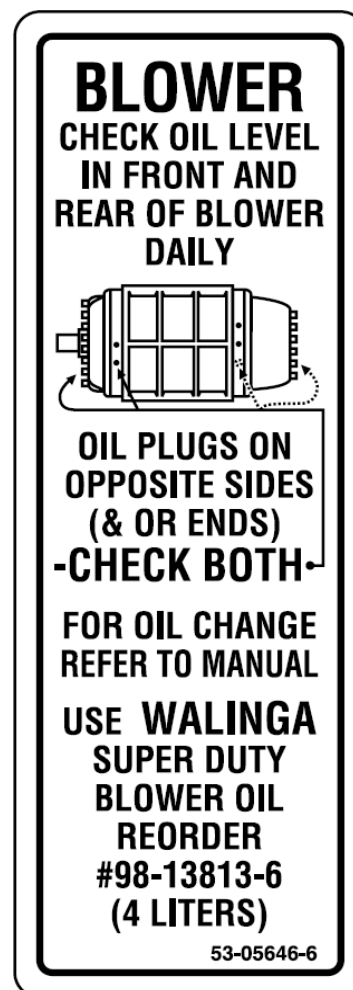


**Figure 4-5**

**Part Number:** 53-05646-6

**Approximate Location:**

Located on the top side of the idle end cover



**Figure 4-6**

**Part Number:** 53-05647-6

**Approximate Location:**

Located on the side of both drive and idle end covers, centered with the oil level plugs



**Figure 4-7**

**Part Number:** 53-137791-6

**Approximate Location:**

Located near any access door on the vacuum side of the system

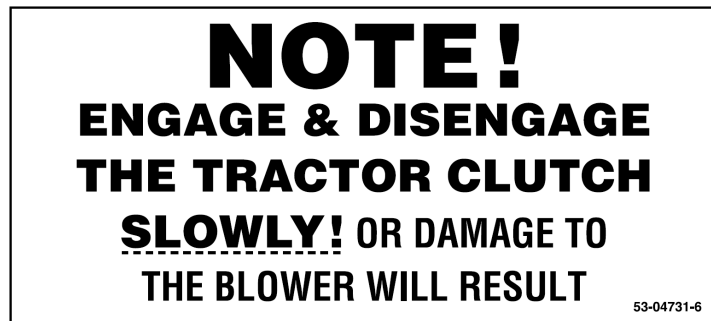


**Figure 4-8**

**Part Number:** 53-04731-6

**Approximate Location:**

Located near the drive system of PCS equipment



**Figure 4-9**

**Part Number:** 53-18674-6

**Approximate Location:**

Located near the blower shaft support bearing plate, as equipped



**Figure 4-10**

**Part Number:** 53-05649-6

**Approximate Location:**

Located below the vacuum gauge for systems working under vacuum pressure



**Figure 4-11**

**Part Number:** 53-05650-6

**Approximate Location:**

Located below the pressure gauge for systems working under positive pressure

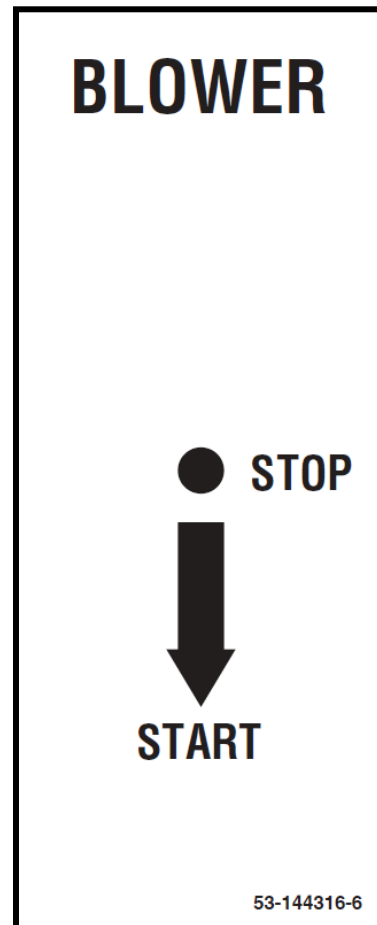


**Figure 4-12**

**Part Number:** 53-144316-6

**Approximate Location:**

Located below the blower control lever, as equipped









# Machine Life-Cycle Procedures

---

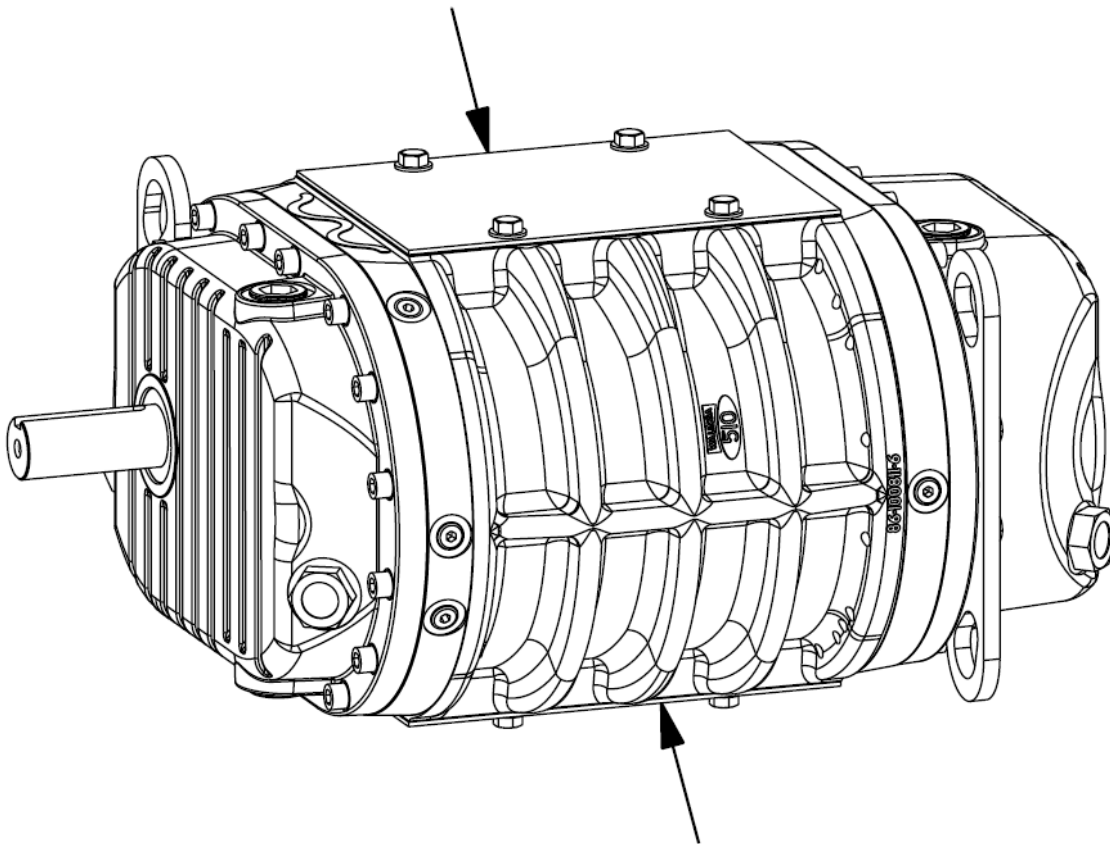
BLOWER MODELS

---

## RECEPTION, ASSEMBLY AND INITIAL SET-UP

### Reception

Blowers that are shipped separately, or as part of a partially assembled system, require extra precautions to be taken to protect the internals of the blower. To prevent premature failure due to dirt, dust, or debris that may enter during shipping, exposed blowers will be fitted with mounting gaskets and shipping debris covers on the inlet and outlet. The covers, as seen in **Figure 5-1**, must be removed from the blower during assembly and before any operation of the blower is started. Do not dispose of the debris covers as they may be used during transport or storage of the blower as required.

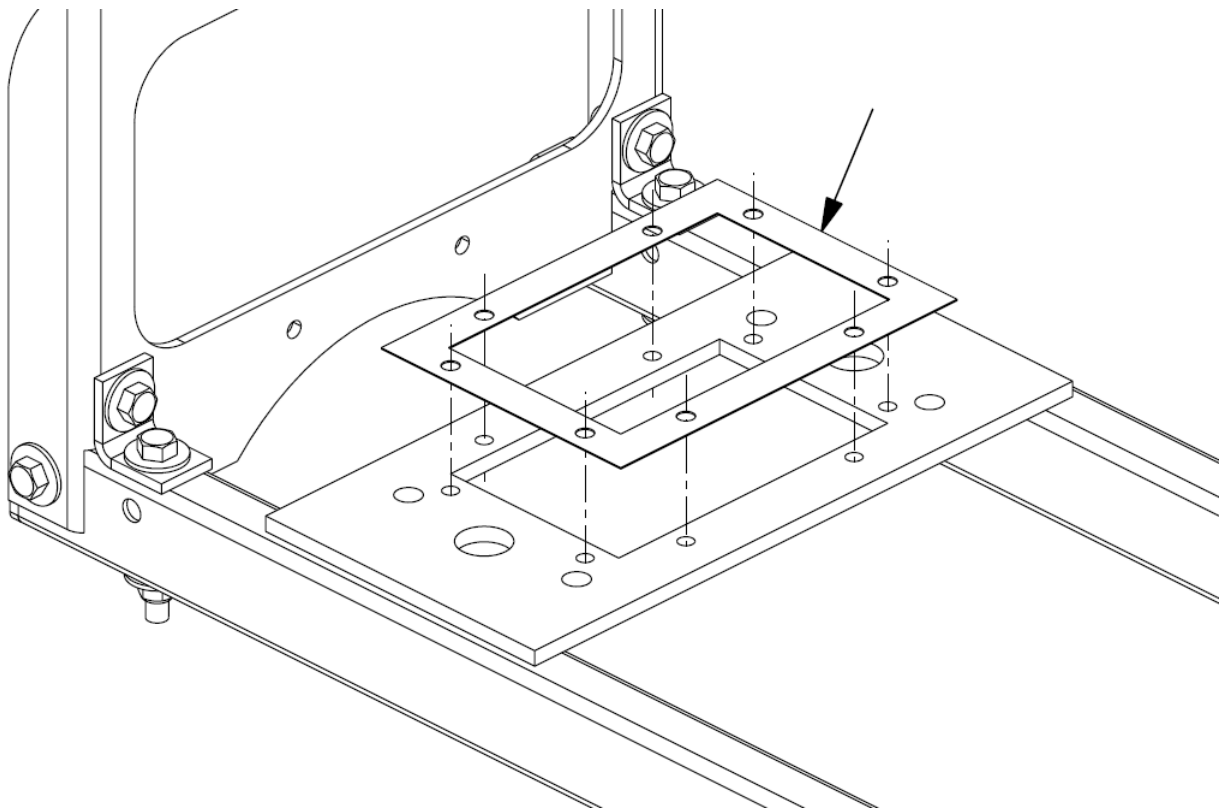


**Figure 5-1: Blower debris covers**

## Installation

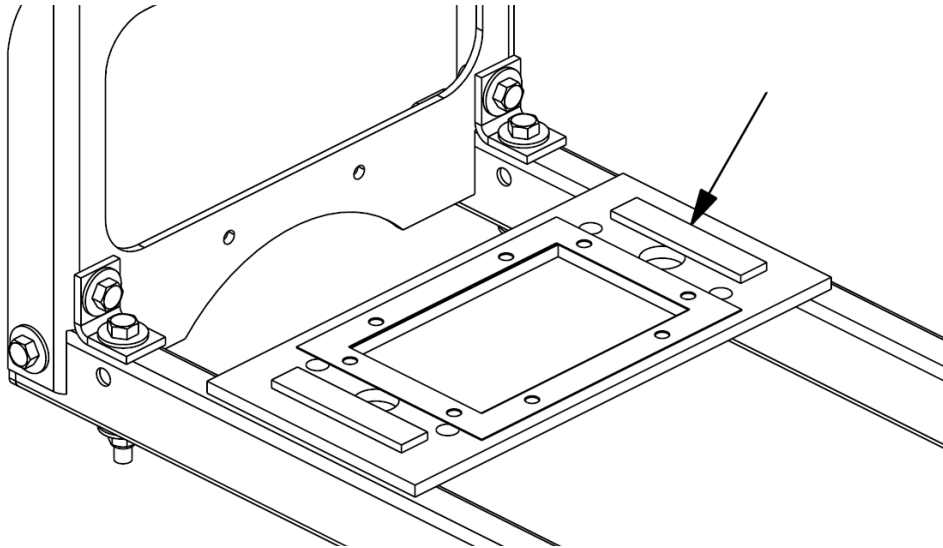
To install a blower into an existing system, refer to the auxiliary equipment's operator's manual for any specific or specialized instructions or requirements. Proper installation is crucial to the efficient and safe operation of a blower. Failure or damage to the input shaft or other blower components due to improper installation will void the warranty. As a basis, a blower may be installed as follows:

1. Clear the area of all bystanders, especially small children.
2. Ensure all controls are in neutral, and the power source is stopped and locked-out.
3. If still attached, remove any debris covers on the inlet and outlet of the blower.
4. Inspect the interior of the blower and ensure it is clear of any debris.
5. Rotate the drive shaft by hand to ensure the impellers rotate smoothly and are not obstructed.
6. Clean the system's mounting plate and ensure the surface is flat and clear of any obstructions.
7. Position a new gasket on the mounting plate, aligning the mounting holes.



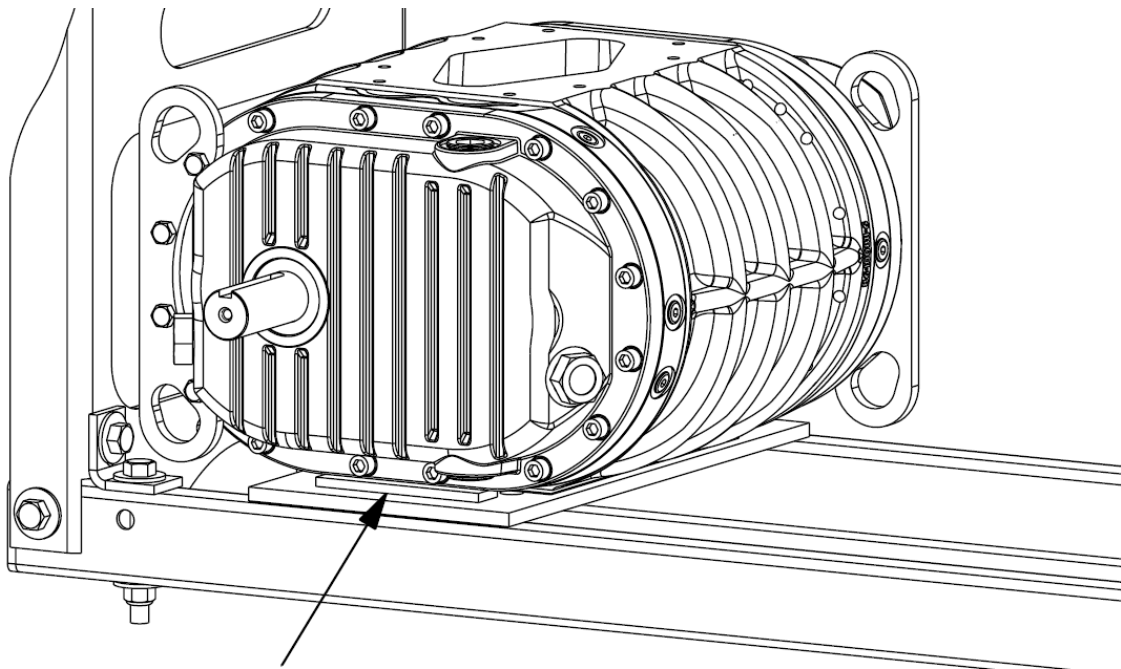
**Figure 5-2: Mounting gasket alignment**

- Place 1/4" (6.4 mm) spacers on the mounting plate to allow for repositioning of the blower without also altering the alignment of the gasket.



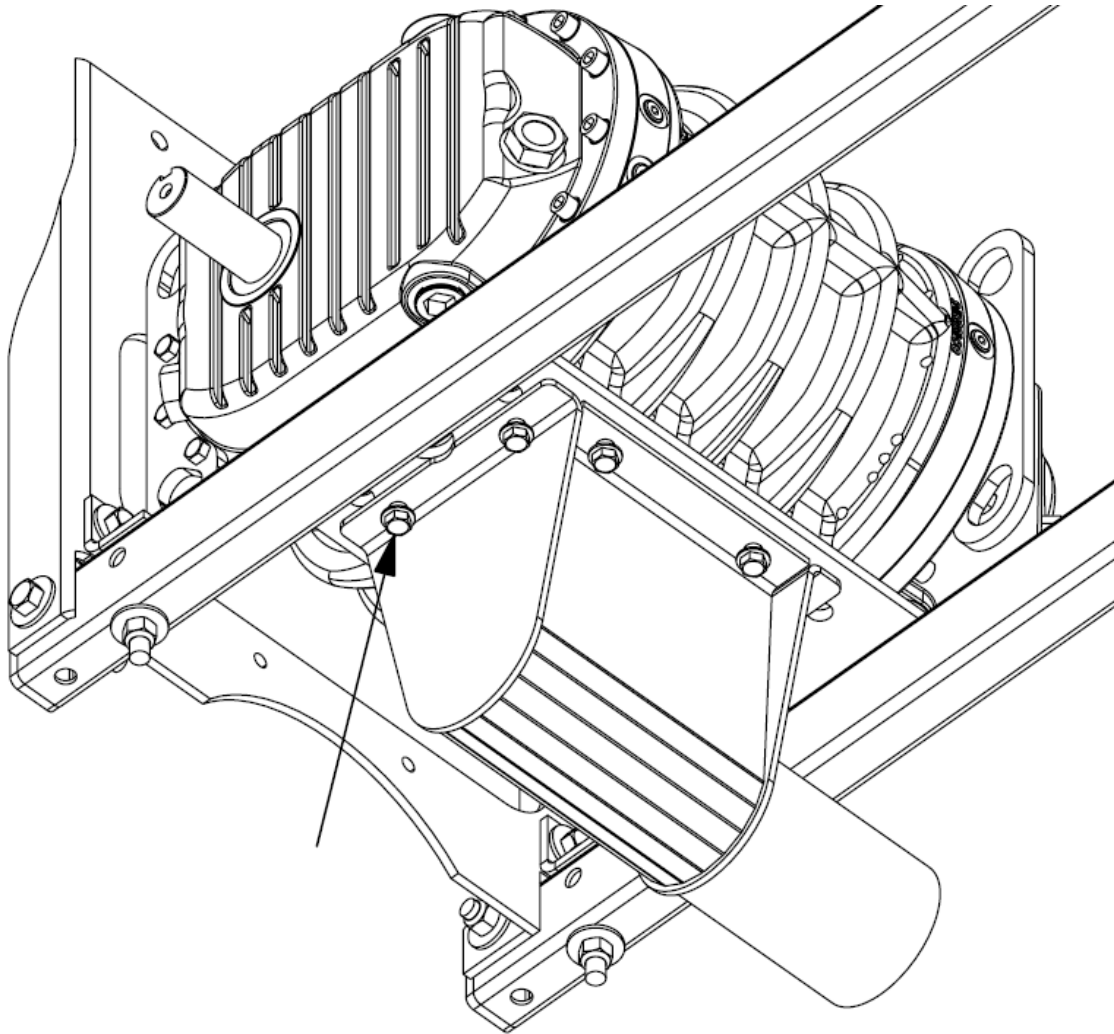
**Figure 5-3: Placement of spacers**

- Set the blower onto the spacers on the mounting plate, aligning the mounting holes of the blower, gasket and mounting plate.



**Figure 5-4: Placement of blower on spacers**

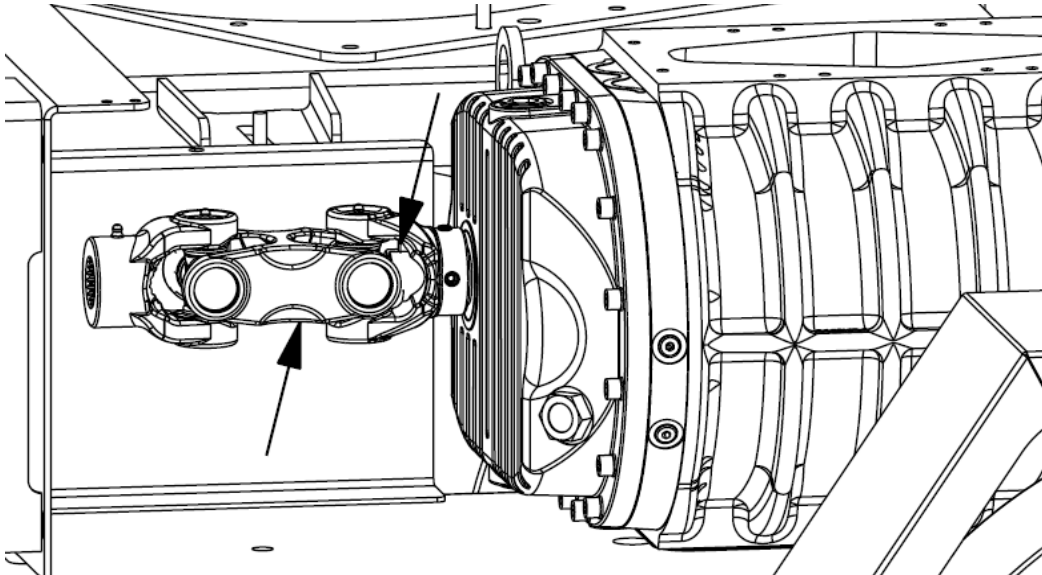
10. Refer to the auxiliary equipment's operator's manual to position all required components of the outlet assembly including any additional gaskets. Ensure the outlet assembly is equipped with a pressure relief valve as required.
11. Install the required mounting hardware and partially insert the mounting bolts into the blower casing, do not tighten.



**Figure 5-5: Partially installed mounting hardware**

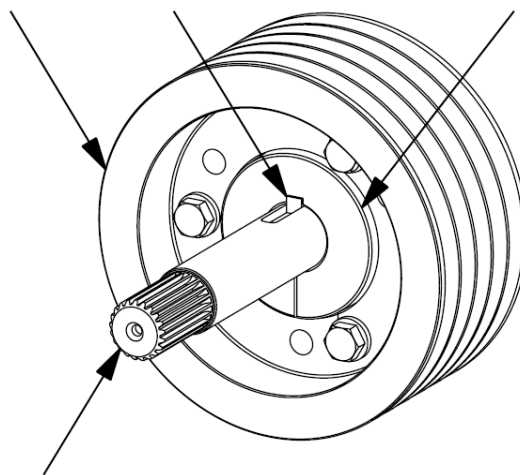
12. Ensure all mounting holes and mounting hardware are properly aligned and remove the spacers.
13. Tighten the mounting hardware to the required torque as detailed in **Section 8: Specifications**.

14. For belt driven systems, proceed as follows, otherwise proceed to **Step 15**.
  - a. Ensure the mounting fasteners of the blower are tightened to the required torque.
  - b. For systems requiring an intermediate shaft, proceed as follows:
    - i. Install the key into the blower input shaft keyway and install the double center drive shaft.



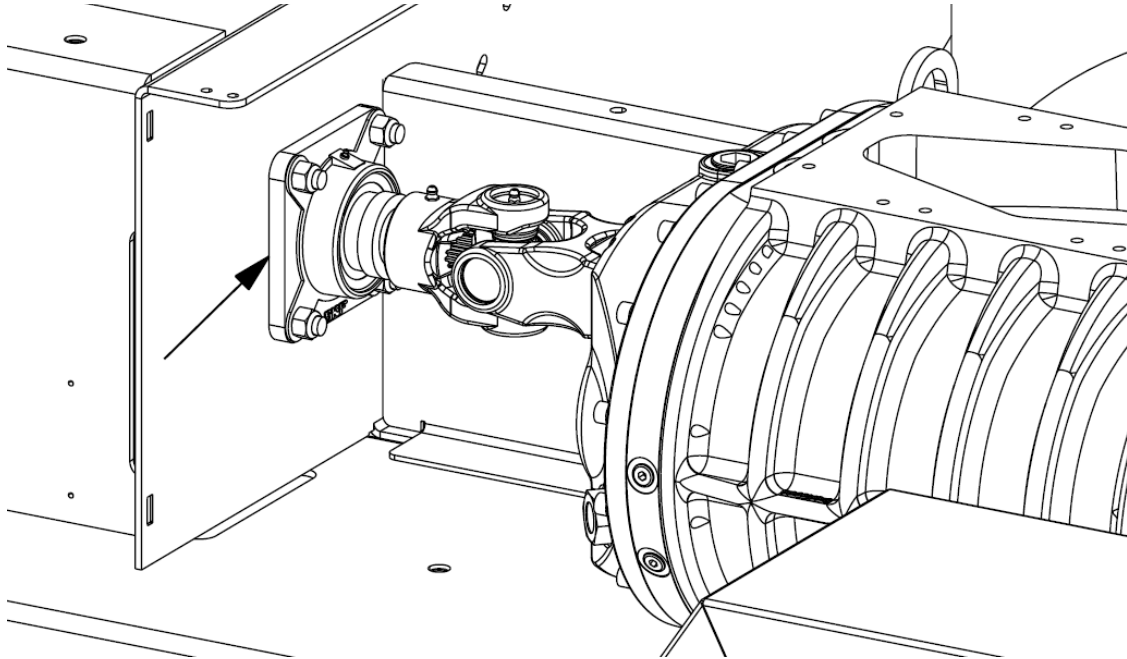
**Figure 5-6: Double center drive shaft and key installation**

- ii. Prepare the intermediate shaft by installing the key, bushing and sheave. It is good practice to mark the location of the bushing on the intermediate shaft to ensure proper sheave alignment. Tighten fasteners to the required torque.



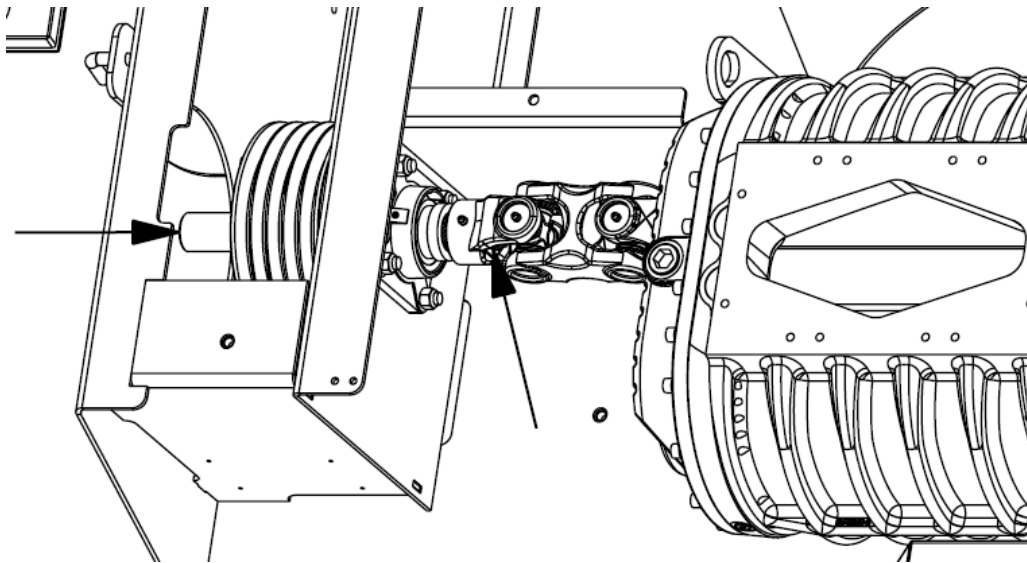
**Figure 5-7: Intermediate shaft assembly**

- iii. Install the locking collar and bearing closest to the blower onto the outer surface of the drive guard. Ensure the bearing is aligned with the blower input shaft and tighten the mounting fasteners to the required torque, do not tighten the locking collar.



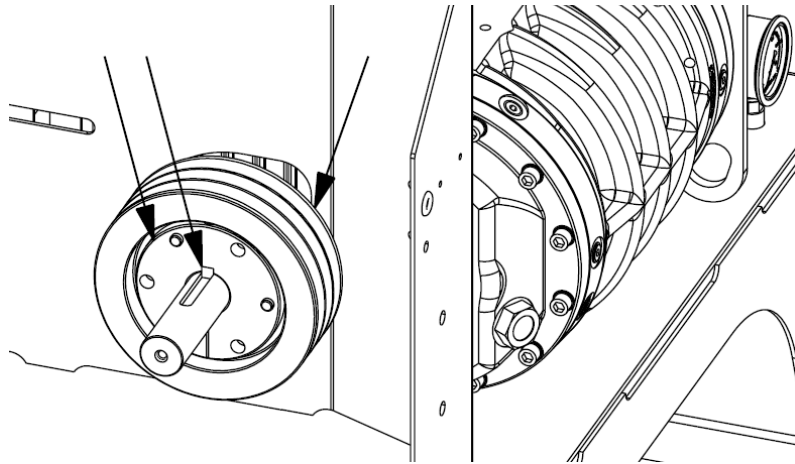
**Figure 5-8: Bearing installation**

- iv. Insert the intermediate shaft through the bearing and locking collar and into the double center drive shaft.



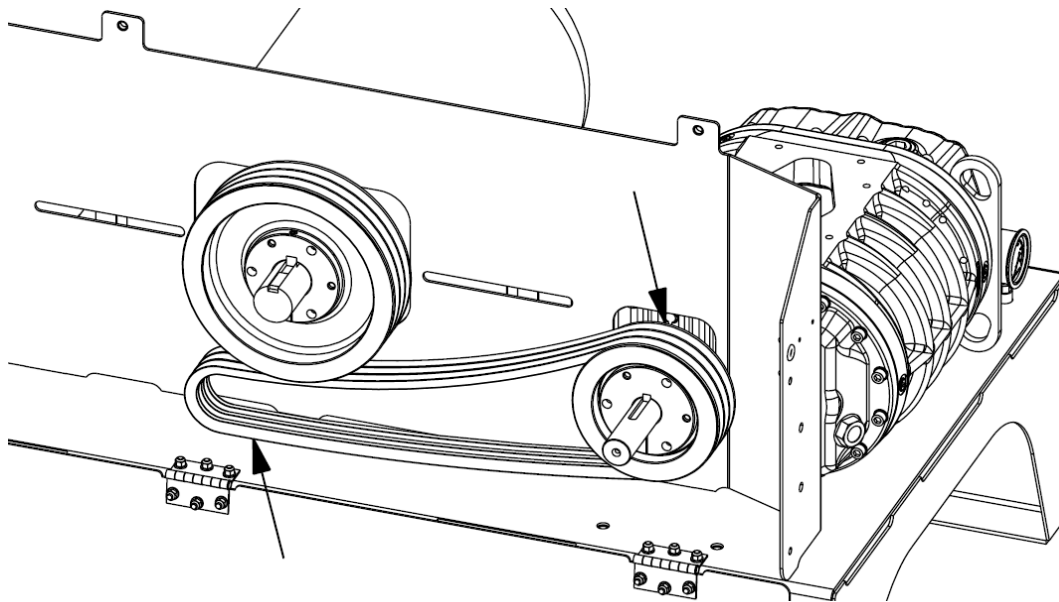
**Figure 5-9: Intermediate shaft installation**

- v. Ensure all retaining rings are installed and all fasteners and set screws are tightened to the required torque. Do not tighten the locking collar.
  - vi. Check to ensure the intermediate shaft and blower input shaft are parallel and aligned.
- c. For systems without an intermediate shaft, install the key, bushing and sheave onto the blower input shaft. Secure with all required fasteners.



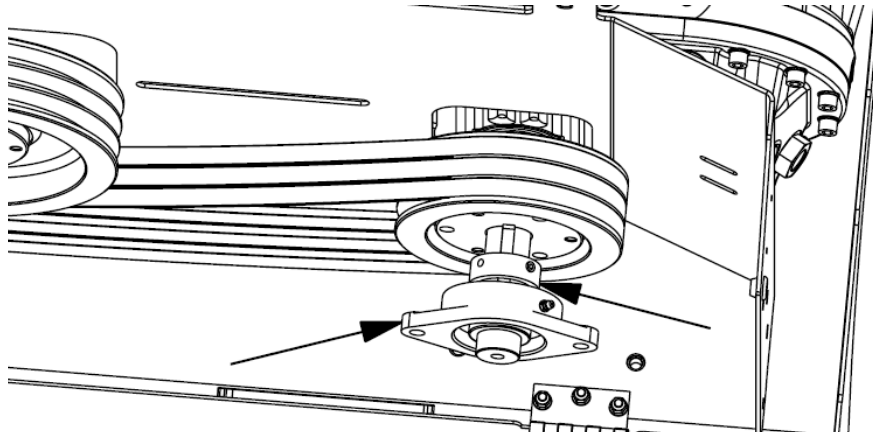
**Figure 5-10: Sheave assembly direct installation**

- d. Lay the V-belts loosely in the driven sheave only.
- NOTE:** Do **NOT** install the V-belts onto the drive sheave; side loading while mounting the outboard bearing will result in shaft failure.



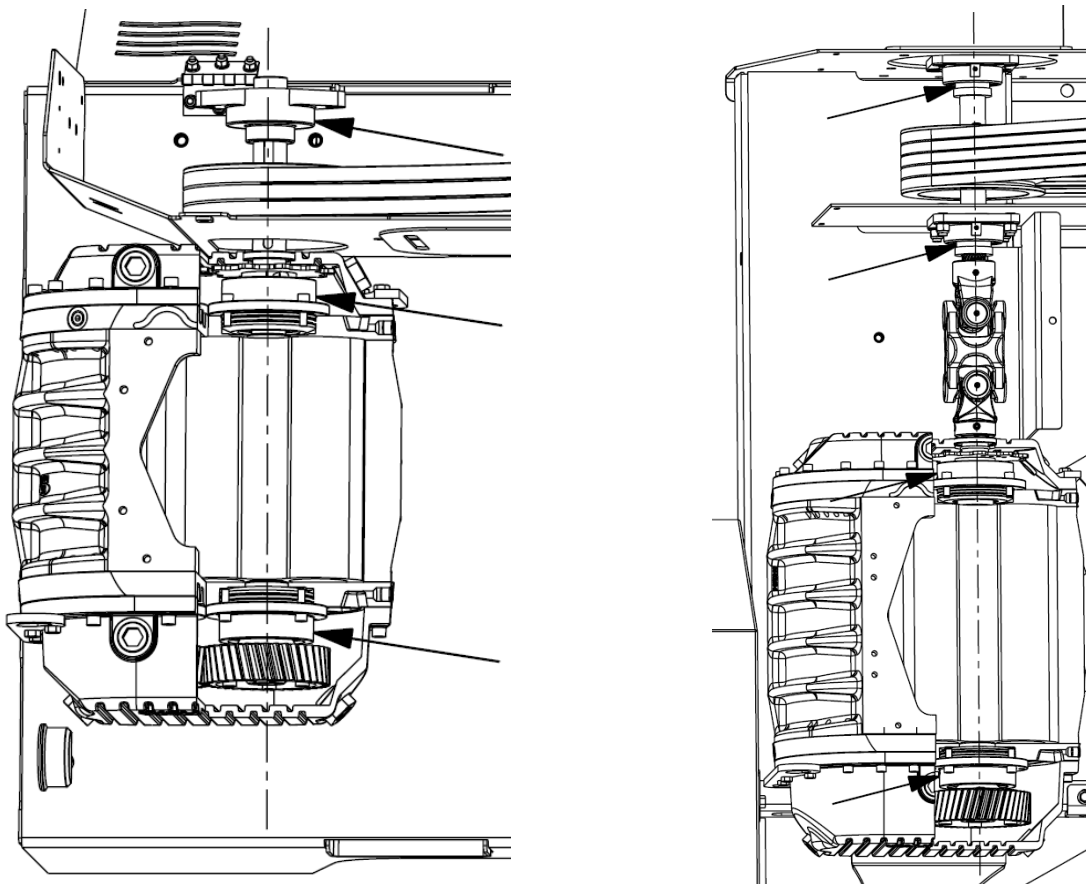
**Figure 5-11: Drive assembly installation**

- e. Install the locking collar and bearing on the blower or intermediate shaft. Do not tighten the locking collar.



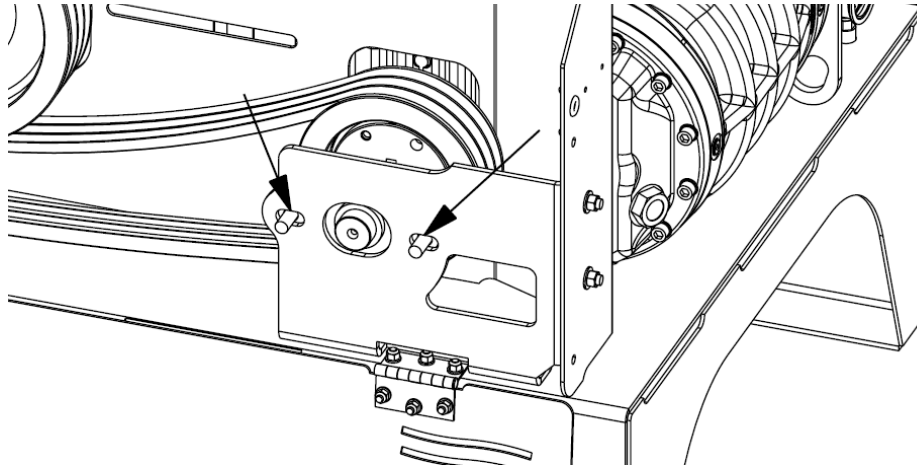
**Figure 5-12: Shaft bearing installation**

- f. Ensure all bearings and shafts are aligned and parallel with the use of a dial indicator or laser alignment system.



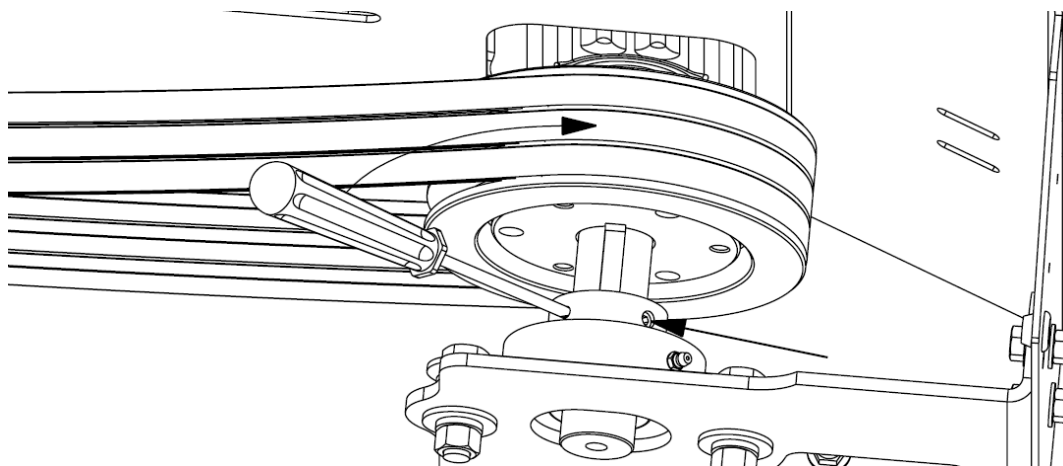
**Figure 5-13: Bearing and shaft alignment**

- g. Place the bearing support plate against the machine frame and check the alignment of the mounting holes. It is important the mounting bolts fit freely. If the bolts do not fit freely, clean out the holes with a drill or file.



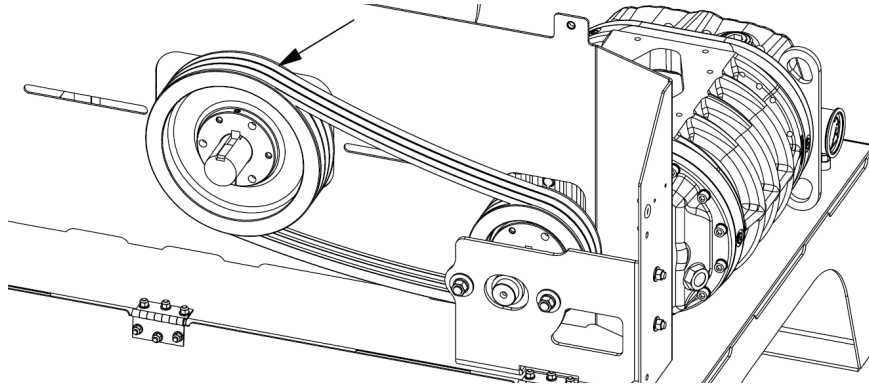
**Figure 5-14: Bearing mounting bolts**

- h. Tighten the bearing plate mounting fasteners to the required torque.
- i. If originally supplied, place the support lugs tight against the bearing plate and weld them in place to the machine frame.
- j. Lightly tap the bearing plate to center the bearing(s) on the shaft and eliminate any thrust on the blower bearing(s); the bearing(s) must move freely on the blower shaft when tapping the bearing plate.
- k. Secure the locking collar of the bearing(s) by inserting a flat chisel into the blind hole of the locking collar. Rotate the locking collar in the opposite direction of the blower shaft rotation until the locking collar is fully engaged on the inner ring of the bearing. Tighten the set screw to the required torque.



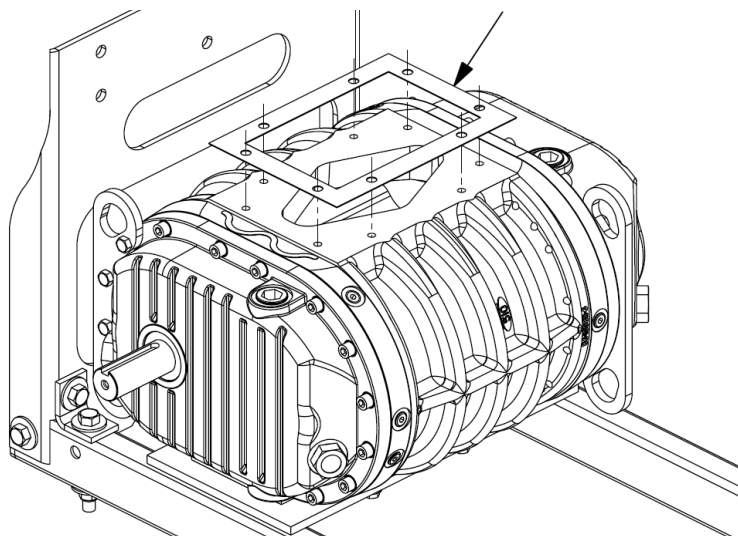
**Figure 5-15: Bearing mounting bolts**

- I. Install the V-belts onto the drive sheave.



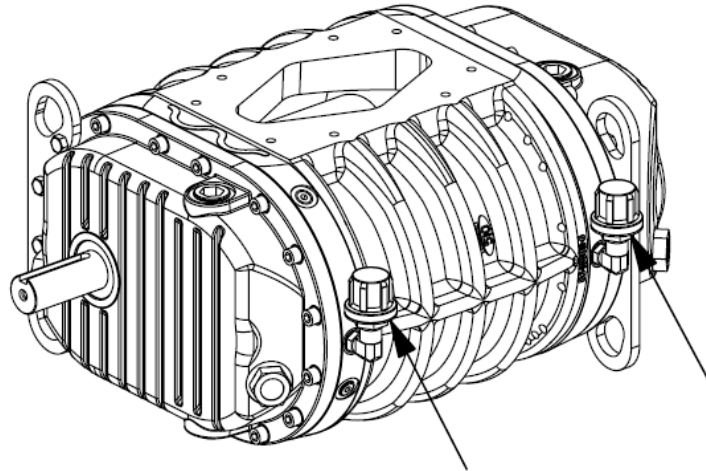
**Figure 5-16: Bearing mounting bolts**

- m. Refer to the auxiliary equipment's operator's manual to tension the belts and align the sheaves.
  - n. Rotate the pulley assembly by hand to ensure the blower rotates freely without binding and that the shaft is straight and aligned.
15. For PTO driven systems, proceed as follows, otherwise proceed to **Step 16**.
- a. Refer to the auxiliary equipment's operator's manual to install the PTO shaft.
  - b. Ensure the PTO output shaft and blower input shaft are parallel.
  - c. Ensure the true joint angle of the driveline falls within the permissible range.
  - d. Ensure the set screws are tightened to the required specification as detailed in the auxiliary equipment's operator's manual.
16. Align a new inlet gasket with the mounting holes of the blower casing inlet.

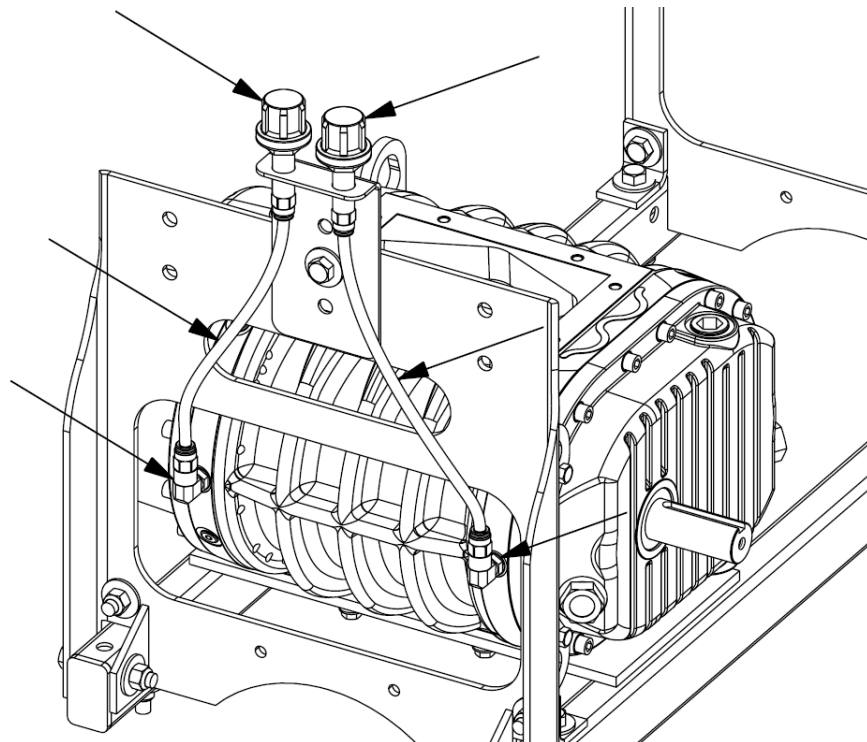


**Figure 5-17: Inlet mounting gasket**

17. Refer to the auxiliary equipment's operator's manual to install the inlet assembly. Ensure the inlet assembly is equipped with a vacuum relief valve as required.
18. Install two new breather assemblies in each headplate. Clean out any vent lines if equipped.



**Figure 5-18: Direct-mount breathers**



**Figure 5-19: Vent line breathers**

19. Proceed to *Initial Set-Up*.

## Initial Set-Up

To ensure safe and efficient operation, upon complete assembly and before initial use of the machine, perform the following inspections:

- Ensure the dust hazard analysis as required by NFPA 652 has been completed and the incorporation of the Walinga equipment complies with all relevant standards and regulations.
- Ensure the area is clear of any bystanders and individuals not involved in the operation of the machine, especially small children.
- To maintain proper stability, ensure all equipment is located on a flat surface that is solid, dry and clear of any other equipment. As applicable, engage the holding brake (if fitted), place wheel chocks, and anchor equipment securely.
- Ensure that any individuals involved in the operation of the machine or in close proximity to the machine are equipped with the required personal protective equipment as outlined in **Section 4: Safety**, including but not limited to: a hard hat, protective shoes with slip-resistant soles, protective glasses or goggles, heavy gloves, wet weather gear, and hearing protection. Long hair and loose clothing must be secured and jewelry should be removed to avoid personal injury as a result of coming into contact with moving or rotating components.
- Check to ensure all lubrication and grease points have been properly lubricated and the drive-end and idle-end oil reservoirs are filled to the correct level. Reference **Section 7: Maintenance and Adjustments** for detailed lubrication procedures and the required lubrication frequency.
- Check to ensure all guards are correctly positioned, closed and secured before operation to prevent any personal injury or damage. All guards must be closed and secured with fasteners before any operation.
- Ensure all mechanical locks, anchor chains, and any other transport devices that would hinder or prohibit the normal function or movement of the blower are removed. Serious damage to the machine and/or personal injury to the operator or bystanders may result from attempting to operate the machine while mechanical locking devices are attached.

## Break-In Inspections

During initial **installation**, after any **storage** period, after **maintenance / repair**, or after the blower has been **relocated** to a new position, the blower must be inspected. Be aware there may be additional break-in inspections required for auxiliary equipment; refer to the auxiliary equipment's operator's manual for required inspections and frequency. The inspections detailed below are to be performed after **each** of the aforementioned circumstances.

Upon initial operation of the blower:

1. Clear the area of all bystanders, especially small children.
2. Place all controls in neutral, stop and lock-out the power source, and wait for all moving parts to stop.
3. Inspect the blower and all inlet and outlet assemblies and conveying lines for any foreign material or debris and clean as required.
4. Refer to the auxiliary equipment's operator's manual to check the alignment of the drive system (belt drive and direct drive).
5. Check the drive-end and idle-end reservoir oil levels for proper lubrication. Too little oil will cause damage or failure of the bearings and gears; too much oil will result in overheating, causing damage to gears, bearings and other components. Refer to **Section 7: Maintenance and Adjustments** for oil level adjustment procedures.
6. Turn the drive shaft of the blower by hand to ensure the blower does not bind.
7. Jog the unit with the power source a few times to check the rotation and ensure the blower turns freely and smoothly.
8. Start the unit and operate for 15 minutes under no load. During this period, check for any developing hot spots or other indications of interference. If minor hot spots occur, introduce a small amount of lubricating oil into the blower inlet while it is operating. Repeat the lubrication as required until hot spots dissipate. Once all hot spots have been eliminated, it is not necessary to lubricate the inlet and impeller chamber for proper performance.
9. Operate the unit at approximately 2/3 load capacity until the blower is warmed.
10. Apply the full load to the system and observe the operation of the unit for half an hour. Check and monitor the blower frequently during the first day of operation to quickly identify any adjustment requirements.
11. If malfunctions occur, do not continue to operate the blower. Minor problems, such as knocking impellers, can cause serious damage or complete failure if the unit is operated without correction.
12. Make any adjustments as required.

After operating the blower for half an hour:

1. Clear the area of all bystanders, especially small children.
2. Place all controls in neutral, stop and lock-out the power source, and wait for all moving parts to stop.
3. Refer to the auxiliary equipment's operator's manual to check the alignment of the drive system (belt drive and direct drive).
4. Lubricate any drive couplings, as equipped.
5. Turn the drive shaft of the blower by hand to ensure the blower does not bind.
6. Check the drive-end and idle-end reservoir oil levels for proper lubrication. Refer to **Section 7: Maintenance and Adjustments** for oil level adjustment procedures.
7. Check for any developing hot spots or other indications of interference. If minor hot spots occur, introduce a small amount of lubricating oil into the blower inlet while it is operating. Repeat the lubrication as required until hot spots dissipate. Once all hot spots have been eliminated, it is not necessary to lubricate the inlet and impeller chamber for proper performance.
8. If malfunctions occur, do not continue to operate the blower. Minor problems, such as knocking impellers, can cause serious damage or complete failure if the unit is operated without correction.
9. Make any adjustments as required.

After operating the blower for five hours:

1. Repeat the inspections detailed for the first half hour.

After operating the blower for 10 hours:

1. Repeat the inspections detailed for the first half hour.

After operating the blower for 100 hours:

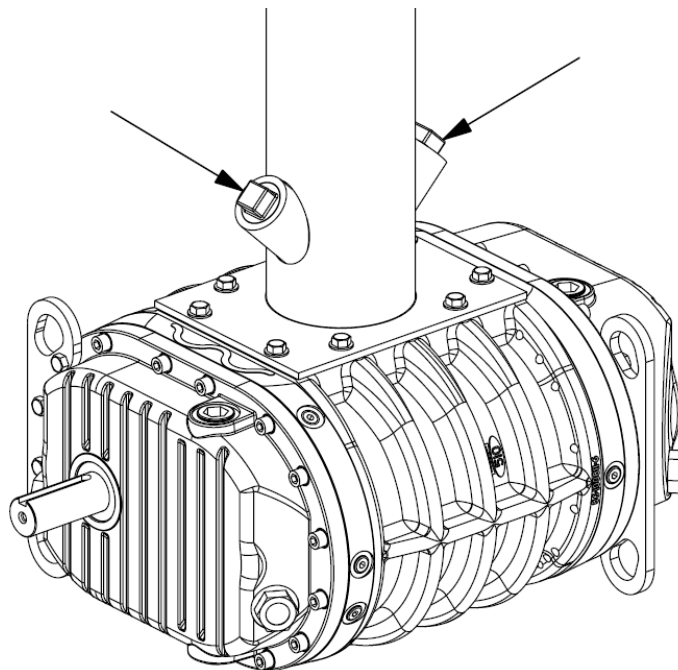
1. Drain and replace the oil in the drive-end and idle-end oil reservoirs. Afterwards, proceed with the specified oil change frequency detailed in **Section 7: Maintenance and Adjustments**.

## STORAGE

To prevent unnecessary down-time when preparing the blower for use after storage, it is important to carefully follow the storage preparation procedures.

To prepare the blower for storage, proceed as follows:

1. Clear the area of bystanders, especially small children.
2. Place all controls in neutral, stop and lock-out the power source, and wait for all moving parts to stop.
3. Thoroughly inspect the blower for any damaged or worn components; repair or replace any components as required before storage with reference to **Section 7: Maintenance and Adjustments** to prevent down-time upon use after storage.
4. Wash the blower thoroughly using a water hose or pressure washer to remove all dirt, dust, debris, and residue. The internal surfaces of the blower can be cleaned through flushing. To flush the internal surfaces, proceed as follows:
  - a. Operate the blower at a high idle for approximately 5 minutes to allow the blower to cool. Flushing a hot blower with a cooler liquid can damage the components.
  - b. Refer to the auxiliary equipment's operator's manual to position the blower outlet assembly or open an access point on the assembly to allow water to drain freely.
  - c. If equipped, remove the plugs from the wash-out ports of the blower inlet assembly. Otherwise, refer to the auxiliary equipment's operator's manual to gain access to the blower inlet.



**Figure 5-20: Inlet wash-out ports**

- d. Operate the blower at a high idle speed with the impellers rotating.
  - e. Allow clean water to enter the blower inlet access point for several minutes, allowing time for the water to wash out the casing interior, the impeller lobes, and the inlet and outlet assemblies.
  - f. Stop the water flow into the blower inlet and continue to run the blower for several minutes to allow all interior surfaces to completely dry.
  - g. When conveying materials with oily characteristics or high moisture content, including milled feeds, the blower may need to be flushed on a more regular basis to remove residue build-up. Oily residues may require flushing and soaking with a suitable solvent to dissolve build-up. Any non-food-grade solvents must be cleaned from the machine using hot water and/or detergent flushing. Ensure that any solvent used is acceptable for the intended market of the conveyed products.
5. Check to ensure all lubrication and grease points have been properly lubricated and filled with grease to remove any water residue from washing, and the drive-end and idle-end oil reservoirs are filled to the correct level with reference to **Section 7: Maintenance and Adjustments** for detailed lubrication procedures.
  6. Touch up all paint nicks and scratches to prevent rusting.
  7. If exposed, install a debris cover on the inlet and/or outlet to prevent accumulation of dirt, dust and debris and further limit rusting of the internal surfaces.
  8. Move the blower to its storage position. The storage position should be chosen as a location that is dry, level and free of debris, and does not have frequent human activity in the vicinity.

After storage, refer to **Section 7: Maintenance and Adjustments** and the above section *Break-In Inspections* to ensure all necessary maintenance tasks and inspections are completed. Once the required maintenance tasks have been completed, proceed to the standard pre-operation checks as outlined in **Section 6: Operation** and resume normal operation, performing all required inspections.

## END OF LIFE

Upon completion of the functional life of the blower, Walinga offers a rebuilding program as a cost-effective means of keeping your blower in optimal operating condition. Contact your Walinga dealer or representative to submit your blower and join the rebuild program.

Rebuilt and refurbished blowers feature:

- Complete disassembly, cleaning and inspection of all components
- Replacement of any components with excessive wear
- Re-machining and rebuilding of all components to bring to high factory standards
- New hard coating of all internal surfaces including casing, impellers, and headplates
- Dynamically re-balanced impellers
- Replacement of seals, gaskets, O-rings, and bearings as required
- Repainting of outer surfaces
- Assembly and adjustment to meet all clearance, timing and tolerance requirements

All rebuilt blowers are tested to ensure ideal operation and inspected for proper tolerances, clearances, and timing requirements.



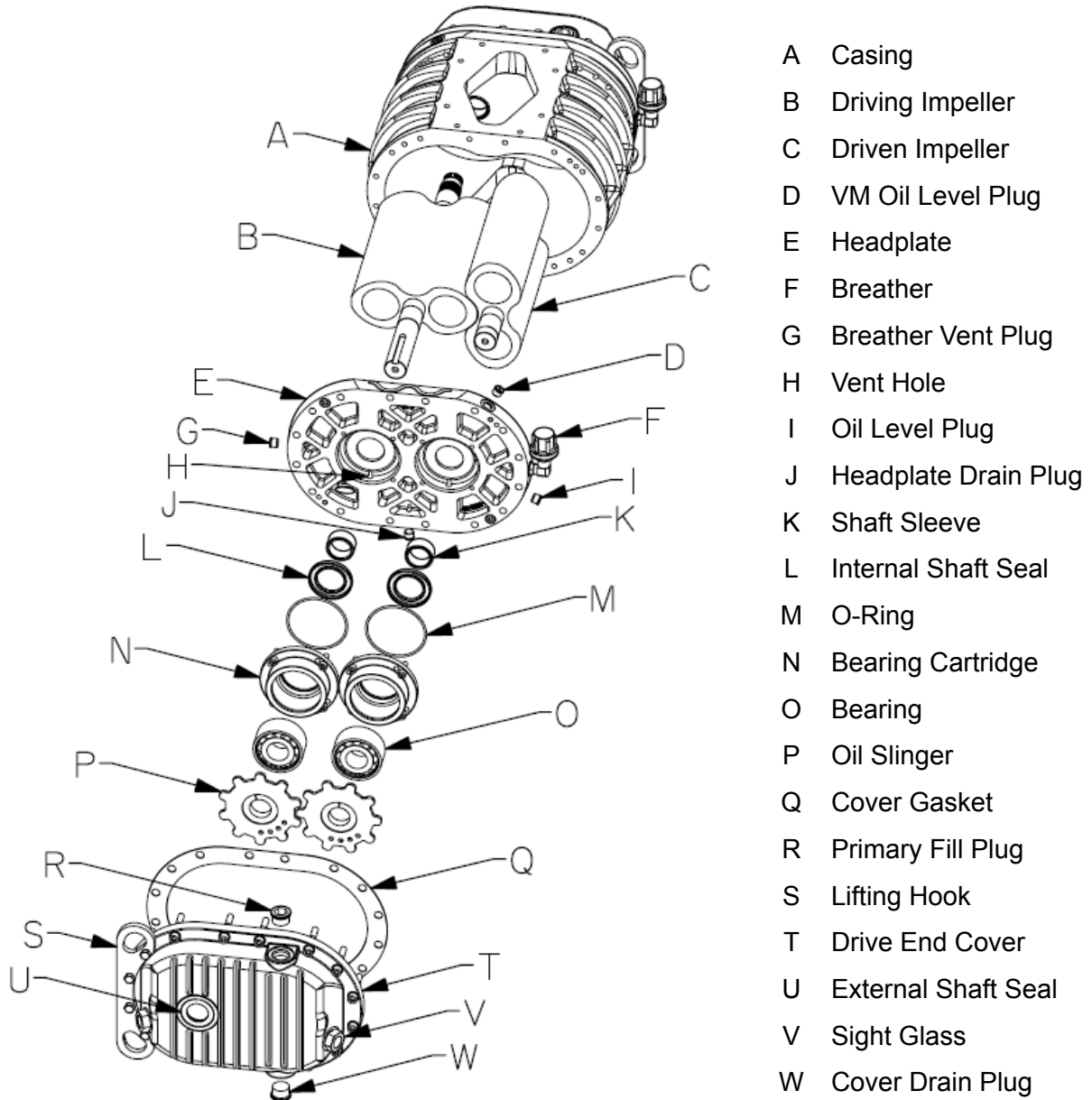
# Operation

---

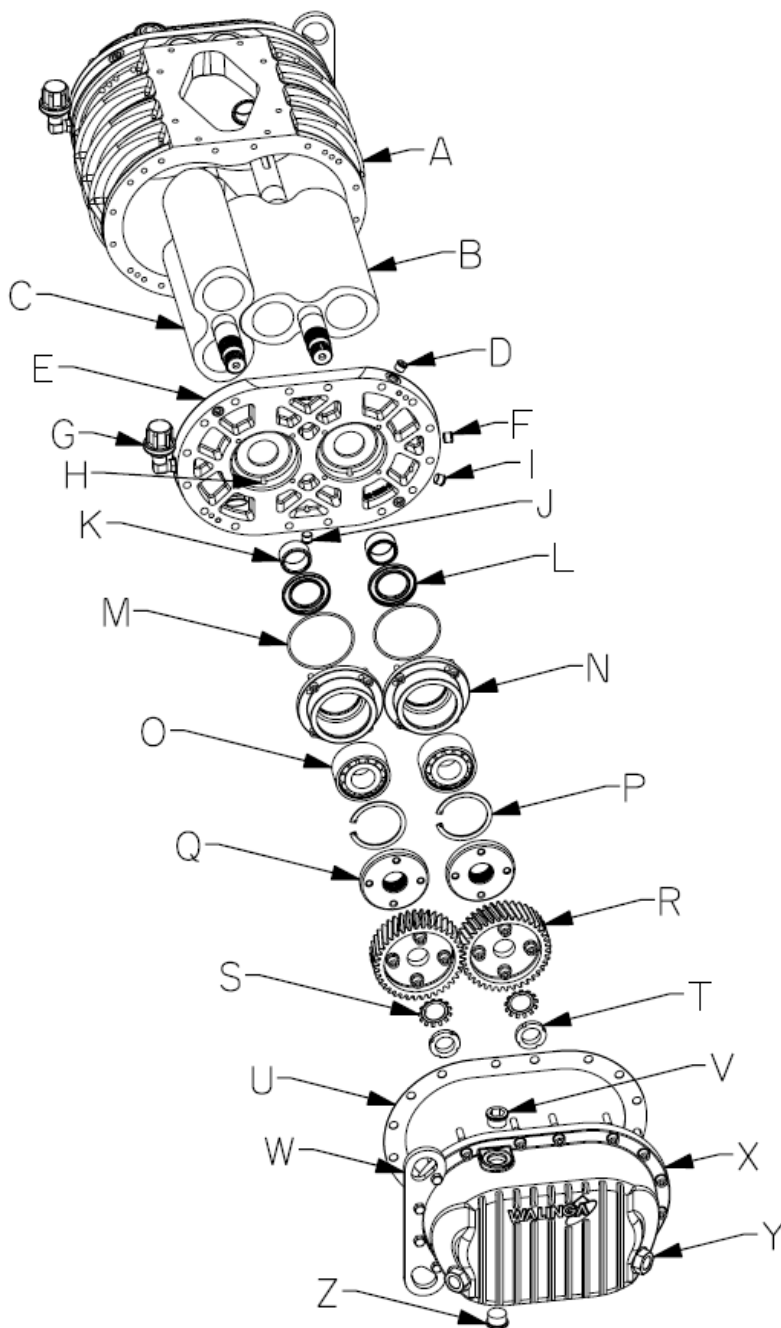
## BLOWER MODELS

---

**MACHINE FEATURES AND COMPONENTS**



**Figure 6-1: Blower drive end key components**



- A Casing
- B Driving Impeller
- C Driven Impeller
- D VM Oil Level Plug
- E Headplate
- F Breather Vent Plug
- G Breather
- H Vent Hole
- I Oil Level Plug
- J Headplate Drain Plug
- K Shaft Sleeve
- L Internal Shaft Seal
- M O-Ring
- N Bearing Cartridge
- O Bearing
- P Retaining Ring
- Q Timing Hub
- R Timing Gear
- S Lock Washer
- T Lock Nut
- U Cover Gasket
- V Primary Fill Plug
- W Lifting Hook
- X Idle End Cover
- Y Sight Glass
- Z Cover Drain Plug

**Figure 6-2: Blower idle end key components**

## CONTROLS AND DISPLAYS

Due to the wide range of applications in which a Walinga blower may be used, refer to the operator's manual of the auxiliary equipment for specific details pertaining to the controls and displays.

## OPERATION

### Pre-Operation Machine Preparation

For personal safety and to ensure the blower is in good mechanical condition, the following checks must be performed before operation of the blower:

1. Clear the area of bystanders, especially small children.
2. If operating for the first time after initial installation, storage period, maintenance/repair, or after moving the blower to a new location, follow the *Break-In Inspection* procedures outlined in **Section 5: Life-Cycle Procedures**.
3. Ensure the blower has been properly serviced and maintained as per the described methods and schedule outlined in **Section 7: Maintenance and Adjustments**.
4. Refer to the operator's manual of the auxiliary equipment to ensure the blower is sufficiently powered and connected to the drive system, and that the blower is properly connected to the pneumatic system.
5. Check the oil level in the oil reservoirs and adjust as necessary with reference to **Section 7: Maintenance and Adjustments**.
6. Ensure the blower rotates freely and is not obstructed and has not accumulated dirt, dust, or debris. Clean out the interior of the blower as necessary, ensuring the power source is properly disconnected and locked-out.
7. If equipped, inspect the muffler for any foreign material and ensure any materials have been removed. Failure to remove foreign materials may result in a fire hazard.
8. Ensure all mechanical locking devices, anchor chains, and transport or storage devices that would hinder or prohibit the normal function of the blower have been removed. Serious damage to the machine and/or personal injury to the operator or bystanders may result from attempting to operate the machine while mechanical locking devices are in place.
9. Close and secure all guards.

## Operation of the Machine

The operation procedures for the blower are heavily dependent on the auxiliary equipment. Refer to the operator's manual of the auxiliary equipment for operation procedures. The following are the general operating guidelines:

1. Clear the area of bystanders, especially small children.
2. Ensure the blower rotates freely in the correct direction as specified by the specific model and application. Operation of a blower without neutral timing in the reverse direction will result in high wear rates and component damage or failure.
3. Engage the drive system and allow the system to operate at 3/4 of the normal operating speed for a short period of time (~10 minutes) without introducing product to ensure the intake and discharge lines of the auxiliary equipment are empty and to allow the blower to warm. Conveying product with a cold blower can cause uneven expansion of components leading to damage or failure of the blower.
4. Introduce product to the system while operating the blower at 3/4 speed and gradually increase to the rated operational speed.
5. To operate at maximum capacity, monitor the discharge pressure gauge. The ideal pressure range for maximum capacity will vary greatly based on application and operating conditions; however, the pressure should never exceed 15 psi (103 kPa). Refer to the auxiliary equipment's operator's manual to make adjustments to the system to achieve the ideal discharge pressure.
6. If equipped, monitor the movement of the product through sight windows. At maximum capacity, the window may be covered by the product, but the product should not be stationary.
7. If equipped, monitor the vacuum gauge. The pressure range for maximum capacity will vary based on the application and operating conditions; however, the vacuum pressure should never exceed -16 in Hg (-54 kPa).

## Stopping the Machine

The stopping procedures for the blower are heavily dependent on the auxiliary equipment. Refer to the operator's manual of the auxiliary equipment for stopping procedures. The following are the general stopping guidelines for normal operation:

1. Once product has been stopped from entering the conveying system, allow the blower and system to continue to operate for a short period of time (~30 seconds) to allow all components and conveying lines to completely empty.
2. To stop the blower, refer to the auxiliary equipment's operator's manual for specific instructions, The general stopping principles are as follows:
  - For PTO and belt driven blowers, slow the rotational speed of the drive power source to a low idle, disengage the PTO/clutch, and stop the power source.
  - For hydraulically driven blowers, move the control lever for the blower to the center *STOP* position.
  - For electrically driven blowers, press the button on the control panel labeled *STOP*.
3. With reference to **Section 7: Maintenance and Adjustments**, review the maintenance schedule and perform any required maintenance on the blower.
4. Proceed to prepare the blower for storage or transportation with reference to **Section 5: Machine Life-Cycle Procedures**.

In emergency situations, for example, if the safety of a person is threatened, it may be necessary to immediately shut-down the blower. To avoid potential damage to the blower and other components, the following should only be used in an emergency situation. Refer to the operator's manual of the auxiliary equipment for any special emergency shut-down procedures.

To shut-down the blower in an emergency:

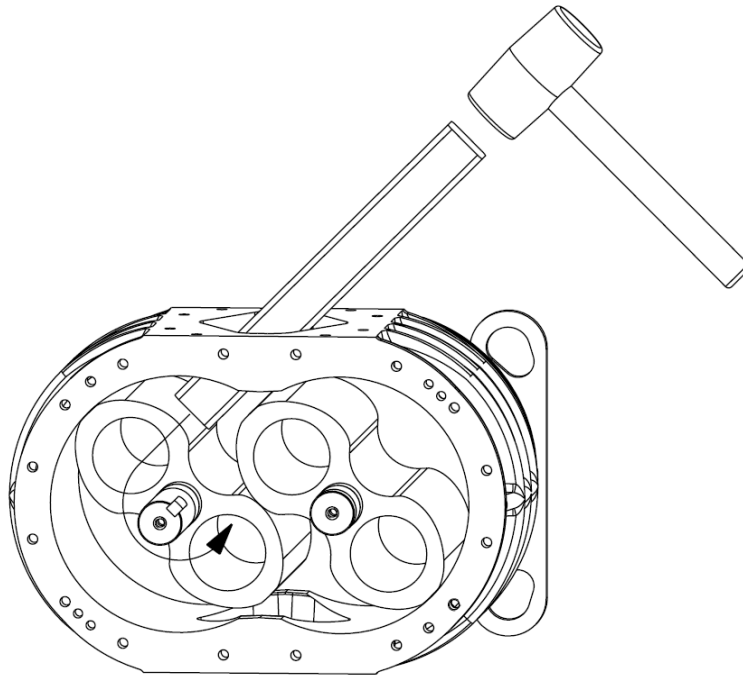
- For PTO and belt driven blowers:
  - Disengage the PTO/clutch.
- For hydraulically driven blowers:
  - Move the control lever for the blower to the center *STOP* position.
- For electrically driven blowers:
  - Press the button on the control panel labeled *KILL*, **or**
  - Rotate the power disconnect switch of the blower to the *OFF* position.

## Clearing Blockages

To clear a blockage from a blower, proceed as follows:

1. **DO NOT** open any access point or reach into the blower to clear an obstruction while in operation.
2. **DO NOT** attempt to dislodge an obstruction with the drive system.
3. If the blockage occurs during operation, refer to the auxiliary equipment's operator's manual to stop and shut-down the blower and auxiliary equipment. It is important that the product flow into the system is stopped to prevent any further obstructions.
4. Ensure all controls are in neutral and the power source is stopped and locked-out.
5. Refer to the auxiliary equipment's operator's manual to gain access to the inlet and outlet of the blower.
6. Examine the interior of the blower to attempt to identify the obstruction. The two most common obstructions can be identified as follows:
  - Debris blockage: typically occurs during operation, it may result if the system is overloaded and product is drawn into the inlet of the blower.
  - Residue blockage: typically prevents the start-up of the blower, it may result due to dust (such as polymers) or residue (such as oilseeds) entering the blower at high operational temperatures which then solidify and form a hard coating when the blower cools after operation.
7. For a debris blockage, proceed as follows:
  - a. Reach into the blower and attempt to remove the obstruction by hand. Do **NOT** use any tools to attempt to dislodge the obstruction, doing so may cause damage to the blower impellers or casing. If the obstruction clears, proceed to **Step 10**.
  - b. Rock the driving impeller by rotating the input shaft by hand in a forward and reverse direction to attempt to dislodge the obstruction. Do **NOT** use any tool (such as a pipe wrench) to rotate the shaft, doing so may cause the shaft to bend resulting in significant damage. If the obstruction clears, proceed to **Step 10**.
  - c. Apply a solvent approved for use in accordance to the regulations of the industry of the conveyed product to the interior surfaces of the blower. Allow some time, typically between 2 hours up to 24 hours, for the solvent to soak the surfaces of the blower. If the obstruction clears, proceed to **Step 10**.
  - d. Refer to **Section 7: Maintenance and Adjustments** to disassemble the blower. Remove the obstruction and soak any components in an approved solvent as required.
  - e. Reassemble the blower with reference to **Section 7: Maintenance and Adjustments**. The bearings, seals and gaskets must be replaced if the blower is disassembled. Proceed to **Step 10**.

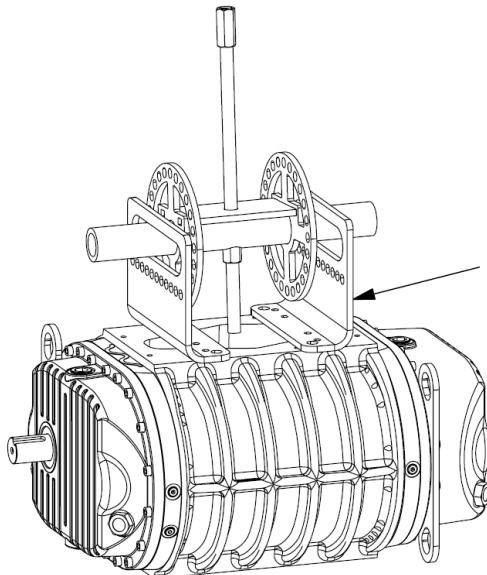
8. For a residue blockage, proceed as follows:
  - a. Apply a penetrating oil to the surfaces of the impellers, headplates and casing. Ensure the chosen penetrating oil complies with any restrictions of the industry of the conveyed product, if not, precautions must be taken to ensure the oil is properly cleaned and removed from all surfaces of the blower.
  - b. Allow the penetrating oil to sit on the surfaces, typically 2 hours up to 24 hours.
  - c. Attempt to rotate the input shaft by hand, rocking the shaft in a forward and reverse direction to assist with dislodging any remaining residues. If the obstruction clears, proceed to **Step 10**.
  - d. Insert a cushioning block, such as a 2" x 2" hardwood plank, into the inlet or outlet of the blower and position it against the lobe of the impeller. Do not use a softwood plank as it will shatter; do not use steel as it will mar the impeller.
  - e. Strike the cushioning block with a mallet to dislodge and break the impellers free from the residue coating. If the obstruction clears, proceed to **Step 10**.



**Figure 6-3: Dislodging impellers with cushioning block**

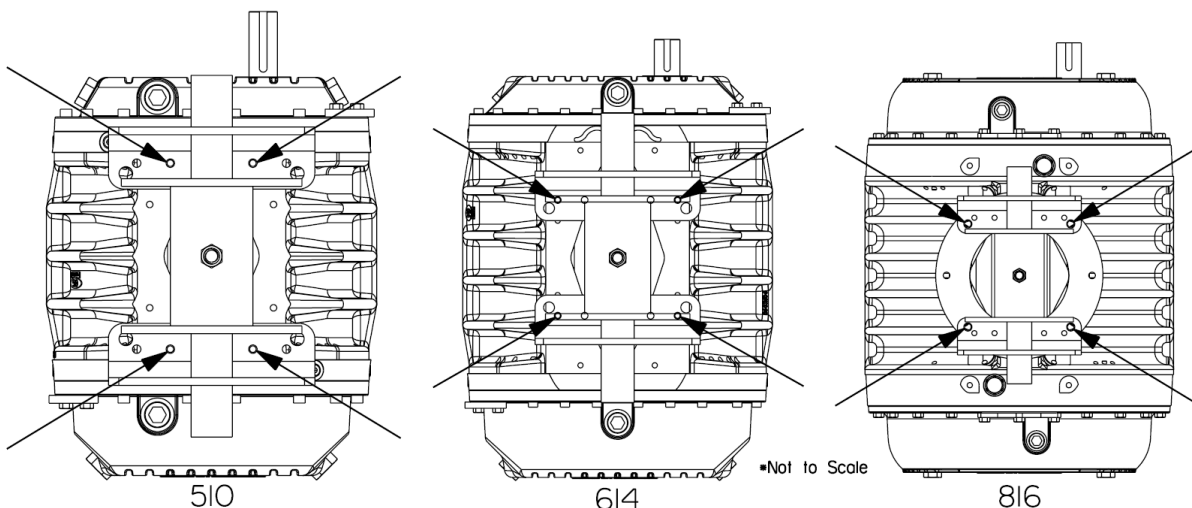
- f. Refer to **Section 7: Maintenance and Adjustments** to disassemble the blower. Remove the obstruction and soak any components in an approved solvent or penetrating oil as required.
- g. Reassemble the blower with reference to **Section 7: Maintenance and Adjustments**. The bearings, seals and gaskets must be replaced if the blower is disassembled. Proceed to **Step 10**.

9. Walinga's Blower Unjamming Tool (50-157877-5) may be used to dislodge debris and residue blockages. To utilize the tool, proceed as follows:
  - a. Position the unjamming assembly on the surface of the blower. The unjamming tool may be positioned on the inlet or outlet surface of the blower depending on the location of the blockage and positioning of the lobes. To prevent damage to the internal surfaces, the blower should be unjammed by rotating the impellers in the direction that will clear the obstruction with the smallest rotation, this may be in the normal or reverse operational direction.



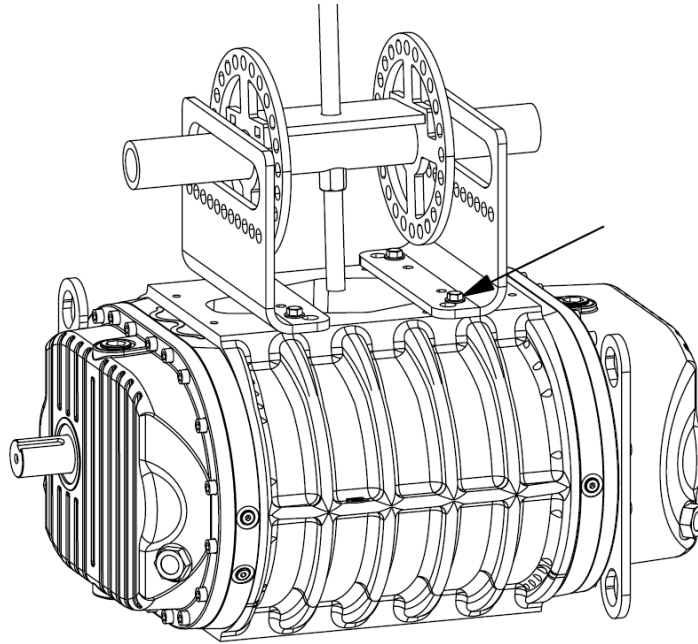
**Figure 6-4: Positioning of unjamming tool**

- b. Align the appropriate holes in the mounting bracket with the holes of the casing.



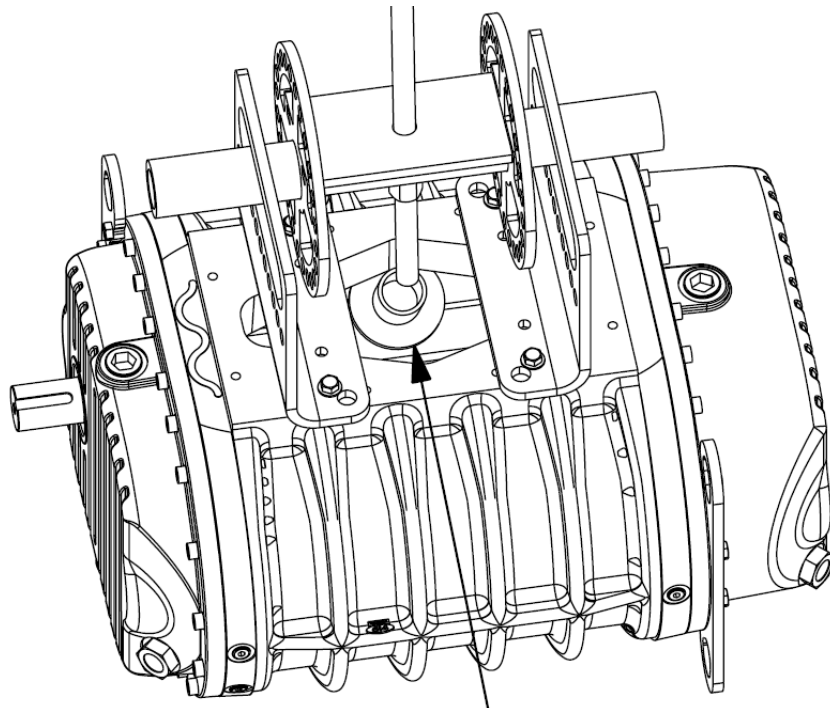
**Figure 6-5: Mounting bracket hole positioning**

- c. Secure the unjamming tool to the blower with the required fasteners.



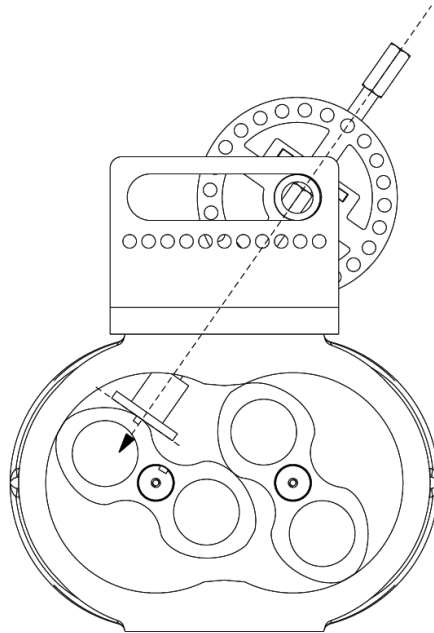
**Figure 6-6: Unjamming tool securement**

- d. Insert the ram pad into the blower and position it against the impeller lobe.



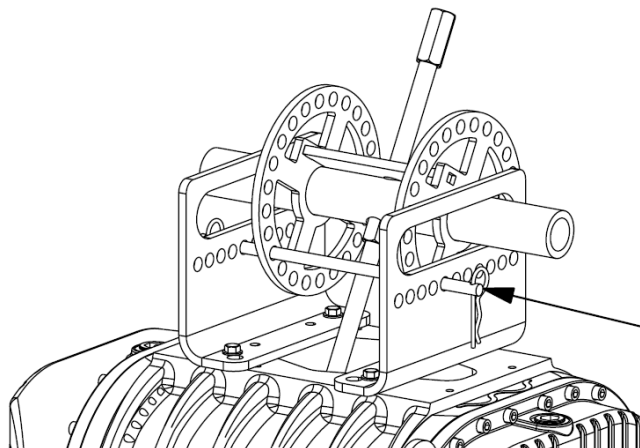
**Figure 6-7: Ram pad positioning**

- e. Slide and rotate the assembly as required to align the threaded rod with the ram pad. The ram pad must be positioned to apply force perpendicular to the lobe.



**Figure 6-8: Rotating assembly alignment**

- f. Secure the rotating assembly in place with the locking shaft and pins.



**Figure 6-9: Rotating assembly securement**

- g. Tighten the threaded rod until the ram pad is held securely against the impeller.
- h. Using an impact wrench, drive the threaded rod against the ram pad and impeller until the impeller is broken loose from the obstruction.
- i. Loosen and remove the mounting bracket fasteners and remove the unjamming tool. Ensure the ram pad is also removed. Proceed to **Step 10**.

10. Refer to the flushing procedures detailed in **Section 5: Machine Life-Cycle Procedures**. All solvents, penetrating oils, debris, and residues must be removed from the blower.
11. Inspect all components for any sign of damage. Any component showing signs of damage must be repaired or replaced.
12. Rotate the input shaft by hand, ensuring the impellers rotate smoothly.
13. Refer to the auxiliary equipment's operator's manual to reinstall any inlet or outlet assemblies that were removed. Ensure all guards are installed and secure.
14. Follow standard operating procedures to jog the blower several times, listening for any impeller knocking or abnormal noises. Do **NOT** operate the blower if the impellers knock, doing so will cause severe damage.
15. Resume normal operation.

## OPERATING TIPS AND HINTS

To achieve the best performance from your blower keep the following in mind:

- Keep intake lines as full as possible for maximum capacity.
- For vacuum applications, maximum capacity is achieved when using large diameter conveying lines. Only use the smaller rubber lines for final clean-up.
- Position the blower and route the lines to minimize the number of bends and corners. If a corner is necessary, use a large radius elbow.
- Keep the conveying lines as short as possible to minimize friction losses.
- If long distance moving is required, try positioning the blower to decrease the length of vacuum lines and increase the length of pressure lines. Use solid metal tubing whenever and wherever possible.
- Keep the clearance and timing of the impellers within the range outlined in **Section 7: Maintenance and Adjustments**, to achieve maximum efficiency.
- Keep all components properly lubricated, and the oil reservoirs properly filled to ensure smooth operation of the blower.
- In cold conditions, where the ambient temperature is lower than -38 °F (-39 °C), the blower oil will not flow freely and lubrication of the mechanical components will be limited. Therefore, it is necessary to start the blower slowly, running at an idle with no load until the blower has warmed to a temperature of 32 °F (0 °C).
- For blowers installed on mobile equipment, allow the blower to cool after operation before transporting in cold weather. Rapid cooling of a blower can cause the blower to freeze up or form condensation.
- Keep the operating temperature of the blower below the maximum operating temperatures as detailed in **Section 7: Maintenance and Adjustments**.

## TROUBLESHOOTING

Reference **Table 6-1** for assistance with some of the most common issues, causes and solutions that you may face during the operation of your blower. If you encounter a problem that is difficult to solve, even after having referenced the following table and the troubleshooting guide of any auxiliary equipment's operator's manual, please contact your Walinga dealer or representative. Before you call, please have your operator's manual and your blower's serial number ready and available.

For detailed procedures for the solutions, reference **Section 6: Operation** and **Section 7: Maintenance and Adjustments**.

**Table 6-1: Troubleshooting for blowers**

SYMPTOM	PROBLEM	CAUSE	SOLUTION
Blower is overheating	Insufficient airflow	Air restriction in the system	Increase the air intake
			Clean or replace filters, screens or mufflers as required
			Straighten lines and reduce the number of elbows used
	Insufficient airflow	Excessive pressure differential	Check inlet and outlet pressures and compare with recommended conditions, identify cause of discrepancy and correct as required
			Adjust speed to pressure ratio to required specifications
	Insufficient airflow	Incorrect line size	Use larger diameter intake or discharge lines
		Insufficient lubrication	Blower oil level is too low
	Resistance in blower drive gears	Blower oil level is too high	Reduce oil level as required
	Resistance inside blower casing	Product build up inside the blower	Flush and clean out the interior of the blower
	Gear case insufficiently vented	Improperly installed or blocked headplate vents	Inspect and clean vents and breathers, ensure correct installation, replace as required
Drive system fault	Drive system is misaligned	Realign the drive system as required	
Internal damage to the blower	Blower impellers are rubbing	Contact your Walinga dealer / service provider	

SYMPTOM	PROBLEM	CAUSE	SOLUTION
Decreased system capacity	Insufficient airflow	Air restriction in the system	Increase the air intake
			Clean or replace filters, screens or mufflers as required
			Straighten lines and reduce the number of elbows used
		Incorrect blower speed	Adjust speed to meet required specifications
	Check for slipping belts or loose couplings, adjust as required		
	Air leaks in the system	Incorrect air to product ratio	Reduce air intake or increase product intake
		Vacuum or pressure relief valve is stuck open	Clean, repair or replace relief valves as required
		Loose connections in the lines	Tighten all connections
		Required seals or covers are loose or not installed	Install, close and secure all seals and covers required
		Damaged seals or gaskets	Replace all damaged or worn seals
	Air is bypassing inside the blower	Excessive clearances between the blower lobes and casing	Repair or replace blower
	Malfunction of relief valves	Improper installation of relief valves	Inspect vacuum and pressure relief valve for proper installation and function, repair or replace as required
		Valve failure	Clean, repair or replace relief valves as required
	Excessive resistance in lines	Transfer distance is too long	Keep transfer distance as short as possible, reposition equipment as necessary
		Too many bends or elbows	Straighten lines and reduce the number of elbows used
Obstruction in the lines		Clear obstruction from the lines	

SYMPTOM	PROBLEM	CAUSE	SOLUTION
Excessive noise	Impellers knocking	Unit out of time	Check timing of blower and retime as required
		Distortion due to improper mounting or shaft strains	Check drive system alignment and adjust as necessary
			Relieve any shaft strain
		Excessive pressure differential	Check inlet and outlet pressures and compare with recommended conditions, identify cause of discrepancy and correct as required
	Impellers knocking in open and/or closed position	Worn timing gears caused by improper lubrication or overloading	Replace the timing gears
		Worn bearings	Replace bearings, inspect bearing cartridges for any damage and replace as required
System exceeds relief pressure	Loss of airflow	Defective pressure relief valve	Clean, repair or replace the pressure relief valve
		Product flow blockage	The discharge destination is full
	Insufficient airflow	Obstruction in the discharge line	Clear obstruction from the discharge line
		Improper ratio of air to product	Increase air intake or reduce product intake
		Too many bends or elbows	Straighten lines and reduce the number of elbows used
Product is being damaged	Air leaks in the lines	Loose connections in the lines	Tighten all connections
		Damaged seals or gaskets	Replace all worn or damaged seals
		Worn or damaged conveying lines	Replace any worn or damaged lines or elbows
	Excessive air speed	Blower is running too fast	Reduce the blower speed
		Improper air to product ratio	Reduce air intake or increase product intake

SYMPTOM	PROBLEM	CAUSE	SOLUTION
Drive system failure	Shaft failure	Excessive overhung load	Replace input shaft, relieve any overhung loads
	Gradual motor overloading	Clogged filter or muffler	Clean or replace filters, screens or mufflers as required
		Incorrect installation of relief valves	Inspect vacuum and pressure relief valves for proper installation and function, repair or replace as required
		Excessive line loss	Measure pressure differential directly across the blower. Adjust as required
	Sudden motor overloading	Excessive pressure in system	Inspect pressure relief valve for proper function, repair or replace as required
	Inspect lines for obstructions, clear as required.		
Excessive component wear	Excessive end clearance wear	Misaligned drive system	Properly align drive system
	Excessive bearing or gear wear	Improper lubrication	Check and adjust oil level of reservoirs as required
			Inspect oil for any contamination, replace as required
			Check oil lines/strainer for obstructions in force feed units
	Oil too light	Replace oil with Walinga Super Duty Blower Oil	
Pulsation in the lines	Insufficient airflow	Air restriction in the system	Increase air intake
			Clean or replace filters, screens or mufflers as required
			Straighten lines and reduce the number of elbows used
		Blower speed is too low	Adjust speed to meet required specifications
			Check for slipping belts or loose couplings, adjust as required
Excessive pressure differential	Check the inlet and outlet pressures and compare with the recommended conditions, identify cause of discrepancy and correct as required		



# Maintenance and Adjustments

---

BLOWER MODELS

---



## MAINTENANCE SAFETY

Unsafe workshop and servicing practices increase the risk of injury around machinery. Review the following safety guidelines for important information regarding safety involved with maintenance operations.

- Read, understand and follow all operating, maintenance and safety information in the operator's manual.
- Clear the area of bystanders, especially small children, when carrying out any maintenance or repairs or making any adjustments.
- Place all controls in neutral, stop and lock-out the power source, and wait for all moving parts to stop before servicing, adjusting or maintaining.
- Follow good shop practices:
  - a. Keep the service area clean and dry.
  - b. Ensure electrical outlets and tools are properly grounded.
  - c. Use adequate lighting for the job at hand.
- Use only tools, jacks and hoists of sufficient capacity for the job.
- Keep hands, feet, hair, and clothing away from all moving and/or rotating parts.
- Ensure all guards are in place and properly secured upon completion of maintenance.

## COMPLETE DISASSEMBLY AND ASSEMBLY PROCEDURES

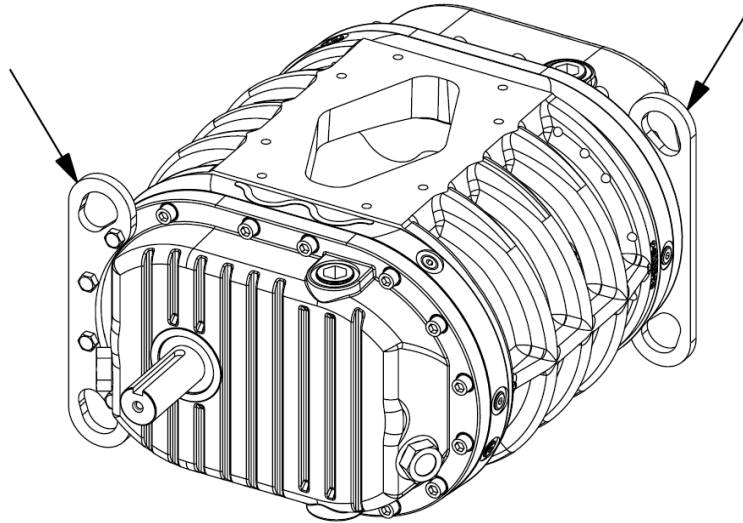
### Blower Disassembly

To inspect, repair components, replace components or adjust the clearances, it may be necessary to partially or completely disassemble the blower.

To disassemble the blower, proceed as follows:

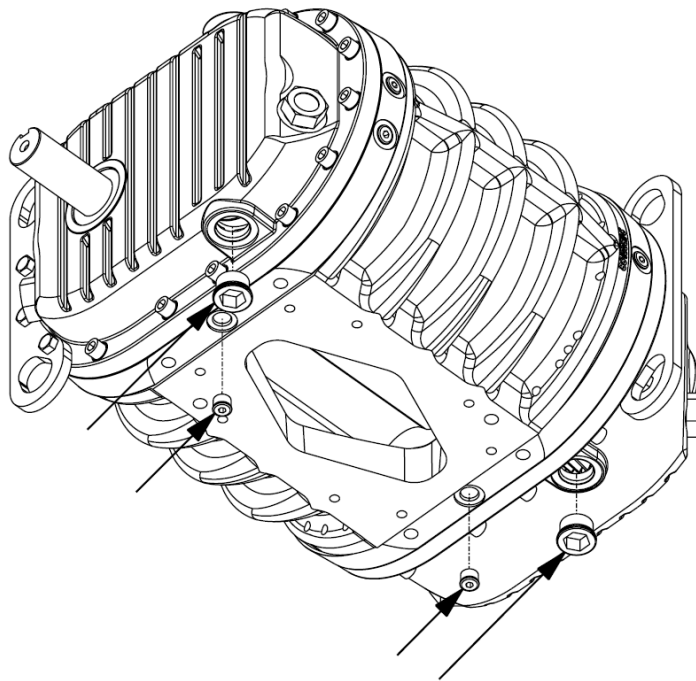
1. Clear the area of all bystanders, especially small children.
2. Ensure all controls are in neutral, and the power source is stopped and locked-out.

3. Refer to the auxiliary equipment's operator's manual to disconnect the blower from the drive system, remove any inlet and outlet assemblies and remove the blower from its mounting position. Use the lifting hooks to move the blower to a clean work area.



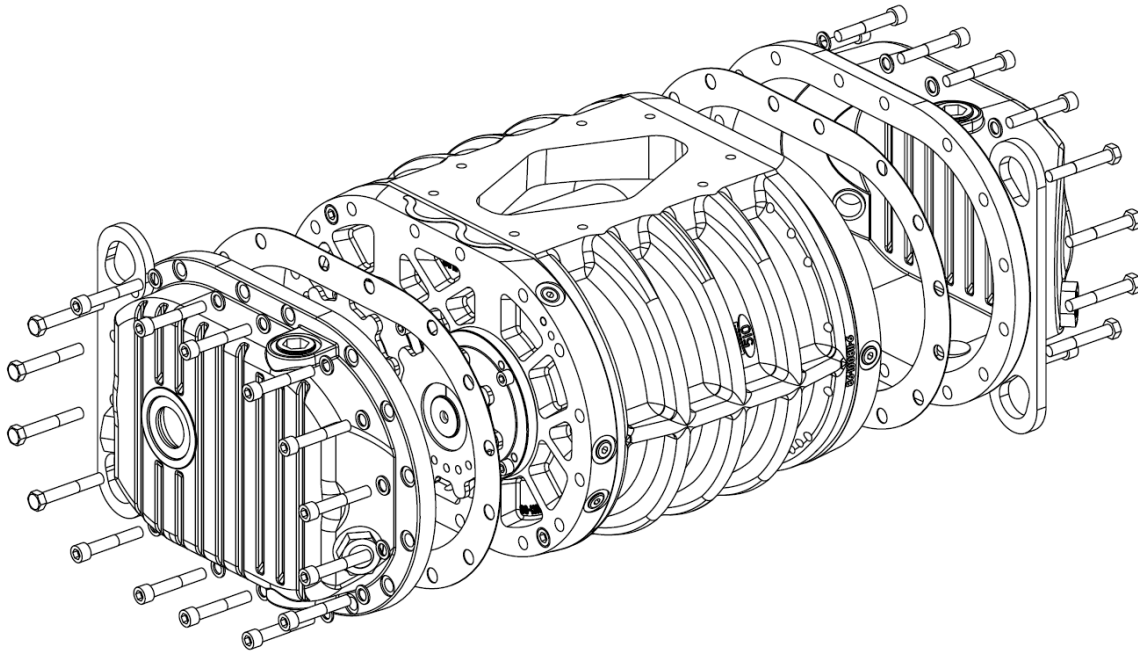
**Figure 7-1: Blower lifting hooks**

4. Position a collection pan or pail below the blower to catch the waste oil.
5. Remove the drain plug(s) from the drive and idle end headplates, covers and adapter if equipped. Allow the oil to drain from the reservoirs into the receptacle.



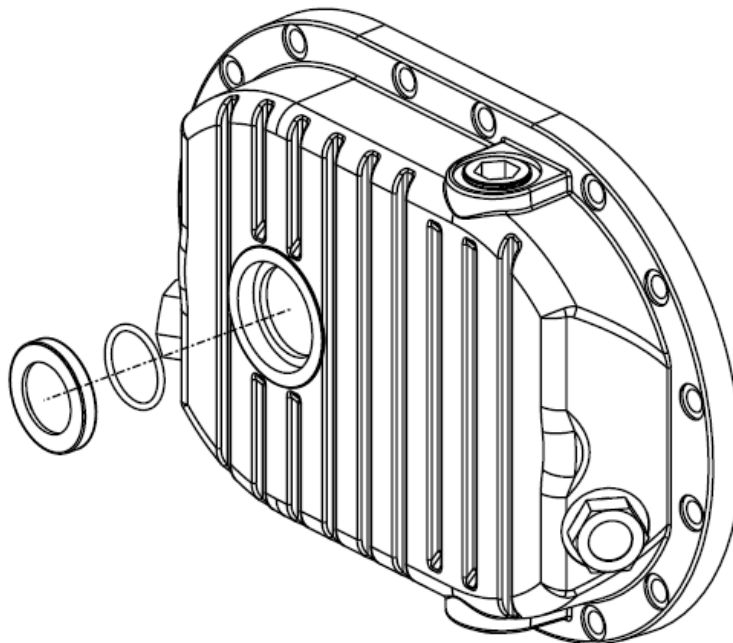
**Figure 7-2: Oil drain plug removal**

6. Loosen and remove the fasteners securing the drive end and idle end covers in place and remove both covers and gaskets.



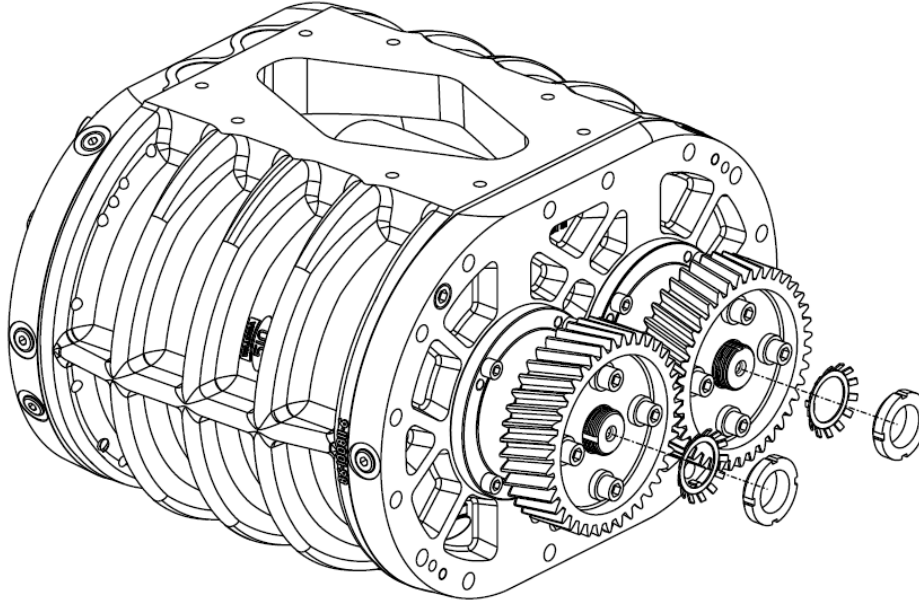
**Figure 7-3: Cover removal**

7. Remove the shaft seal(s) and O-ring if equipped from the drive end cover.



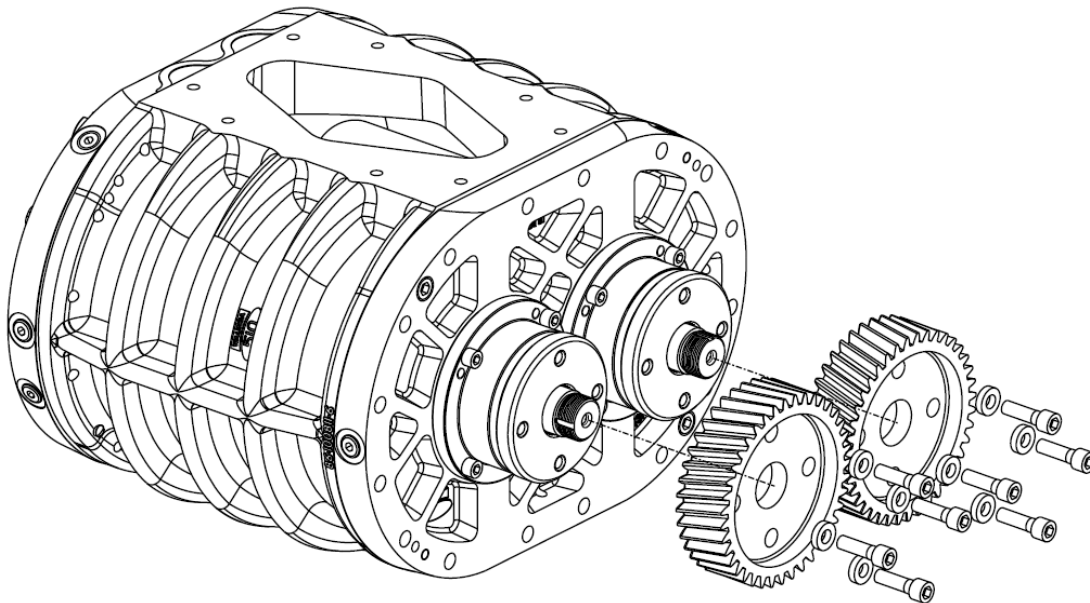
**Figure 7-4: Shaft seal and O-ring removal**

8. For **506**, **510** and **614** models only:
  - a. At the idle end, unbend the lock washer tabs from the lock nuts and remove the lock nuts and lock washers from both impeller shafts.



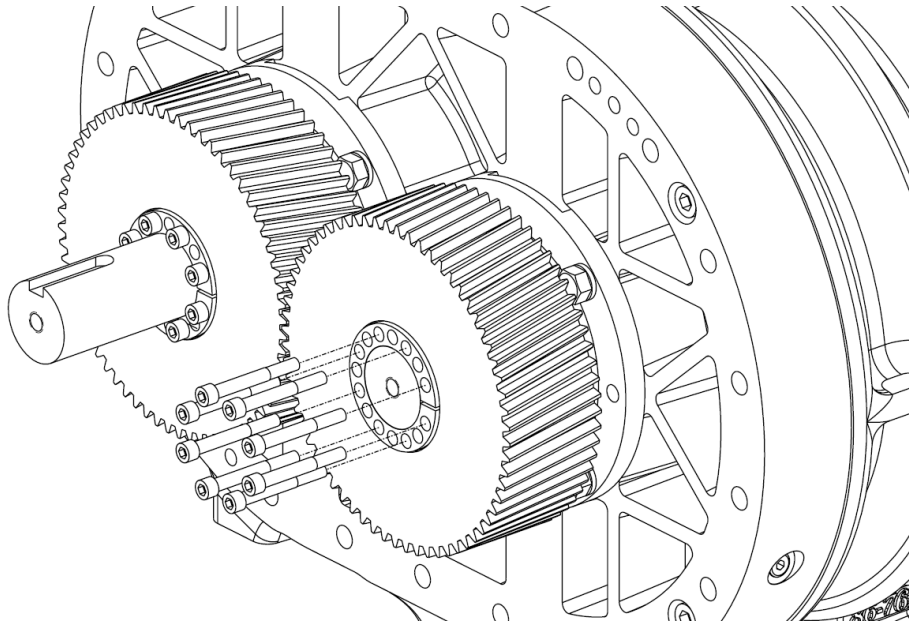
**Figure 7-5: Lock nut and lock washer removal**

- b. Loosen and remove the fasteners securing the timing gears. Match the timing gears and lift both gears off the timing hubs simultaneously. Use care to not damage the gears.



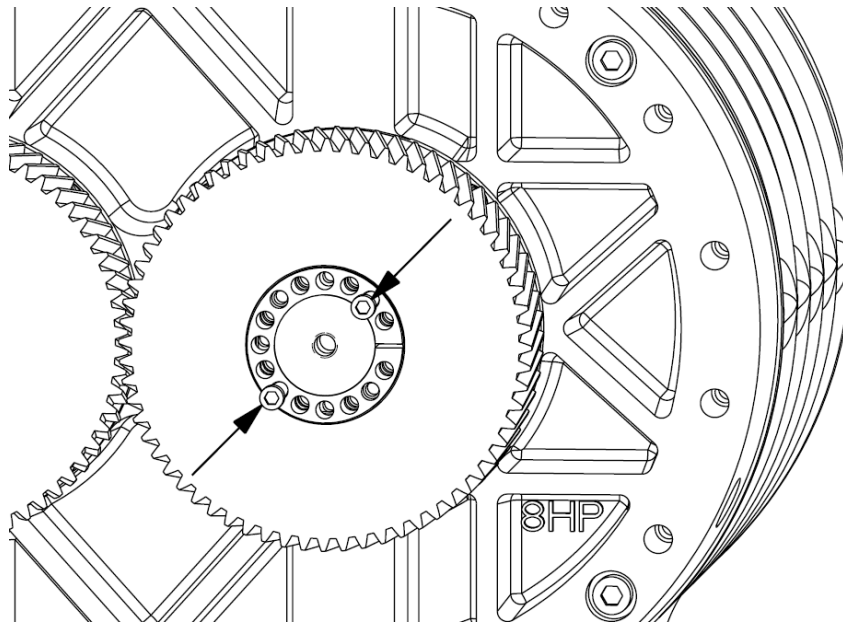
**Figure 7-6: Timing gear removal**

9. **816 and 1020 models only:**
  - a. Remove the locking screws from one locking bushing.



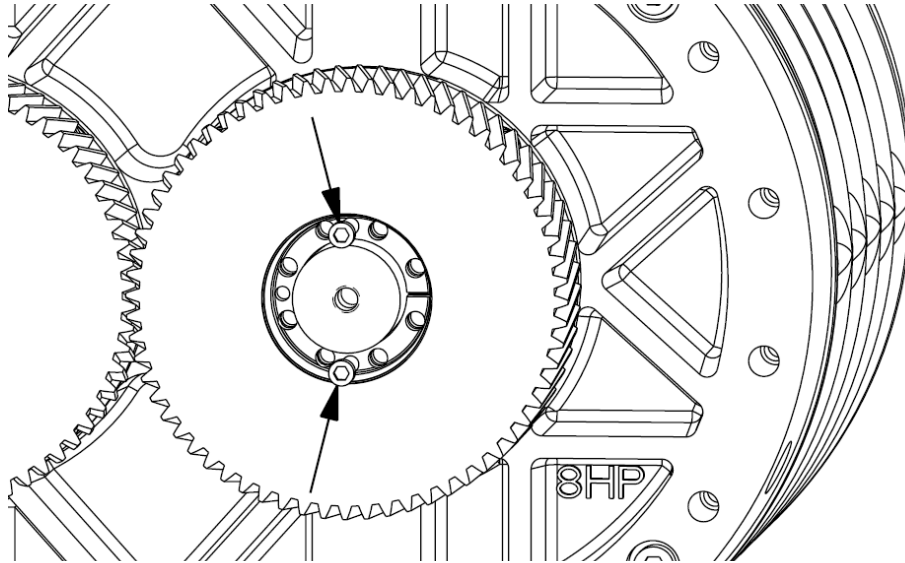
**Figure 7-7: Locking screw removal**

- b. Insert two locking screws into the push-off threads (correct holes will appear the shallowest) of the outer collar and progressively tighten the screws until the outer collar is released. Remove the outer collar.



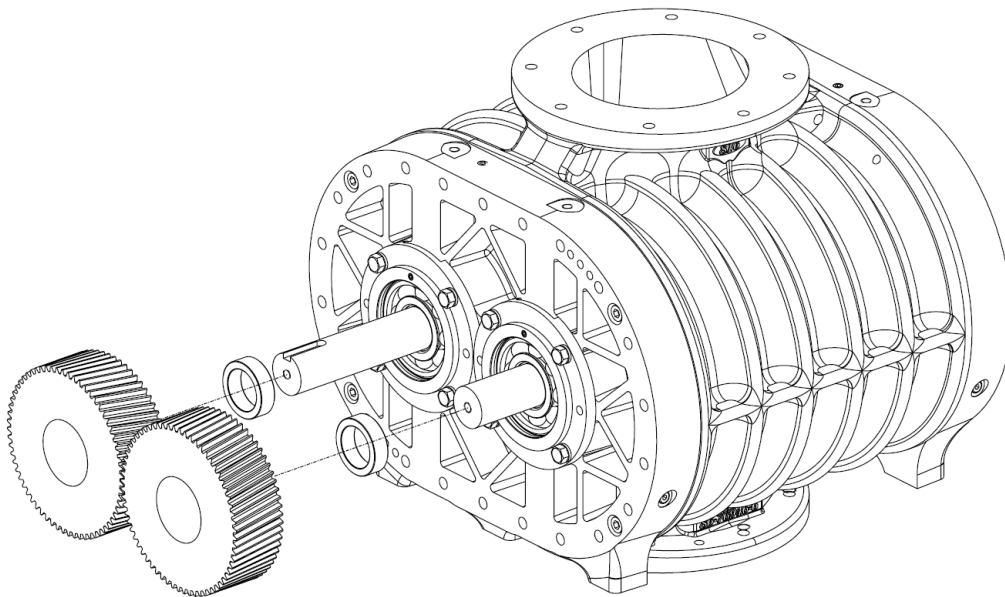
**Figure 7-8: Outer collar removal**

- c. Transfer the two locking screws into the push-off threads of the center collar. Progressively tighten the screws until the center collar is released from the inner collar. Remove the center and inner collars from the shaft.



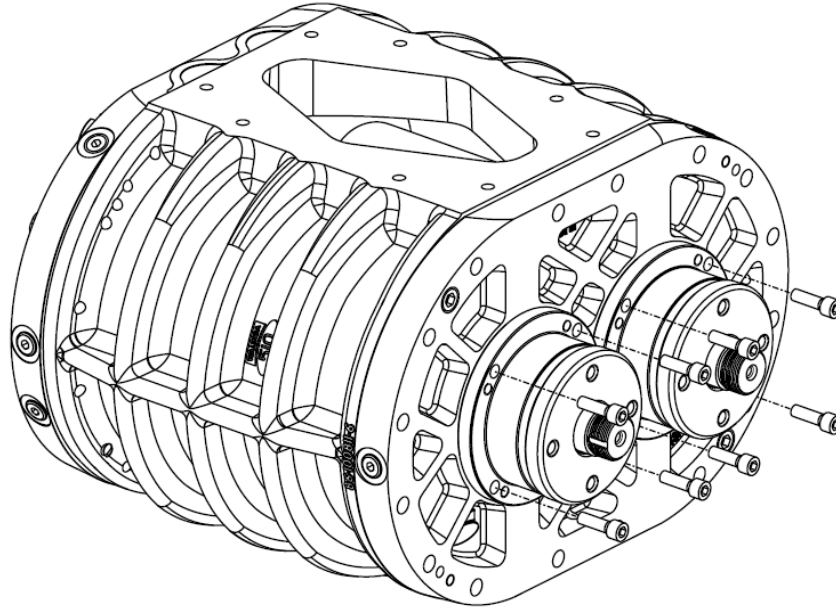
**Figure 7-9: Locking bushing removal**

- d. Reassemble and loosely reinstall the locking screws into the locking bushing to maintain its original configuration.
- e. Repeat **Step 9a** through **Step 9d** for the second locking bushing.
- f. Remove the timing gears and gear spacers from the impeller shafts.



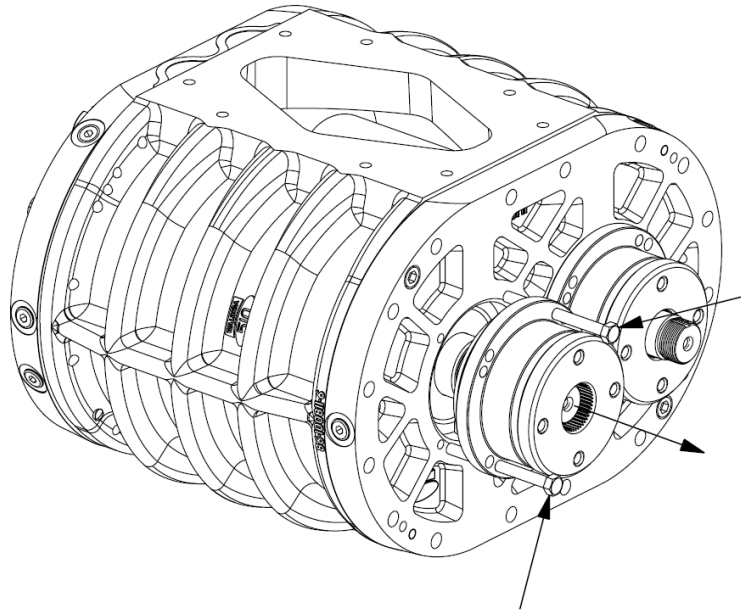
**Figure 7-10: Timing gear and spacer removal**

10. Loosen and remove the fasteners from the exposed bearing cartridges.



**Figure 7-11: Bearing cartridge fastener removal**

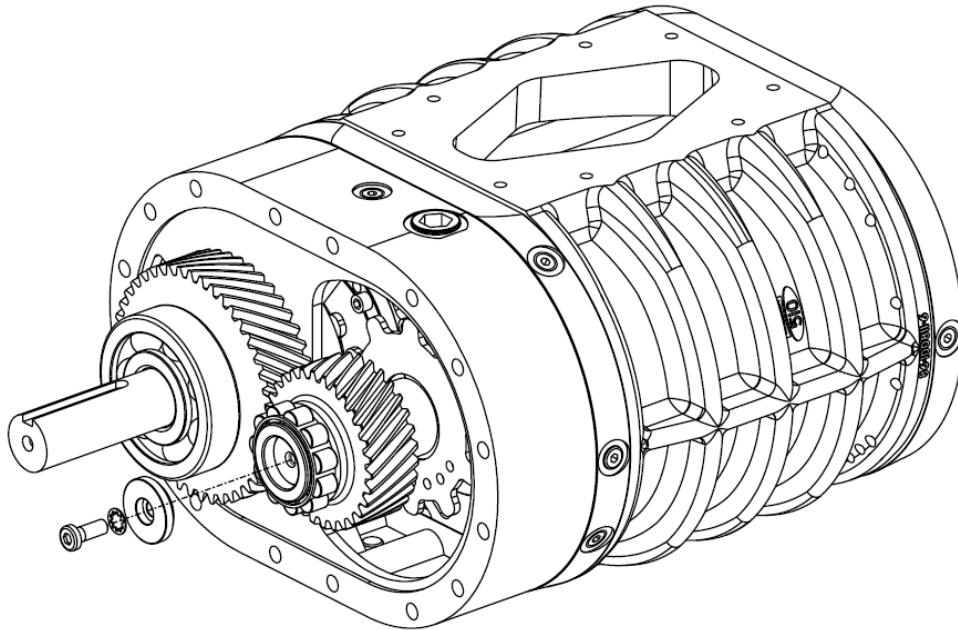
11. Install two bolts, at least 3 in (25.4 mm) in length in the threaded holes of the first bearing cartridge. Evenly tighten the two bolts to remove the bearing cartridge assembly and timing hub, if equipped, from the impeller shaft. Repeat to remove the second bearing cartridge assembly and timing hub.



**Figure 7-12: Bearing cartridge removal**

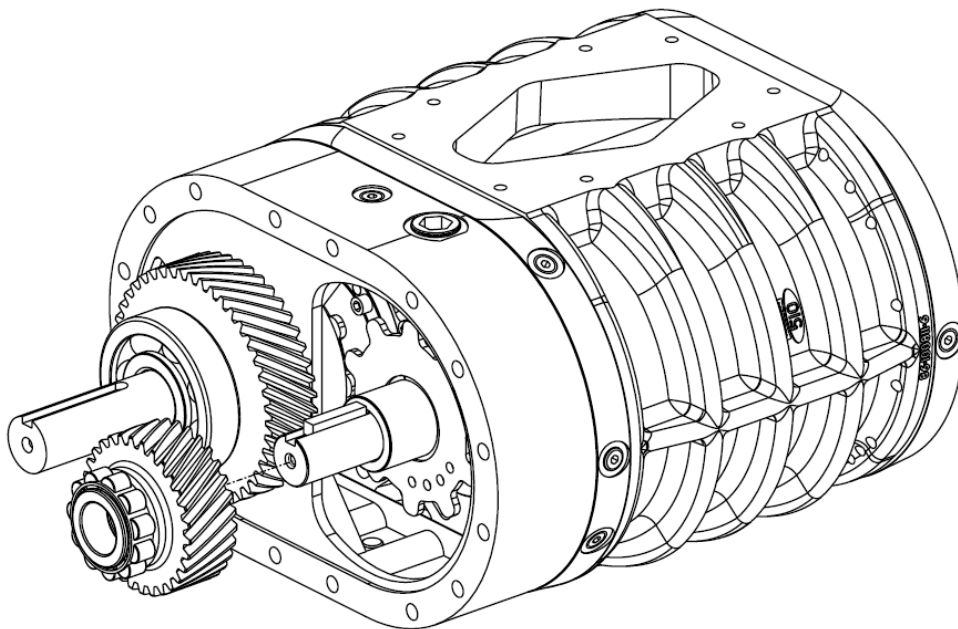
**12. Gear Head blowers only:**

- a. Remove the cap screw and retainer plate from the impeller shaft.



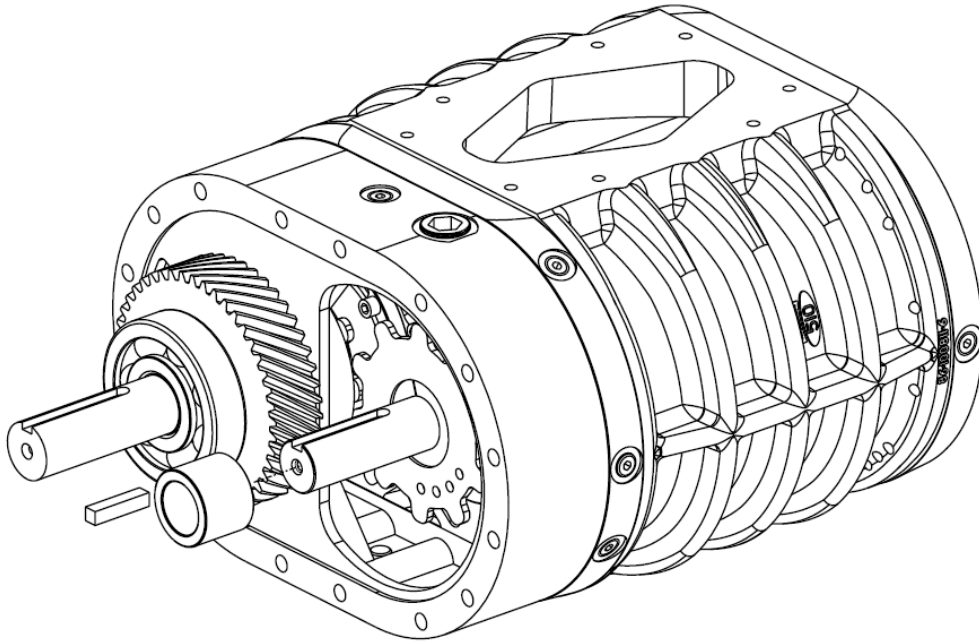
**Figure 7-13: Retainer plate removal**

- b. Using a gear puller, remove the pinion gear and bearing from the impeller shaft in one operation.



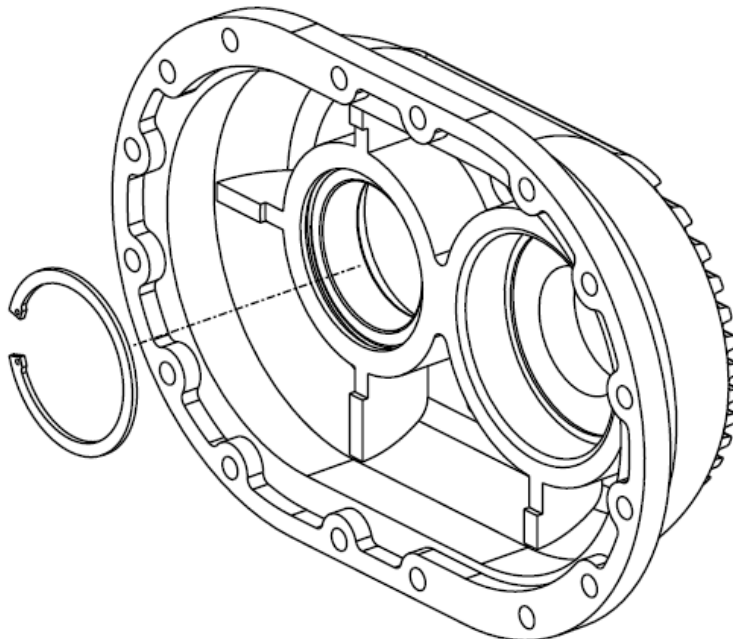
**Figure 7-14: Pinion gear and bearing removal**

- c. Remove the pinion gear key and gear spacer.



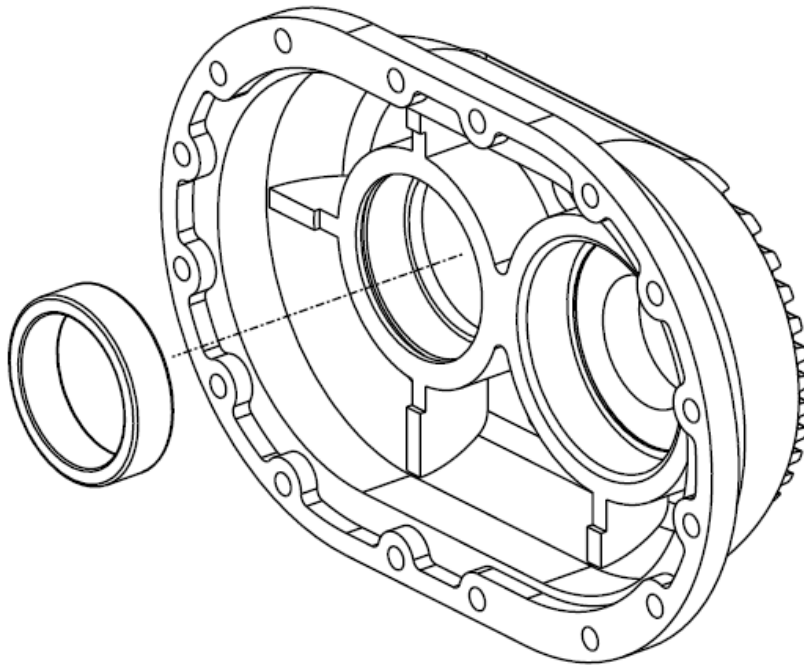
**Figure 7-15: Pinion gear spacer and key removal**

- d. Remove the retaining ring from the cover.



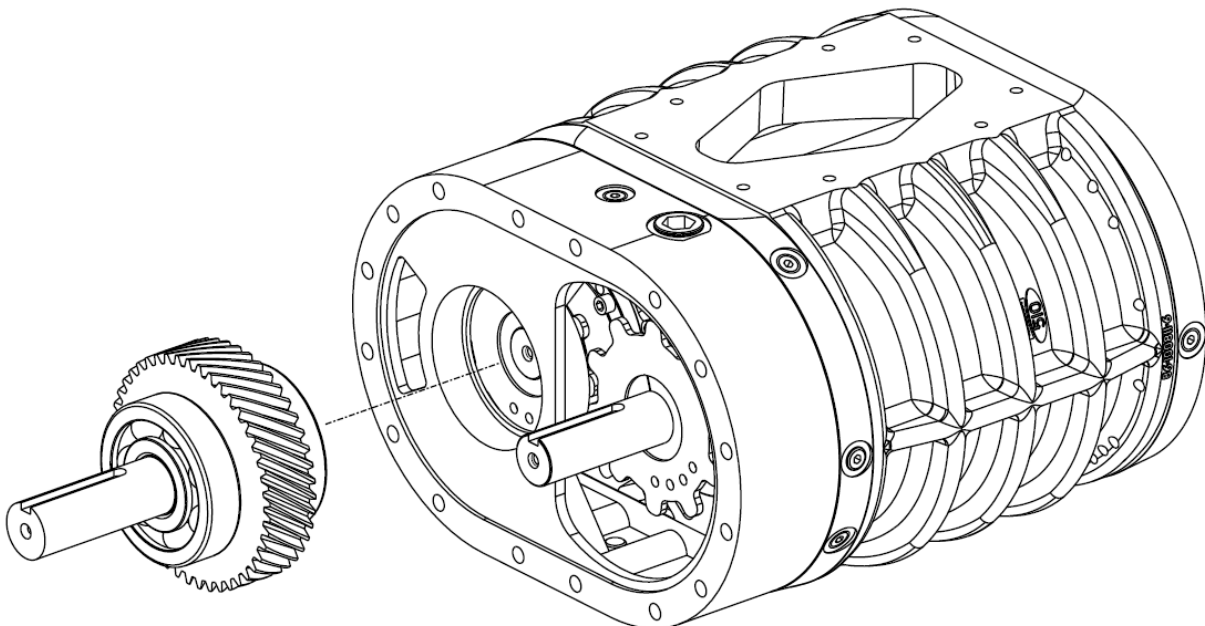
**Figure 7-16: Retaining ring removal**

- e. Using a gear puller, remove the outer race of the bearing from the cover.



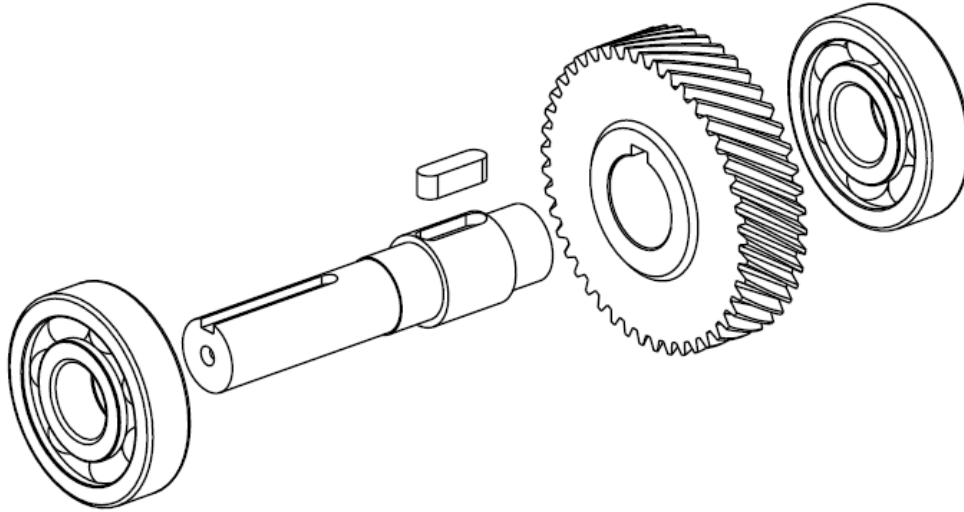
**Figure 7-17: Bearing outer race removal**

- f. Remove the input shaft assembly from the adapter.



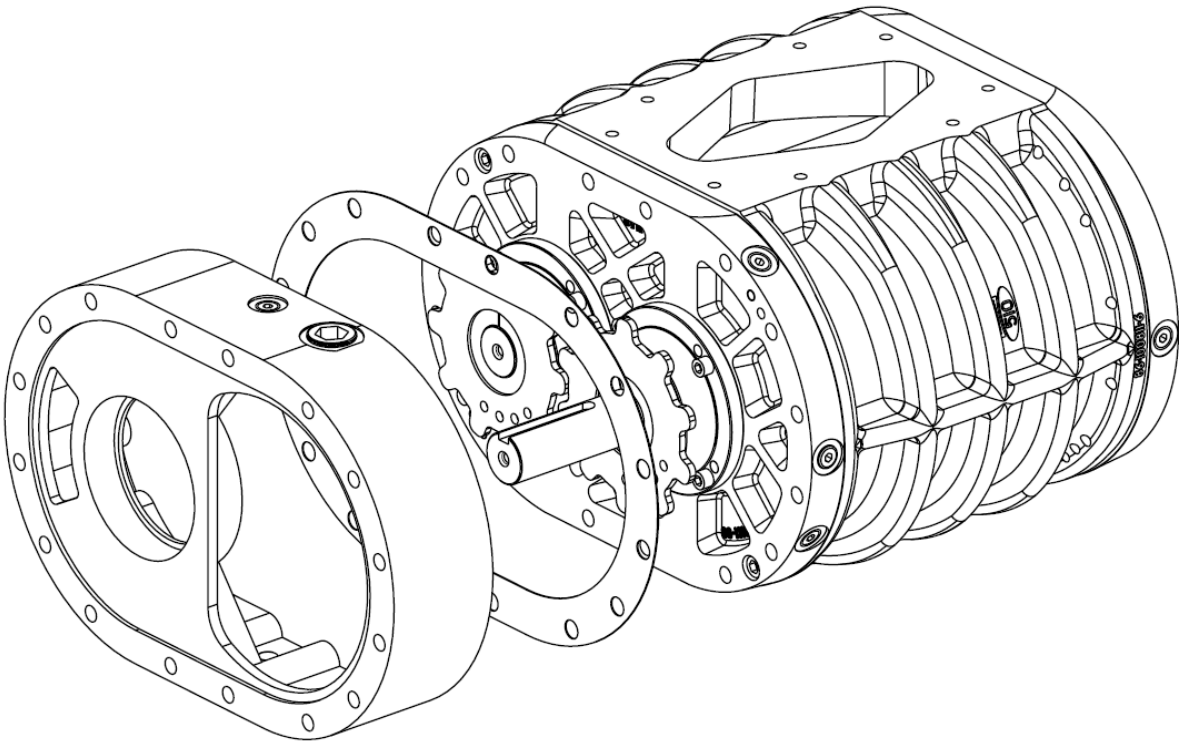
**Figure 7-18: Input shaft assembly removal**

- g. Use a press with a support on the gear surface to drive the input shaft out of the gear and bearing. Reverse the shaft assembly and press the input shaft from the second bearing.



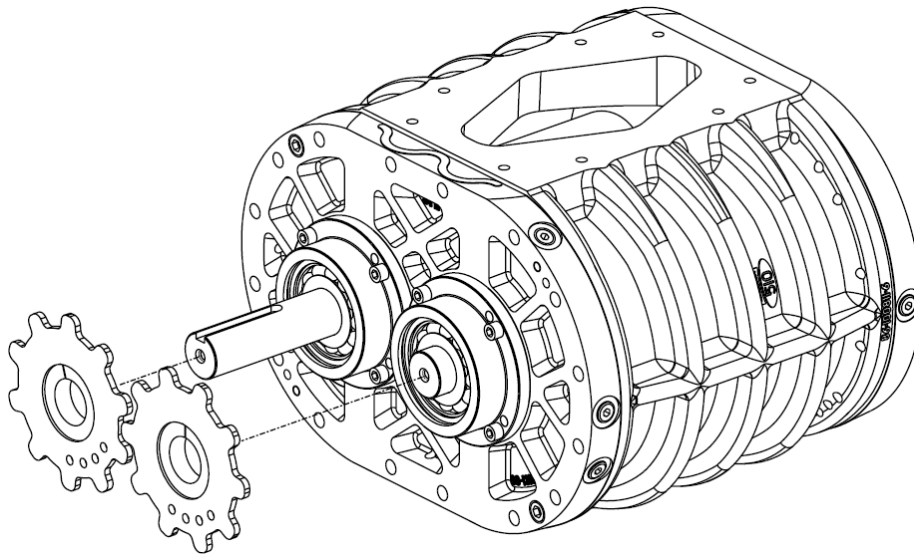
**Figure 7-19: Disassembly of input shaft**

- h. Remove the adapter and gasket.



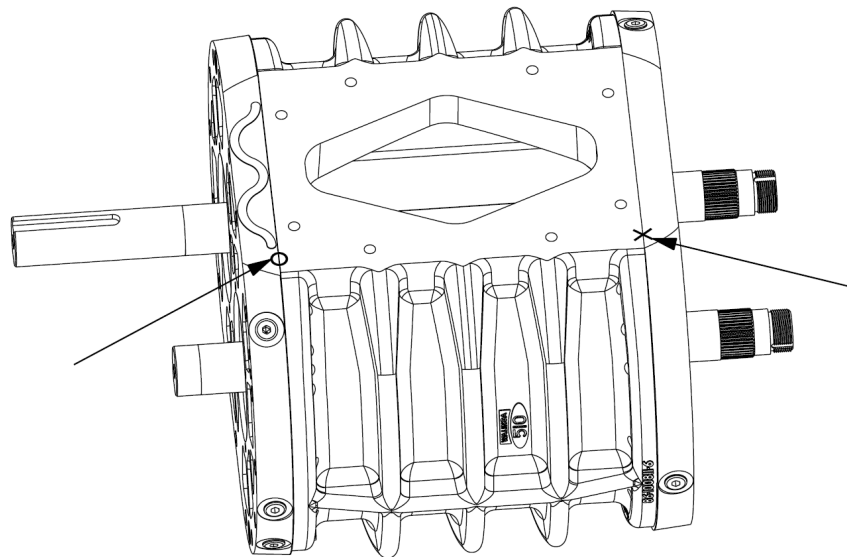
**Figure 7-20: Adapter and gasket removal**

13. Loosen the fasteners of the oil slingers and remove the oil slingers from the impeller shafts.



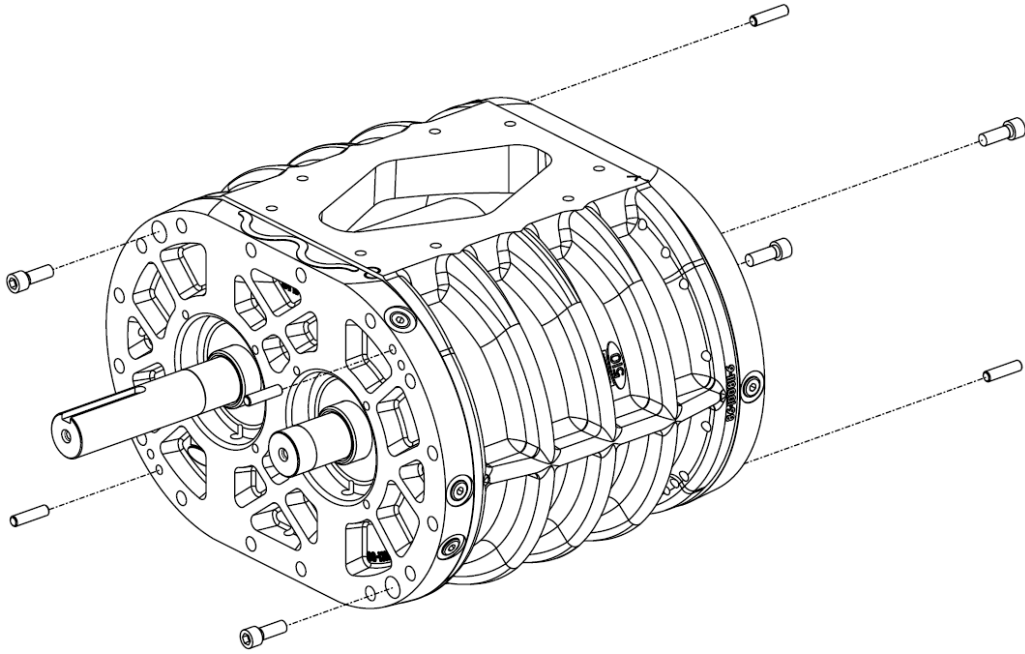
**Figure 7-21: Oil slinger removal**

14. Repeat **Step 10** through **Step 11** to remove the remaining bearing cartridges.
15. Disassemble all bearing cartridge assemblies including: retaining rings, bearings, shaft seals, and O-rings.
16. Mark the position of each headplate relative to the casing on the top surface. Ensure the marks are differentiable, either by colour, shape or position, to ensure the headplates are installed on the correct end of the casing in the correct orientation.



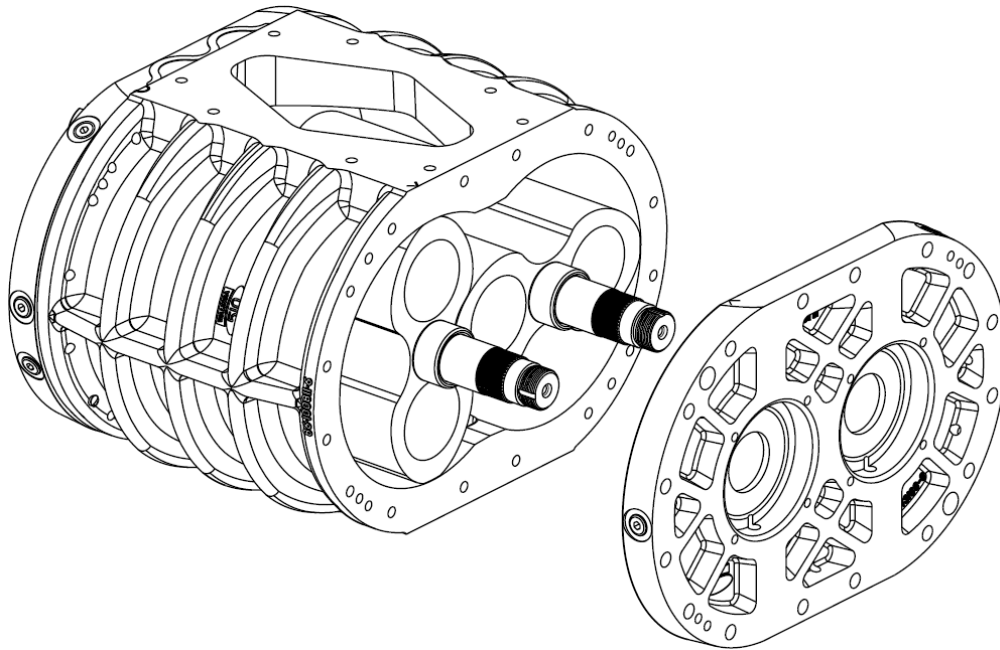
**Figure 7-22: Headplate position marking**

17. Remove the cap screws and dowel pins from each headplate.



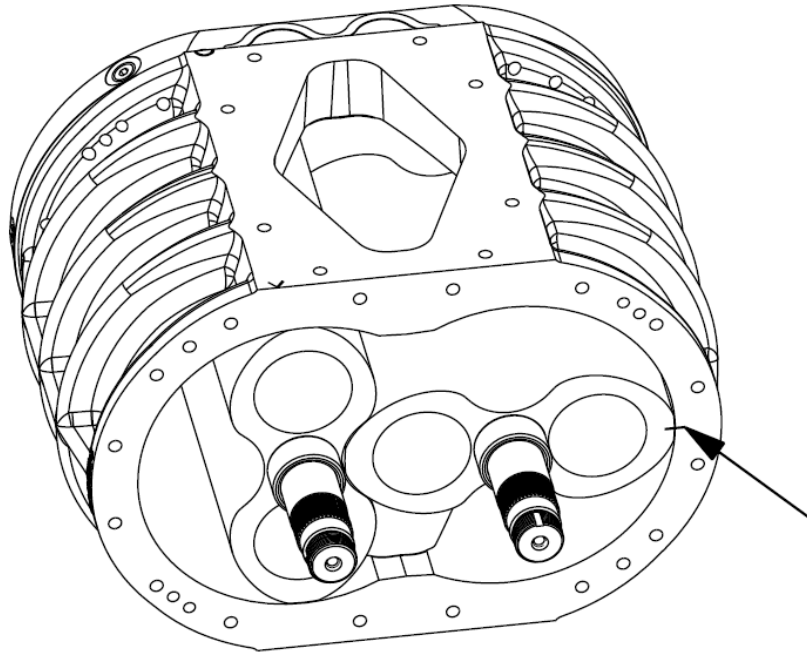
**Figure 7-23: Cap screw and dowel pin removal**

18. Remove the idle end headplate. Clean and remove any precision papers from the surface of the casing and headplate.



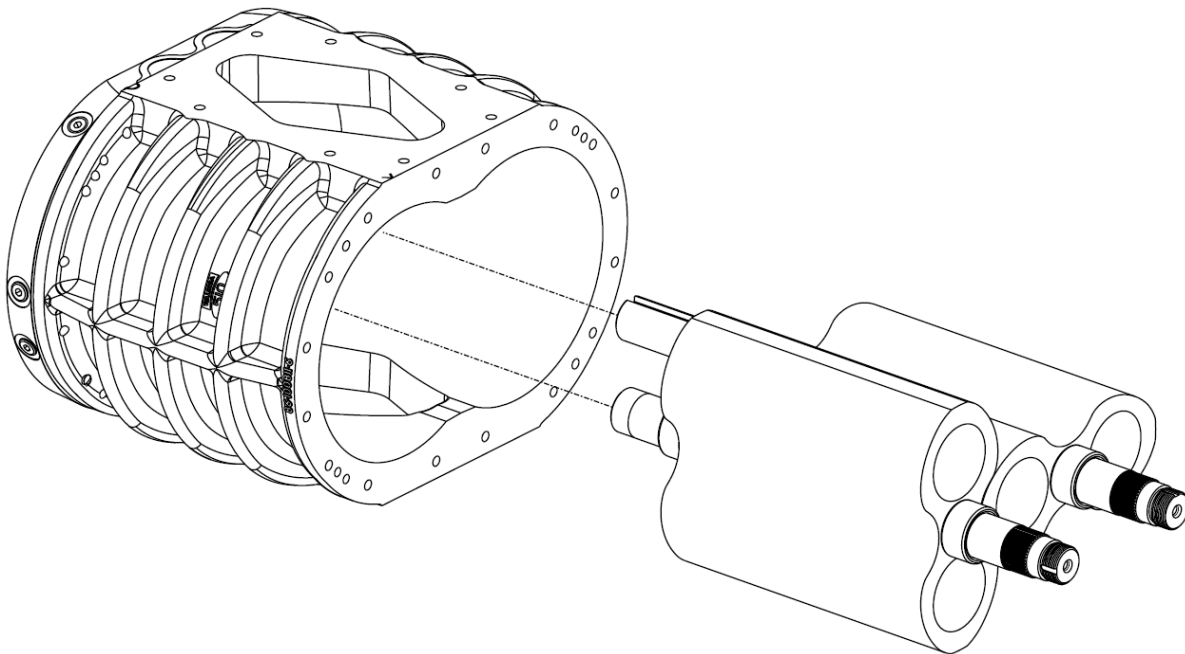
**Figure 7-24: Idle end headplate removal**

19. Mark the position of the driving impeller in the casing at the idle end.



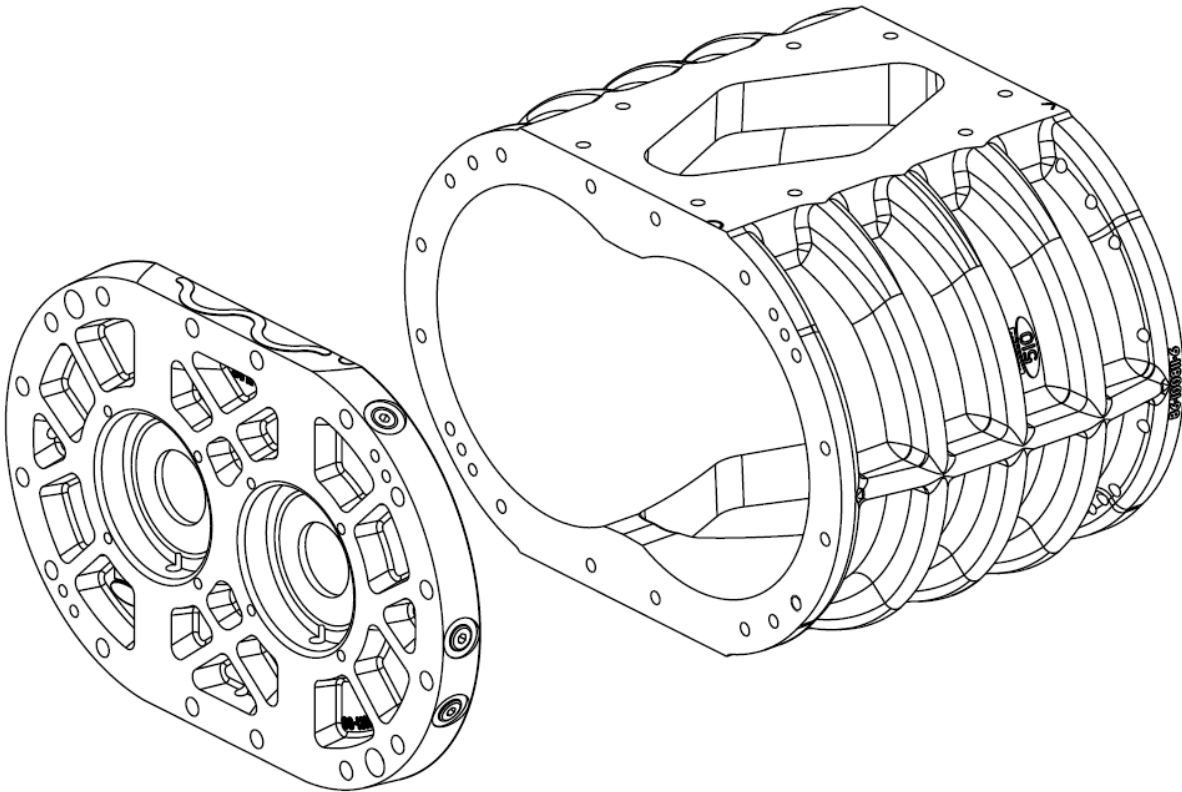
**Figure 7-25: Driving impeller position mark**

20. Carefully slide the impellers out of the drive end headplate and remove from the casing. Use care to not damage the impellers or the interior surfaces of the casing.



**Figure 7-26: Impeller removal**

21. Remove the drive end headplate. Clean and remove any precision papers from the surface of the casing and headplate.



**Figure 7-27: Drive end headplate removal**

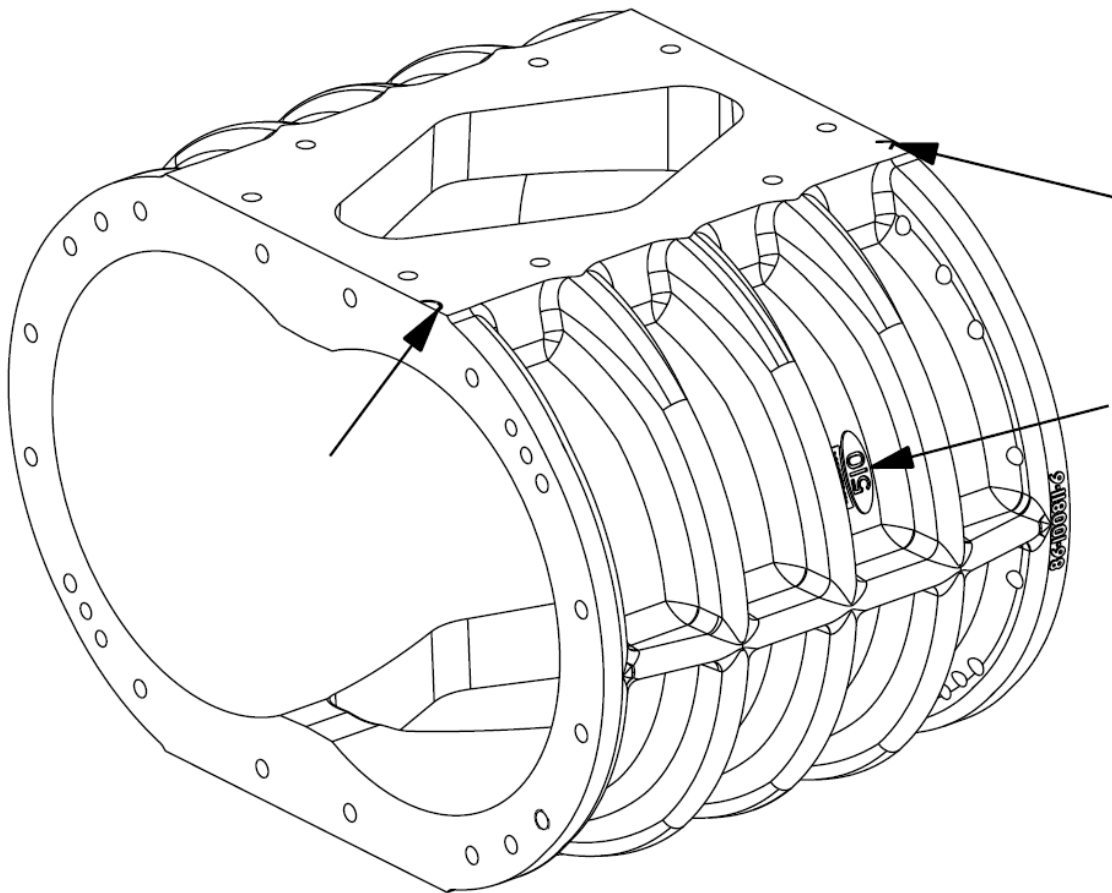
22. Clean all components and inspect for wear, damage, or heat discoloration. Repair or replace as required.

## Blower Assembly

After inspection, repair of components, replacement components or adjustment of the timing or clearances, the blower must be reassembled.

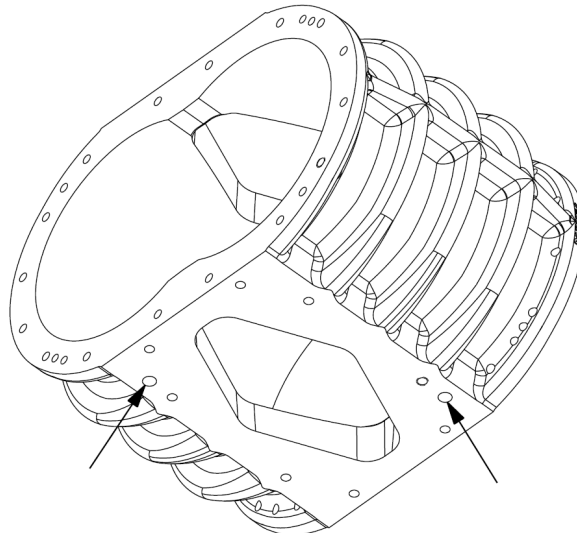
To assemble the blower, proceed as follows:

1. Clear the area of all bystanders, especially small children.
2. Refer to **Section 11: Parts List** for the available *Assembly Tools* to assist in the assembly of the blower.
3. Before assembly, ensure all components are free of dirt, dust and debris, use pressurized air to blow off or clean as necessary. Introduction of contaminants from dirty components can cause premature wear and failure of the blower.
4. Identify the headplate orientation marks created in **Step 16** and the driving impeller position mark created in **Step 19** of the *Blower Disassembly Procedure* and position the casing so the impeller mark (on the idle end) is facing away and the headplate marks are on the top. The model size should be on the right side of the casing.



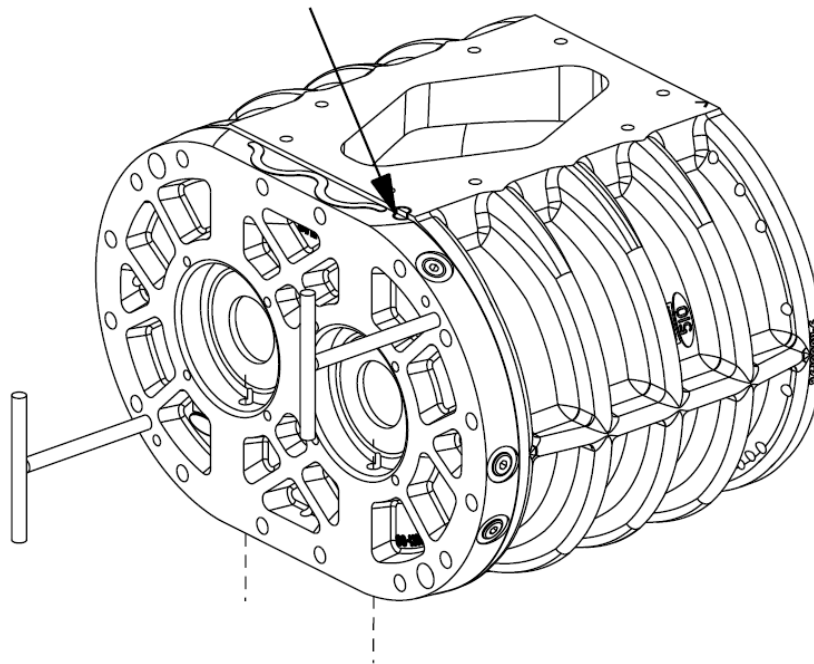
**Figure 7-28: Casing orientation**

5. Ensure the inlet of the casing is pointing upwards; the outlet surface will have two additional larger diameter holes compared to the inlet surface.



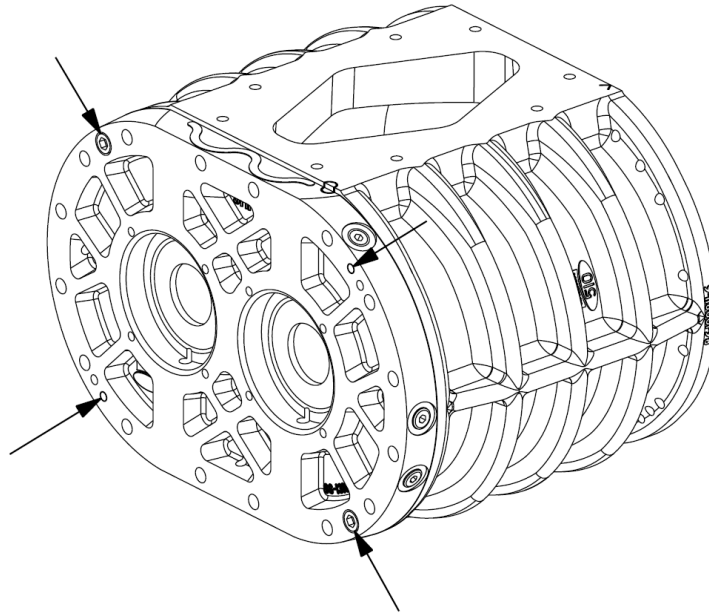
**Figure 7-29: Casing outlet surface**

6. Position the drive end headplate against the casing using the alignment tools as available. Ensure the position marks created in **Step 16** of the *Blower Disassembly Procedure* on the headplate and casing are aligned, the smooth surface is towards the casing, and the vent holes in the headplate are pointing downwards.



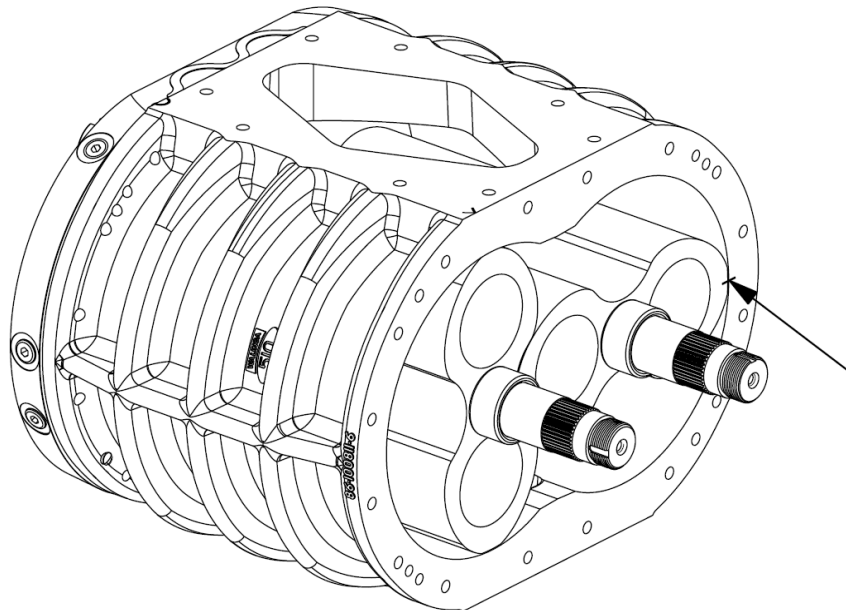
**Figure 7-30: Drive end headplate positioning**

7. Secure the headplate in place by installing the cap screws and dowel pins. Do not tighten completely.



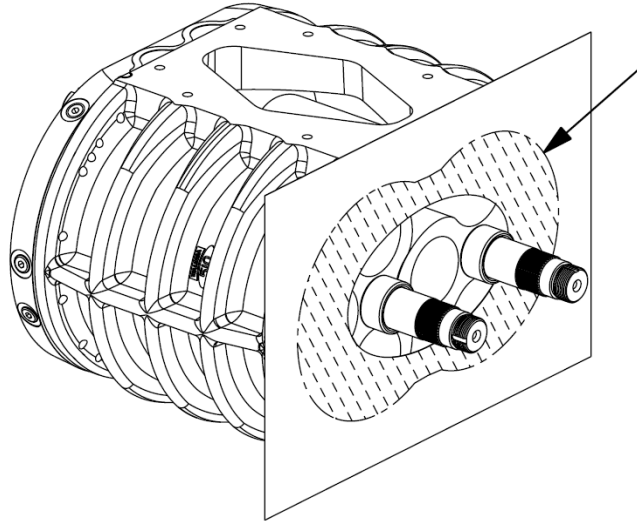
**Figure 7-31: Headplate securement**

8. Rotate the casing to access the idle end.
9. With reference to the driving impeller position mark, install the driving and driven impellers into the drive end headplate and casing.



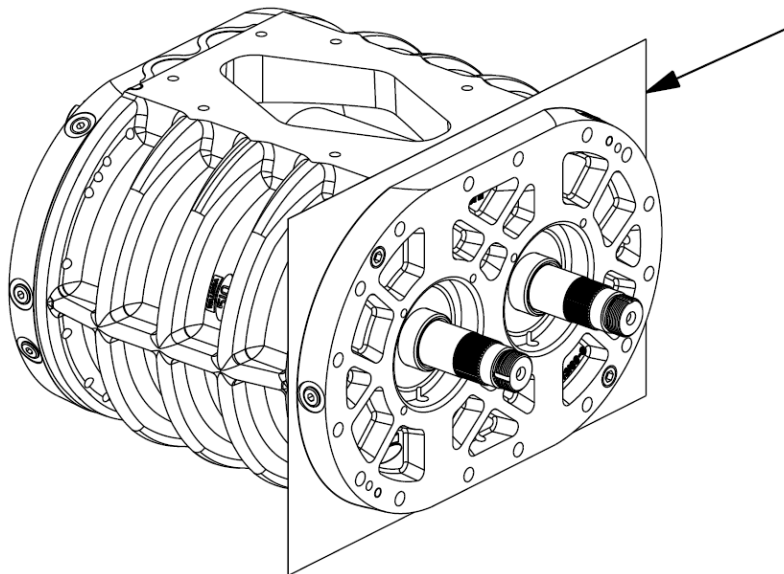
**Figure 7-32: Impeller installation**

10. Check the end clearances with reference to the section *Timing and Clearance Adjustments*.
11. Apply a small amount of blower oil to the idle end surface of the casing and position the precision paper onto the surface if necessary to achieve required end clearances. Trim the center of the precision paper to match the inner profile of the casing.



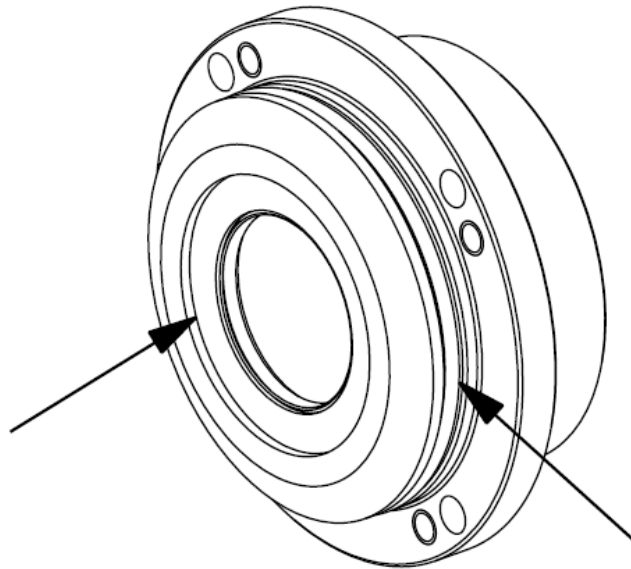
**Figure 7-33: Precision paper installation**

12. Repeat **Step 6** through **Step 7** to install the idle end headplate.
13. Trim any excess precision paper extending past the out profile of the headplate and casing.



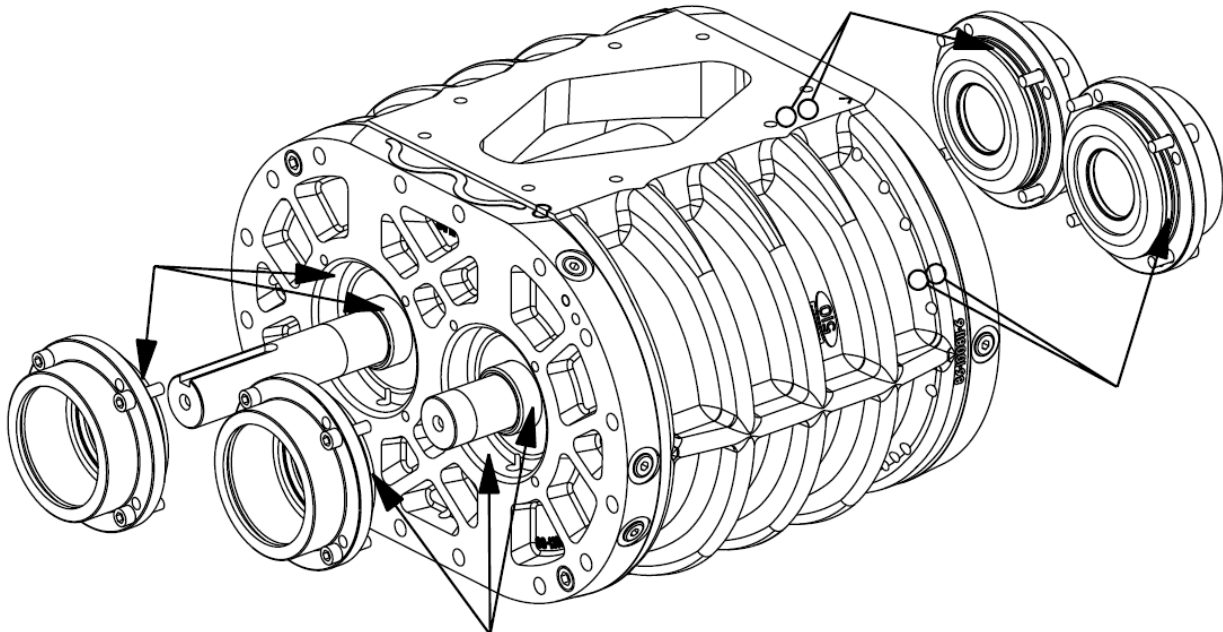
**Figure 7-34: Precision paper trimming**

14. Install new shaft seals in all bearing cartridges, ensuring the seals are fully seated. Apply Fluid Film lubricant and install new O-rings on all bearing cartridges.



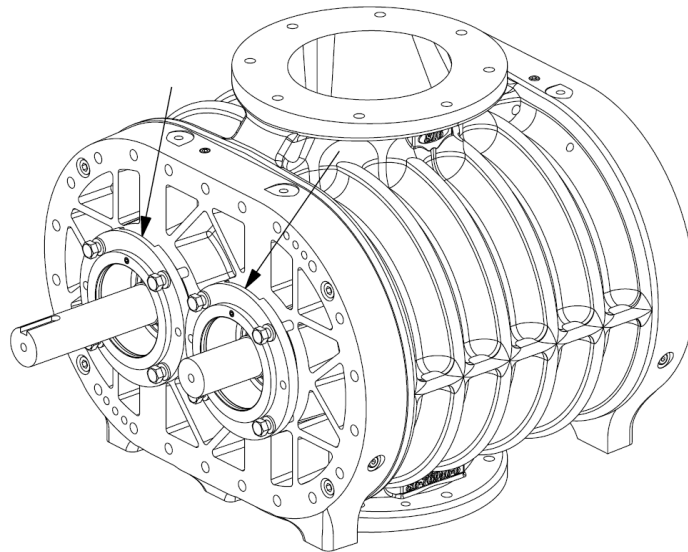
**Figure 7-35: Bearing cartridge shaft seal and O-ring**

15. Lubricate all cartridge pockets in the headplates, shaft sleeves of the impellers and bearing cartridges with Walinga Super Duty Blower Oil.



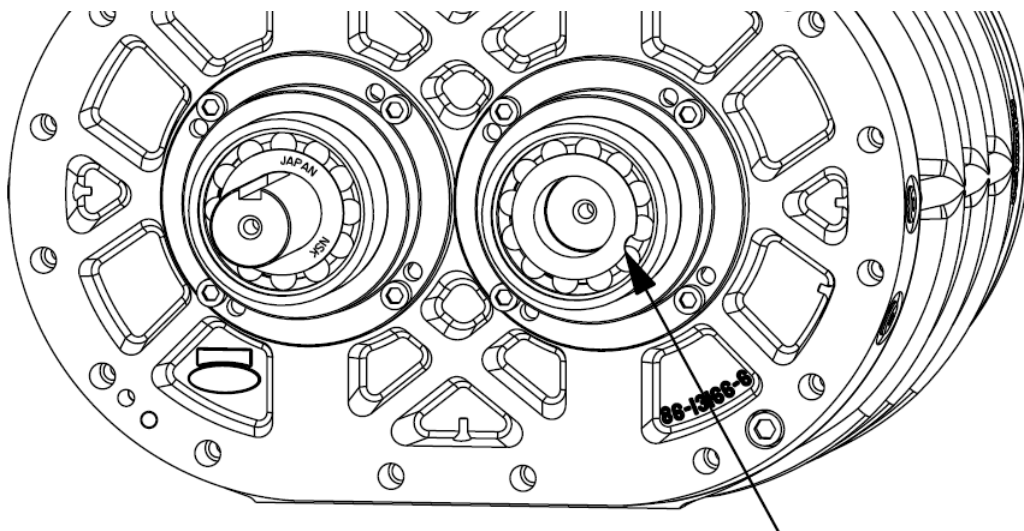
**Figure 7-36: Lubrication for bearing cartridge installation**

- Align the drive end bearing cartridges with the drive end headplate cartridge pockets, ensuring the oil groove, if equipped, is on the top. Start the fasteners into the threads.



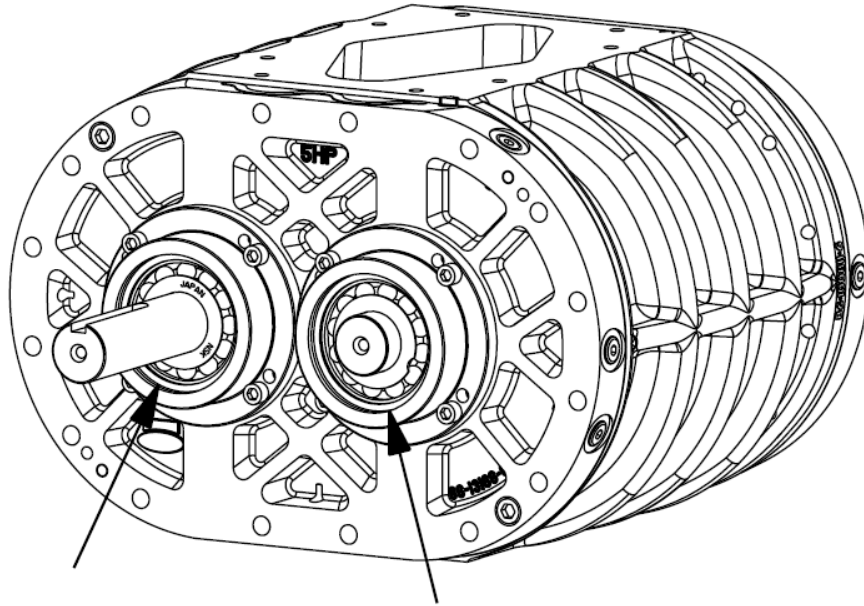
**Figure 7-37: Drive end cartridge installation**

- Carefully drive the bearing cartridge assemblies into the headplate and ensure they are fully seated.
- Lubricate the inner surface of the bearing cartridge and impeller shaft with Walinga Super Duty Blower Oil.
- Orient a new bearing on the driving impeller shaft such that the oil filling slot is facing inwards towards the casing. Orient a new bearing on the driven impeller shaft such that the oil filling slot is facing outwards.



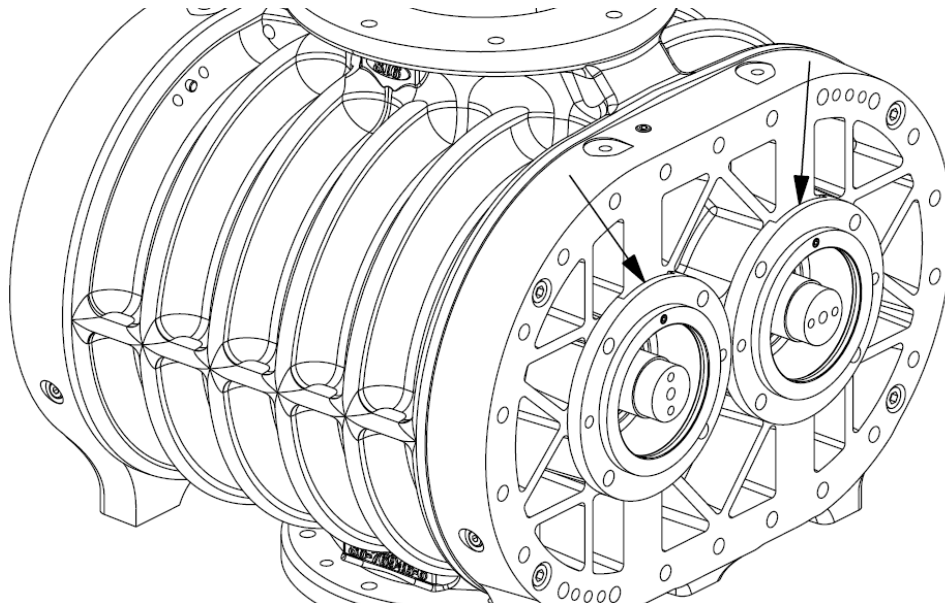
**Figure 7-38: Drive end bearing orientation**

20. Use a bearing driver to install the bearings into the cartridges, ensuring they are fully seated. **NOTE:** the long driver must be used to accommodate the input shaft of the driving impeller.



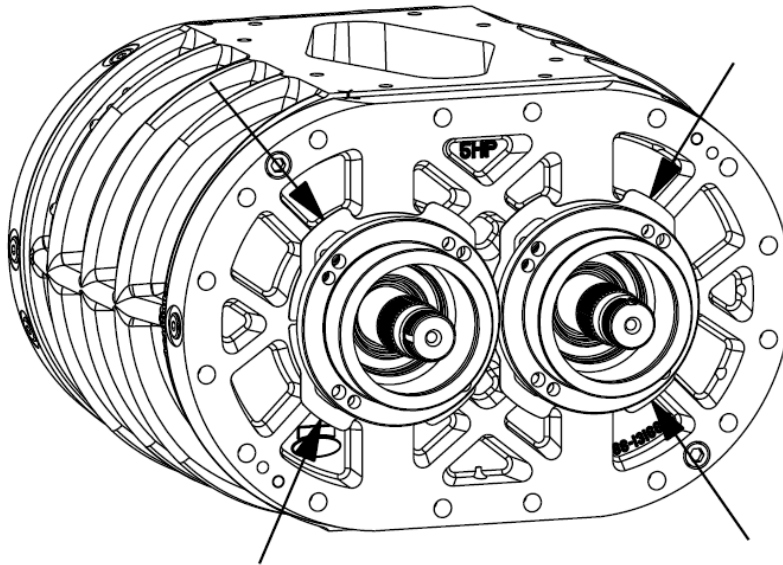
**Figure 7-39: Installation of bearings**

21. Tighten the bearing cartridge fasteners to the required torque.  
 22. Align the idle end bearing cartridges with the idle end headplate cartridge pockets, ensuring the oil groove, if equipped, is on the top.



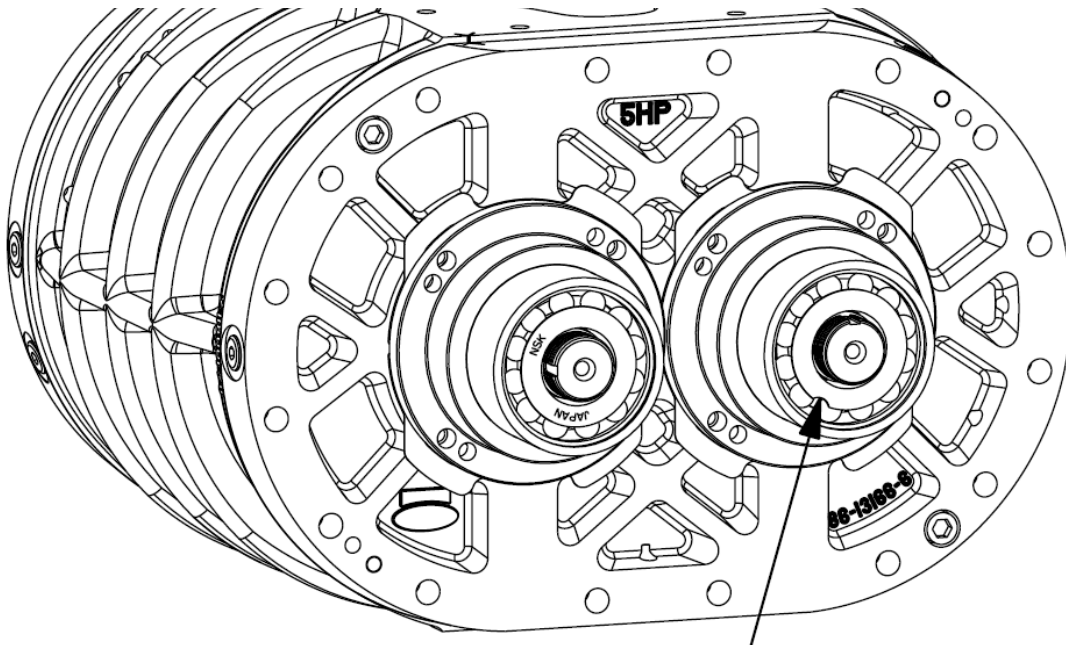
**Figure 7-40: Idle end cartridge installation**

23. Install any original shims between each idle end cartridge and headplate. Ensure the same thickness of shim is used for each cartridge and each side.



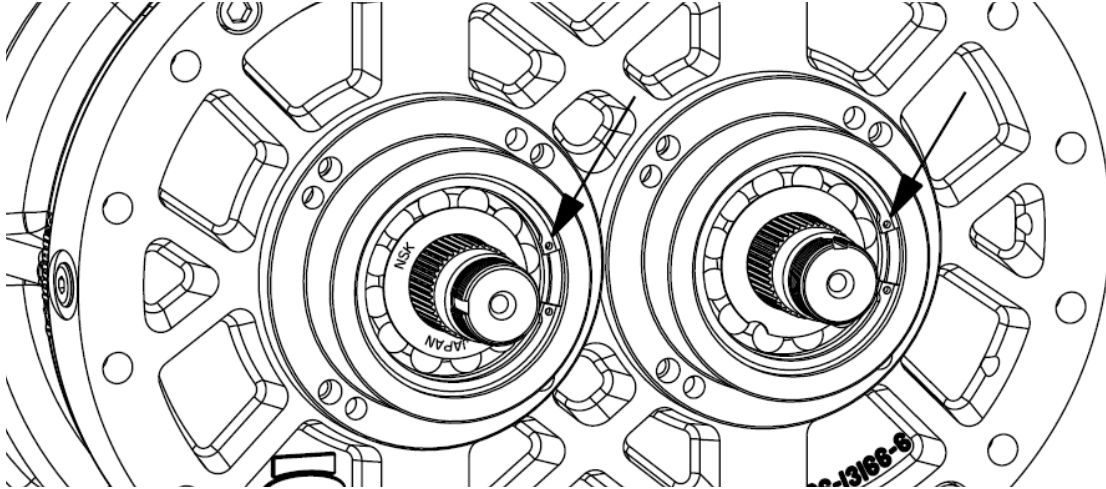
**Figure 7-41: Cartridge shim installation**

24. Repeat **Step 17** through **Step 18**.
25. Orient a new bearing on the driving impeller shaft such that the oil filling slot is facing outwards. Orient a new bearing on the driven impeller shaft such that the oil filling slot is facing inwards.



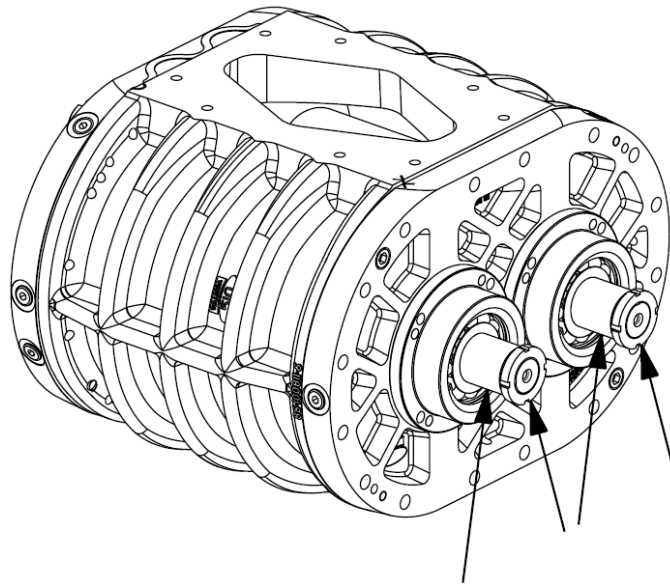
**Figure 7-42: Idle end bearing orientation**

26. Use a bearing driver to install the bearings into the cartridges, ensuring they are fully seated.
27. Install the retaining rings into the idle end bearing cartridges. Ensure the bevelled surface is facing outwards.



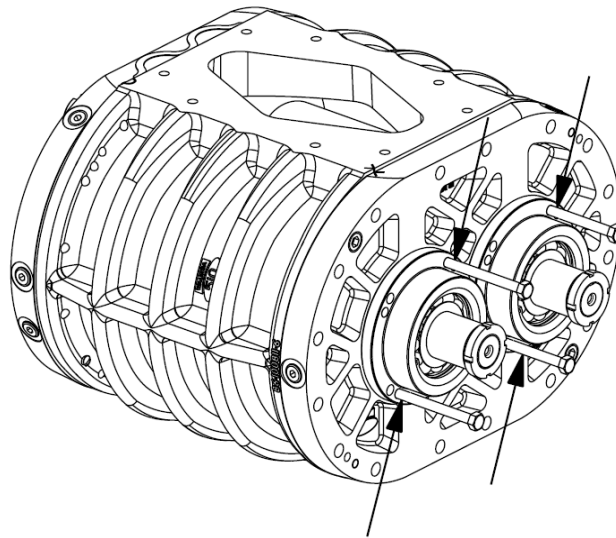
**Figure 7-43: Bearing retaining ring installation**

28. For **506**, **510** and **614** models only:
  - a. Using two pieces of 1-3/8" OD (34.9 mm OD) pipe cut at 1-1/2" (38.1 mm) in length, position the pipe over the idle end of the impeller shafts and secure in place with the locknut. The pipe is used for assembly only to keep the bearing positioned tightly to the shaft.



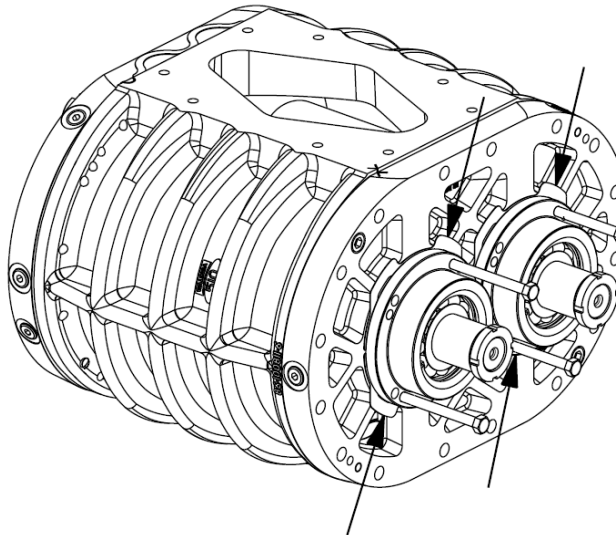
**Figure 7-44: Bearing securement pipe installation**

29. Install two long bolts in the top left and bottom right threaded holes of each idle end cartridge, do not tighten.



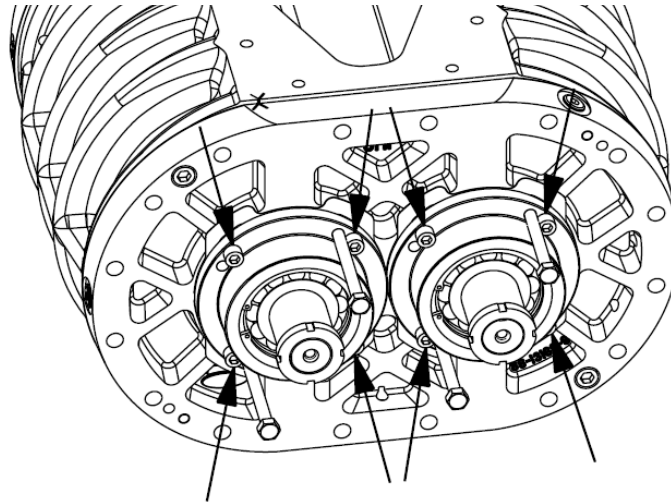
**Figure 7-45: Long bolt installation**

30. Check and adjust the tip clearances between the impellers and the casing with reference to the section *Timing and Clearance Adjustments*.
31. Tighten the long bolts in the idle end cartridges to slightly separate the cartridges from the headplate.
32. Slide a shim, if not already installed with original shims, less than 0.015" (0.38 mm) thick, between each idle end cartridge and headplate. Ensure the same thickness of shim is used for each cartridge and each side.



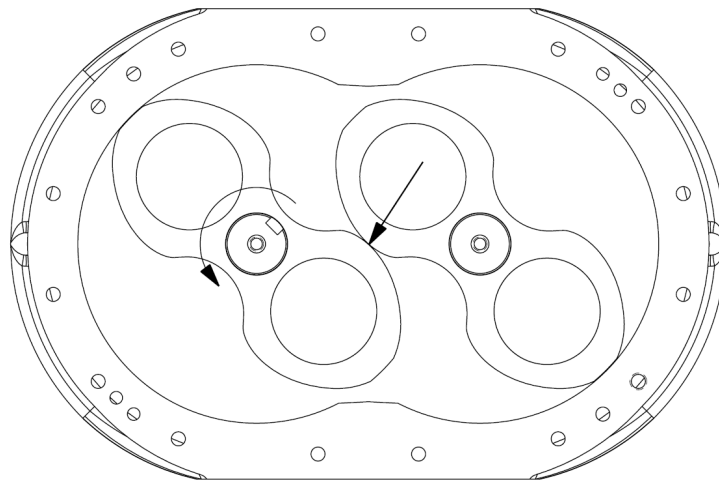
**Figure 7-46: Cartridge shim installation**

33. Loosen the long bolts in the cartridges and install fasteners to tighten the cartridges to the headplate.



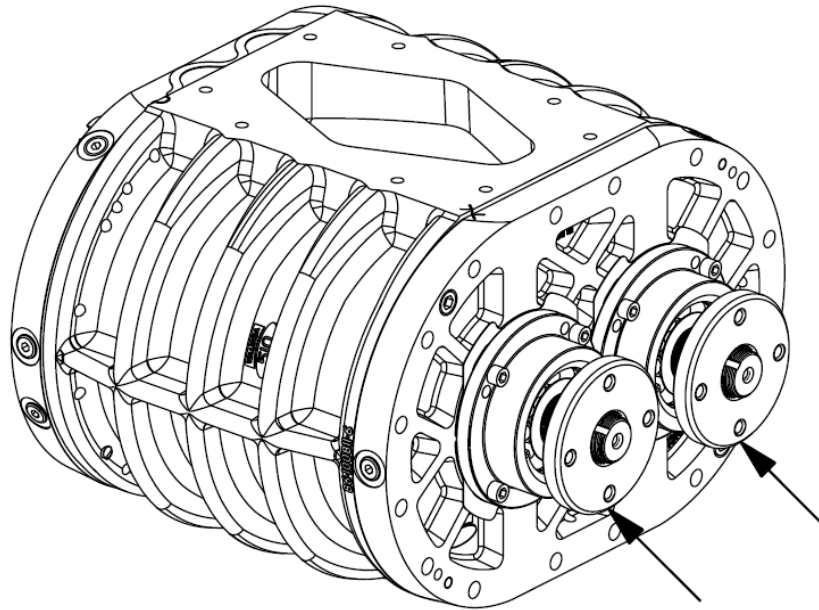
**Figure 7-47: Idle end cartridge fastener installation**

34. Check and adjust the end clearance between the impellers and headplates with reference to the section *Timing and Clearance Adjustments*.
35. Once proper end clearances have been achieved, remove the long bolts from the cartridges and install new locking fasteners to secure the cartridge to the headplate.
36. For **506**, **510** and **614** models only:
- Remove the lock nut and section of pipe installed in **Step 17a**.
  - Position the impellers in a 45° position, such that the leading edge timing clearance can be measured, and insert the required feeler gauge with reference to **Table 7-4**, ensuring the impeller positioning is correct.



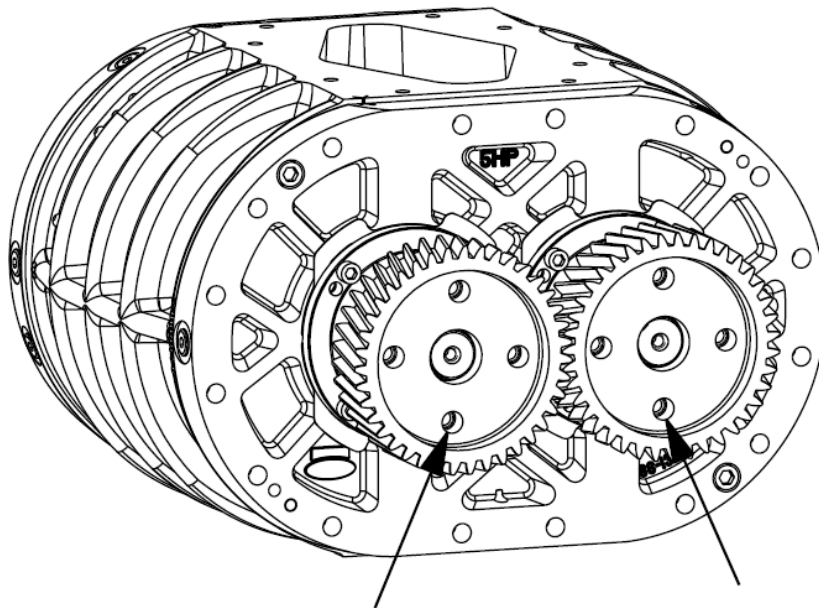
**Figure 7-48: Impeller positioning (seen from drive end of LHD blower)**

- c. Position the timing hubs loosely on the impeller shafts so the hub splines just start on the shaft splines.



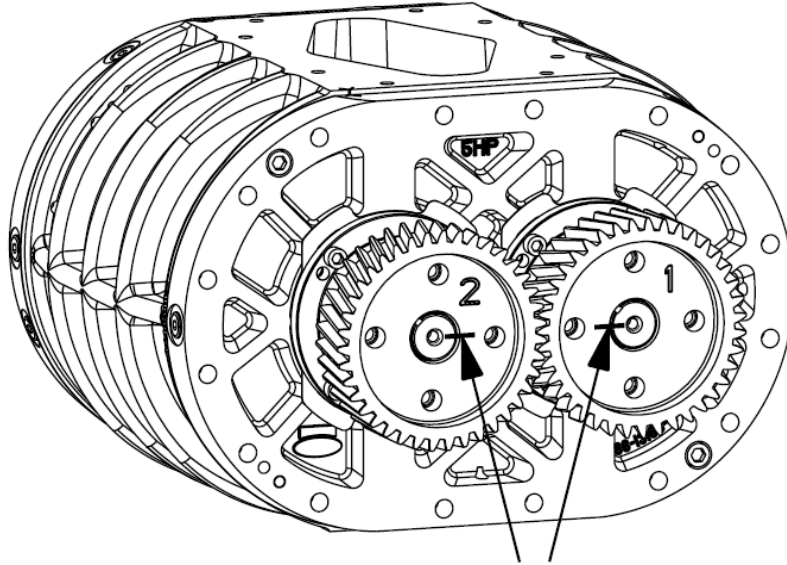
**Figure 7-49: Timing hub positioning**

- d. Position the timing gears on the timing hubs and align the fastener holes. The orientation groove on the gears must be towards the timing hub; the visible face of the timing gears must be smooth.



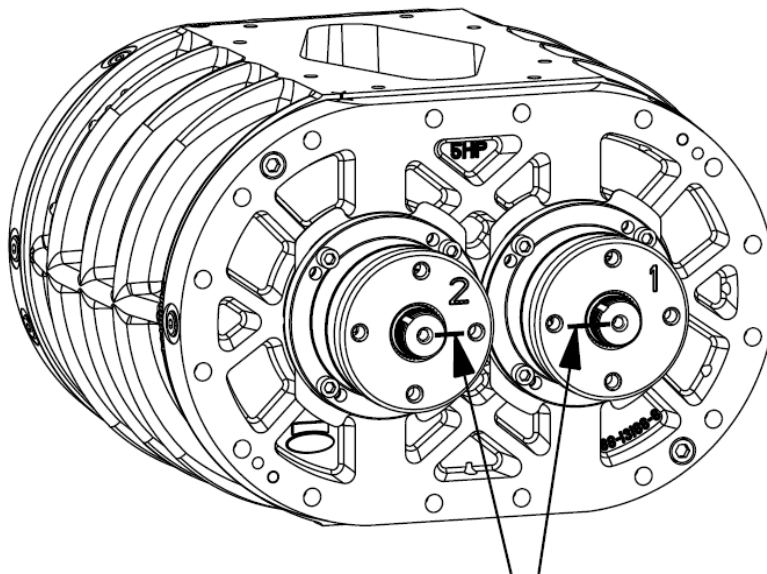
**Figure 7-50: Timing gear positioning**

- e. Draw a line across both timing gears and shaft ends to use as an alignment reference and label the timing gear on the driving impeller shaft with **1** and label the timing gear on the driven impeller shaft with **2**. Remove the gears from the shafts.



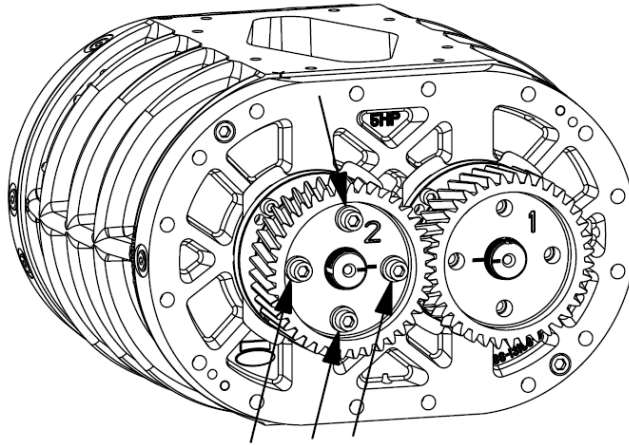
**Figure 7-51: Position marking of timing gears and shafts**

- f. Draw a line on each timing hub that is aligned with the mark made in **Step 25e** and label the timing hub on the driving impeller shaft with **1** and label the timing hub on the driven impeller shaft with **2**, matching that of the timing gears.



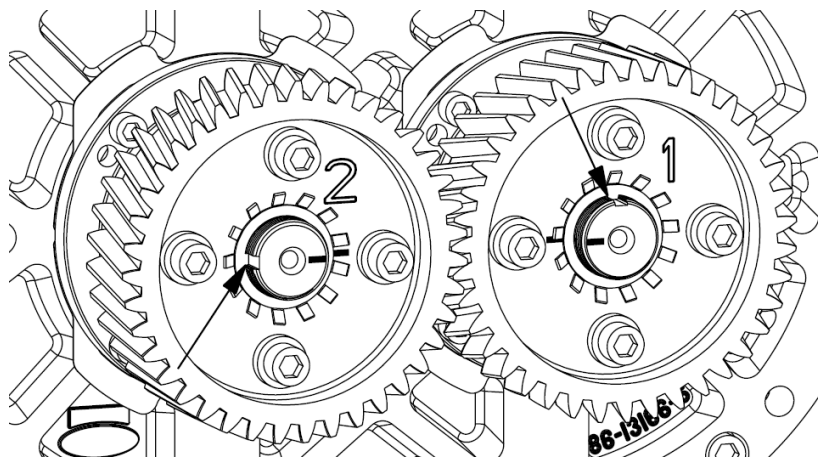
**Figure 7-52: Timing hub position marking**

- g. Heat the timing hubs and drive the hubs onto the splined shaft, ensuring the previously drawn lines are aligned.
- h. Position the timing gears on the hubs, aligning the previously marked lines.
- i. Install and tighten the fasteners of the driven impeller timing gear. Always install new timing washers.



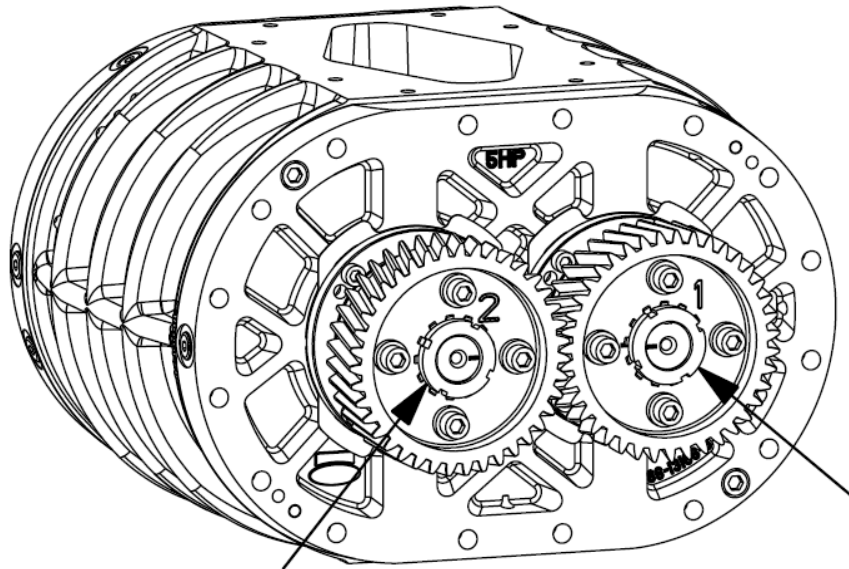
**Figure 7-53: Driven impeller timing gear fastener installation**

- j. Properly set the timing clearance between the impellers with reference to the section *Timing and Clearance Adjustments*.
- k. Once the correct timing clearances have been achieved for both the leading and trailing edge, install and tighten the fasteners on the driving impeller timing gear.
- l. Secure the timing gear assemblies in place by installing the shaft lock washers and lock nuts as follows:
  - i. Slide the lock washers onto the impellers shafts, ensuring the inner tab of the lock washer is aligned with the notch in the impeller shaft.



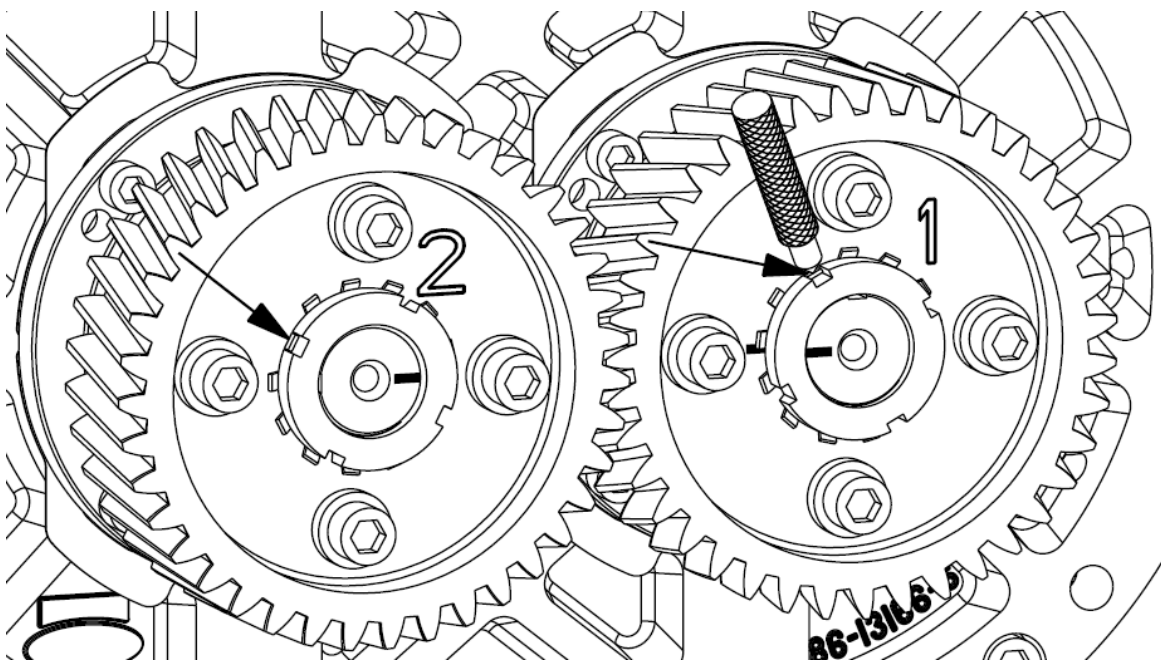
**Figure 7-54: Lock washer tab and shaft notch alignment**

- ii. Install and tighten the lock nuts to the required torque.



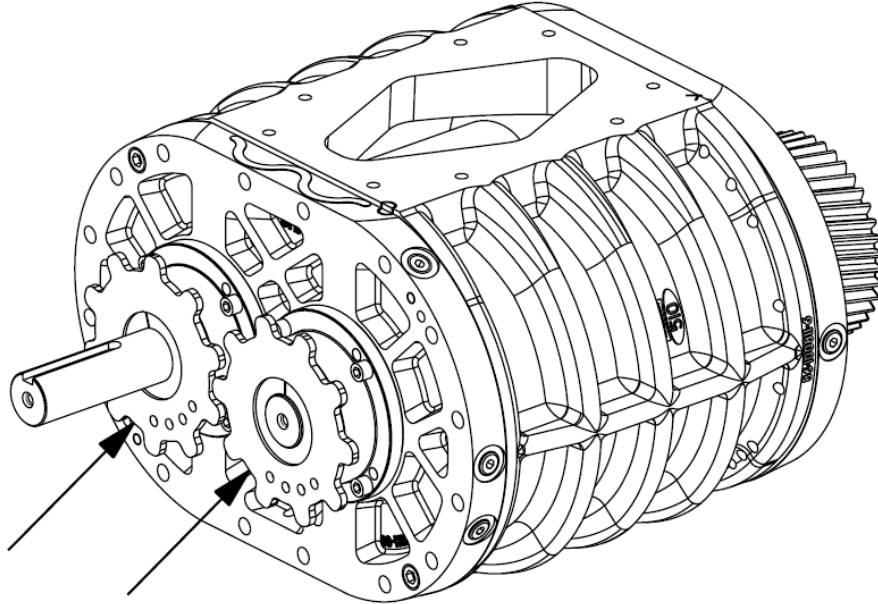
**Figure 7-55: Lock nut installation**

- iii. Identify the lock washer tab that is aligned with a notch in the lock nut. Use a punch to slightly bend the tab into the notch to fix the lock washers and lock nuts to the shafts. Do not bend the tab to the bottom of the notch as this will prevent easy disassembly.



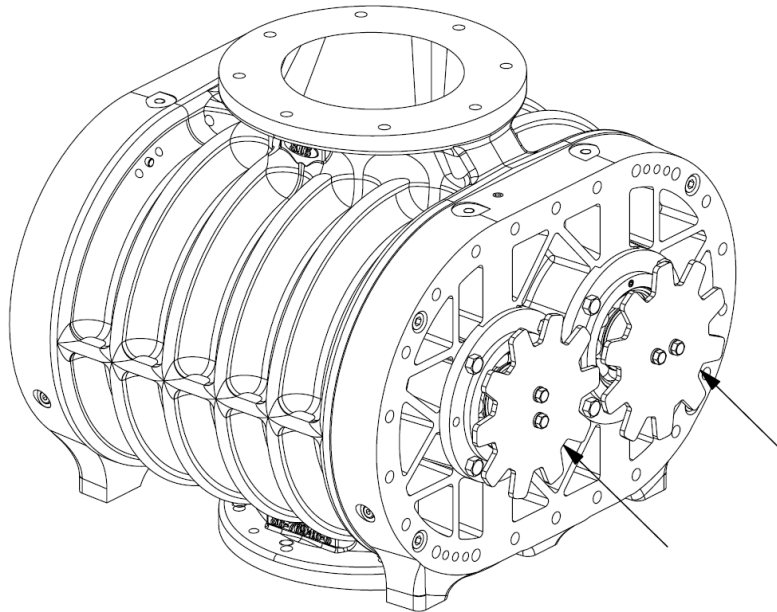
**Figure 7-56: Lock nut and washer position securement**

- m. Ensure all timing gear fasteners are tightened to the required torque.
- n. At the drive end, install an oil slinger on each shaft and secure in place by tightening the set screw on the impeller shaft.



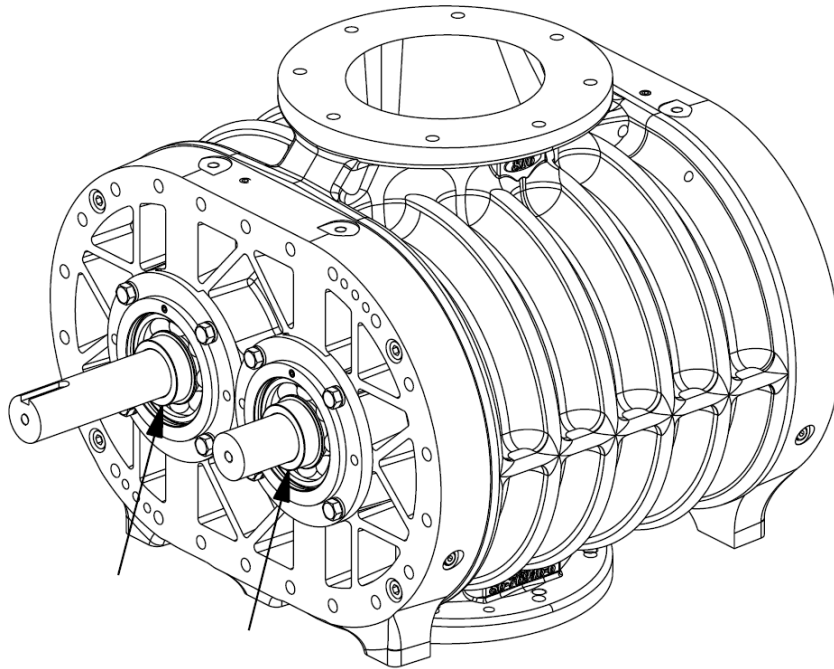
**Figure 7-57: Oil slinger installation**

- 37. For **816** and **1020** models only:
  - a. Install and secure an oil slinger on the idle end of each impeller shaft.



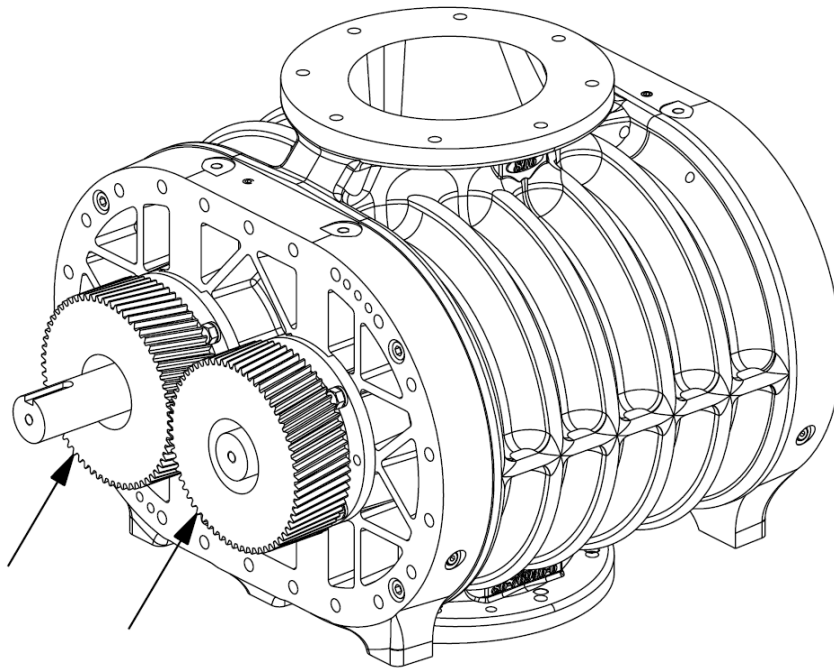
**Figure 7-58: Oil slinger installation**

- b. Install a gear spacer onto the drive end of each impeller shaft.



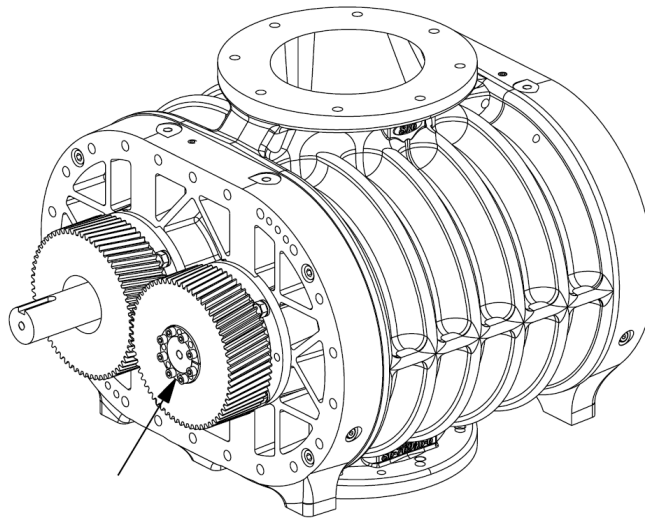
**Figure 7-59: Gear spacer installation**

- c. Install the timing gears onto each impeller shaft.



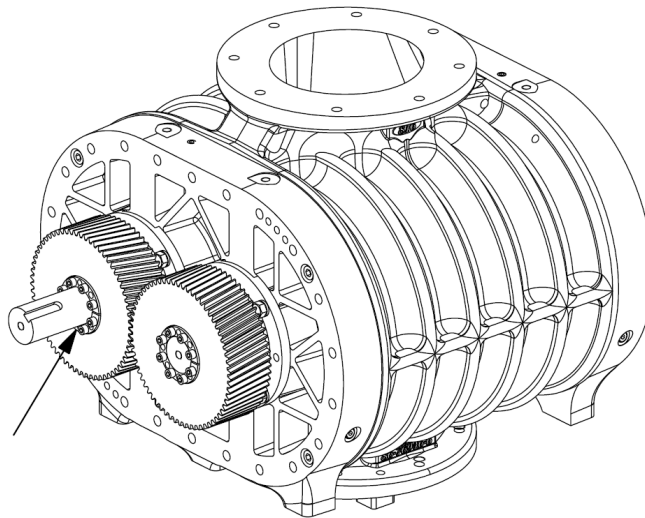
**Figure 7-60: Timing gear installation**

- d. Insert the loosely assembled locking bushing into the timing gear of the driven impeller. Ensure the gears are seated against the gear spacers.



**Figure 7-61: Driven impeller locking bushing installation**

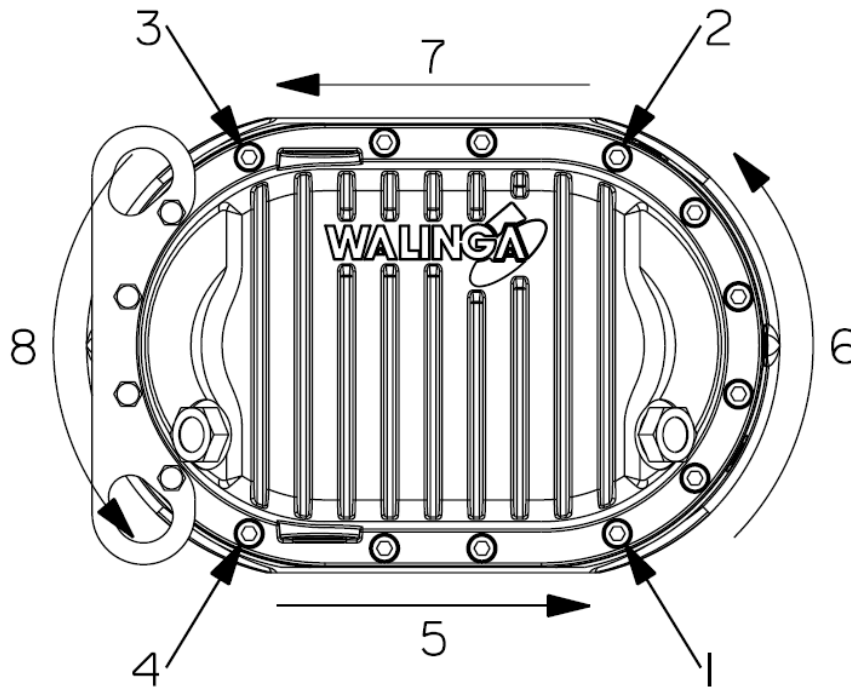
- e. In a clockwise pattern, begin to tighten the locking screws of the driven impeller bushing, turning each screw only a quarter turn (90°) at a time and repeating the pattern until a torque of 20 lb-ft (27 Nm) is reached.
- f. Insert the loosely assembled locking bushing into the timing gear of the driving impeller. Ensure the gear is seated against the gear spacer.



**Figure 7-62: Driving impeller locking bushing installation**

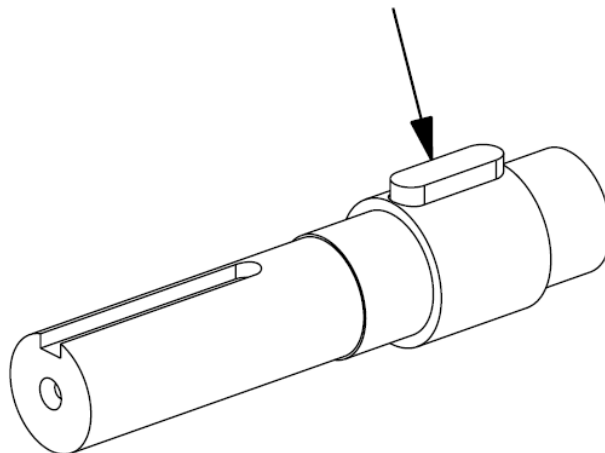
- g. Properly set the timing clearance between the impellers with reference to the section *Timing and Clearance Adjustments*.

38. Ensure all fasteners are tightened to the required torque.
39. Install a new gasket, the idle end cover and lifting hook onto the idle end of the casing and secure in place with the required fasteners. Tighten the first four fasteners in the order specified in the figure below and tighten all other fasteners in a circular direction.



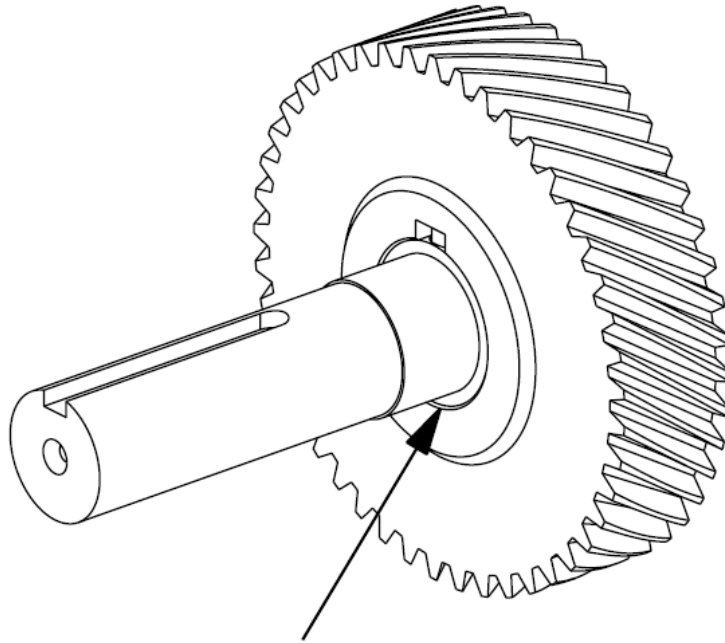
**Figure 7-63: Idle end cover fastener installation order**

40. For **Gear Head** models only:
  - a. Lubricate the input shaft, gears and bearings.
  - b. Install a new key into the keyway of the input shaft.



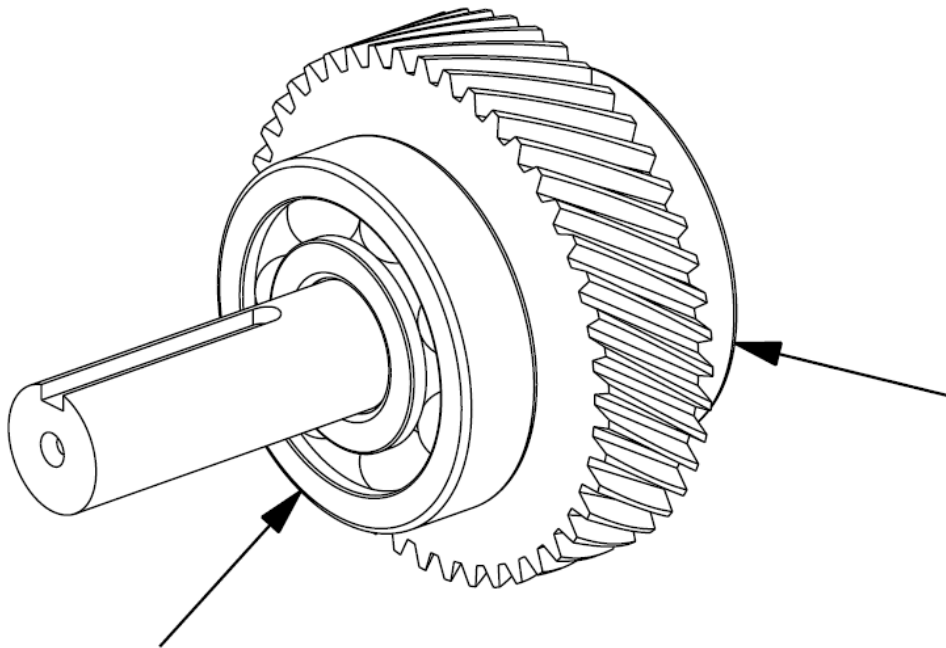
**Figure 7-64: Input shaft key installation**

- c. Press the gear onto the input shaft until it is centered on the shaft step.



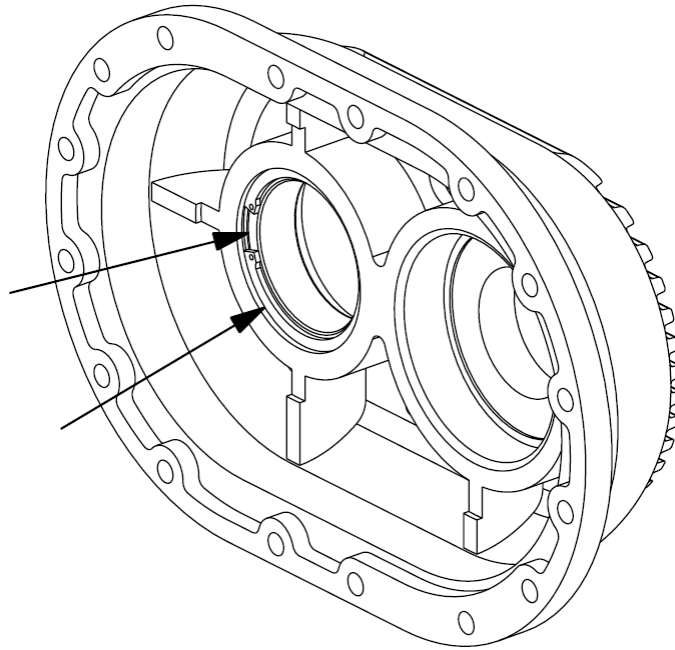
**Figure 7-65: Input shaft gear installation**

- d. Using a mating sleeve over the outer diameter of the input shaft, carefully drive a new bearing into position on both ends of the input shaft.



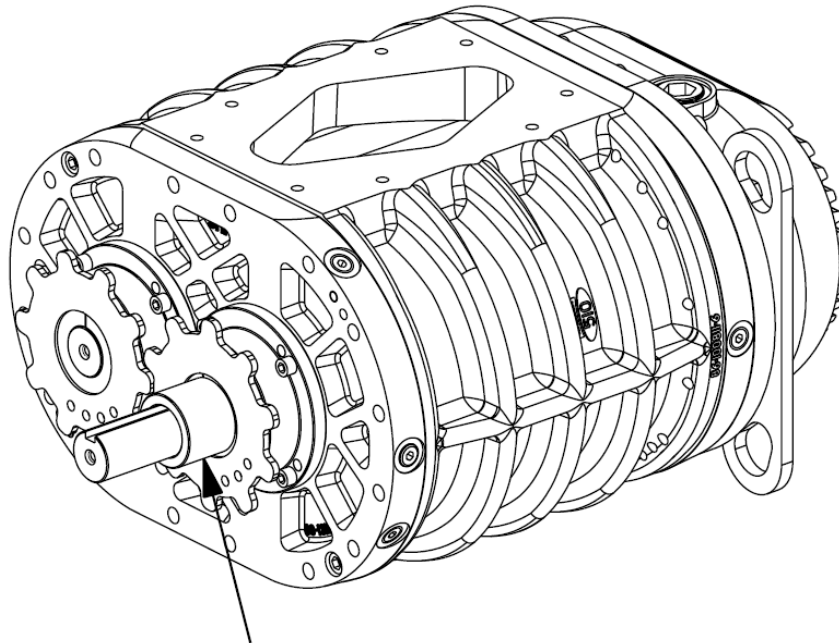
**Figure 7-66: Input shaft bearing installation**

- e. Drive the outer race of the pinion gear bearing into the drive end cover and secure in place by installing the retaining ring.



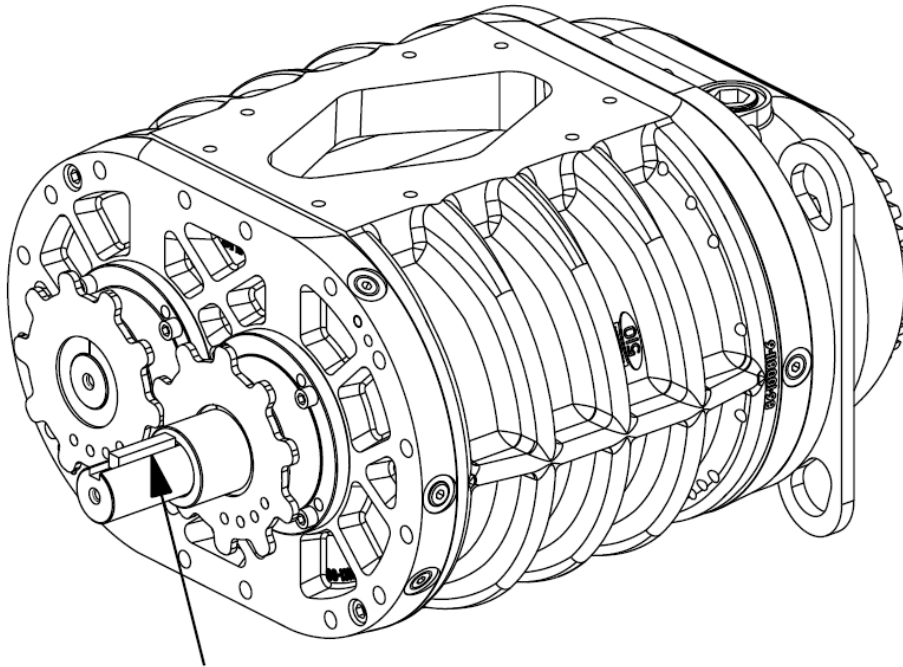
**Figure 7-67: Bearing outer race and retaining ring installation**

- f. Install the gear spacer onto the impeller shaft.



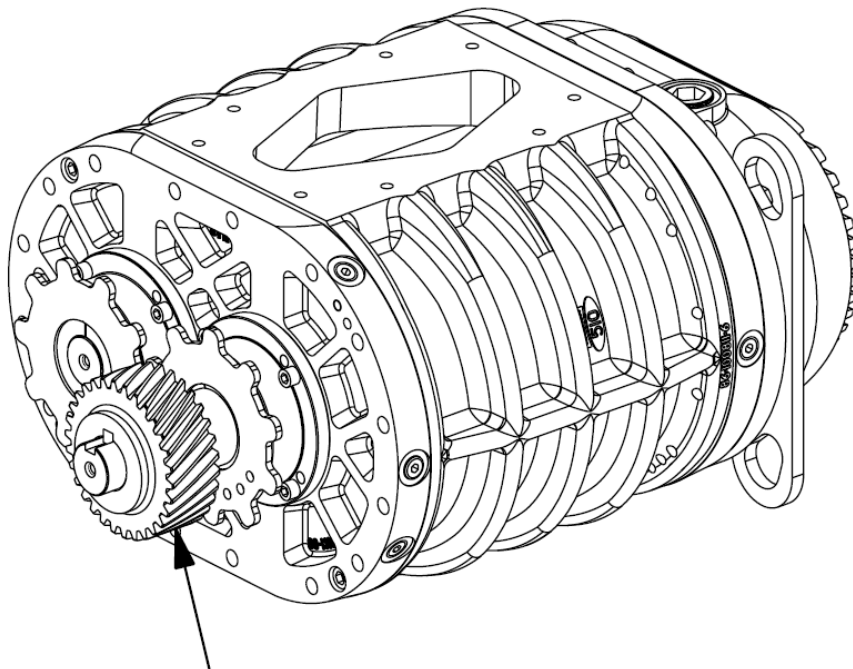
**Figure 7-68: Gear spacer installation**

- g. Install a new key into the impeller shaft keyway.



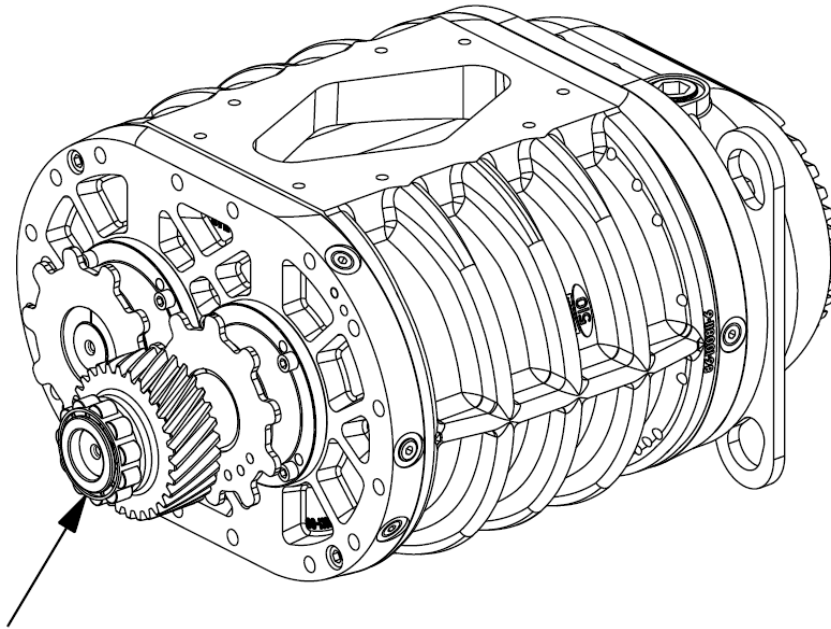
**Figure 7-69: Impeller shaft key installation**

- h. Press the pinion gear onto the impeller shaft until it is seated against the spacer.



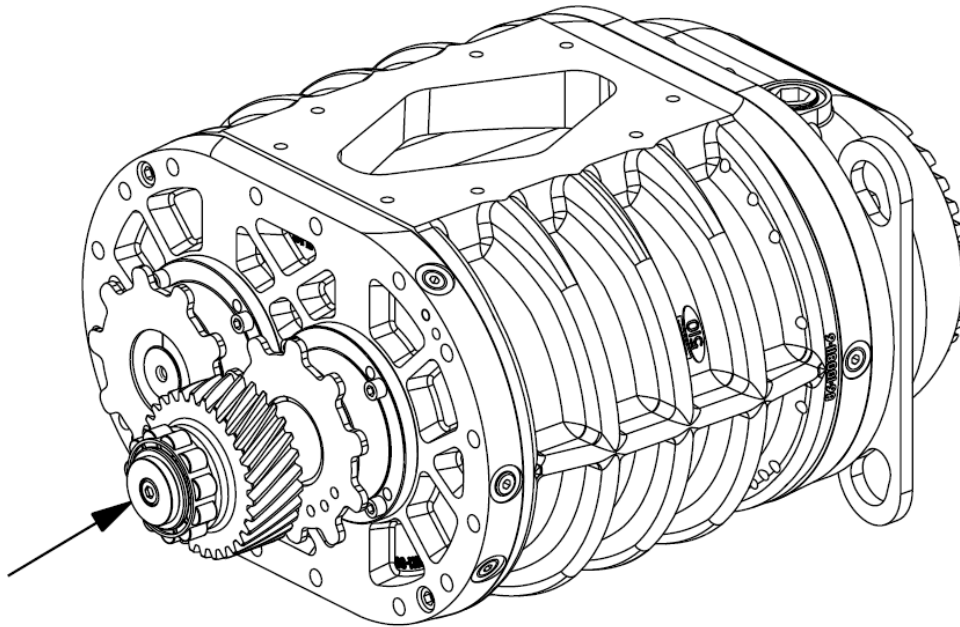
**Figure 7-70: Pinion gear installation**

- i. Drive the inner race of the pinion gear bearing onto the impeller shaft until it is seated against the pinion gear.



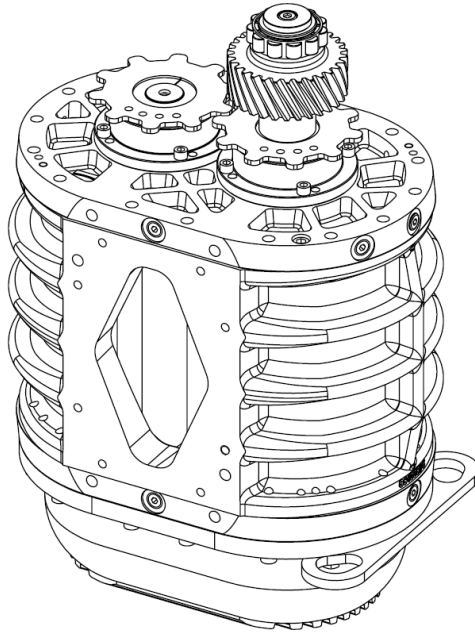
**Figure 7-71: Bearing inner race installation**

- j. Apply Loctite to the cap screw and install and secure the retaining plate onto the impeller shaft.



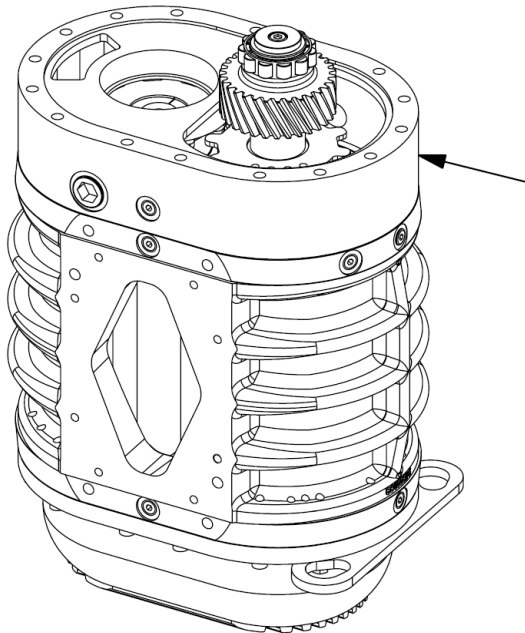
**Figure 7-72: Retaining plate installation**

- k. To assist with installation, reorient the blower into a vertical position such that the drive end is pointed upwards.



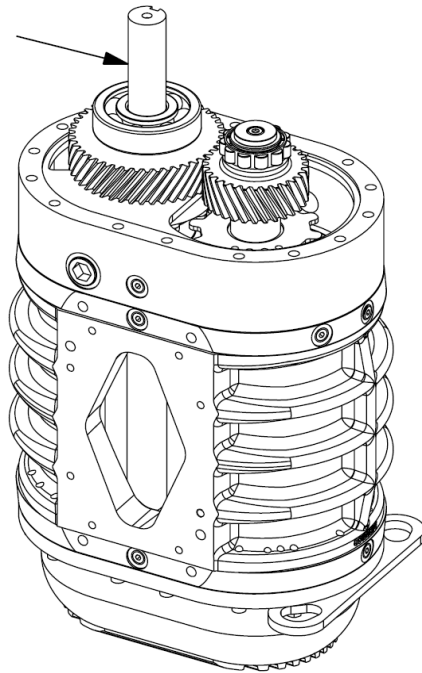
**Figure 7-73: Vertical positioning of blower**

- l. Position a gasket and the adapter onto the drive end headplate. The larger opening of the adapter must be aligned with the longer impeller shaft.



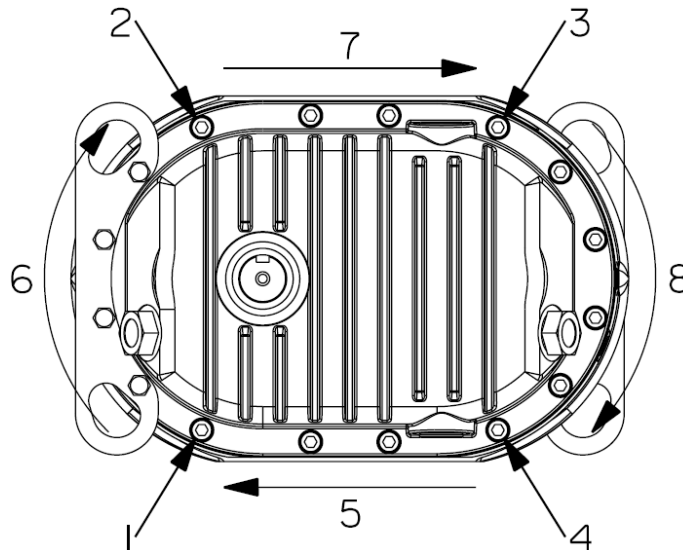
**Figure 7-74: Gasket and headplate positioning**

- m. Install the input shaft assembly into the adapter, ensuring the gear teeth mesh properly with the installed pinion gear.



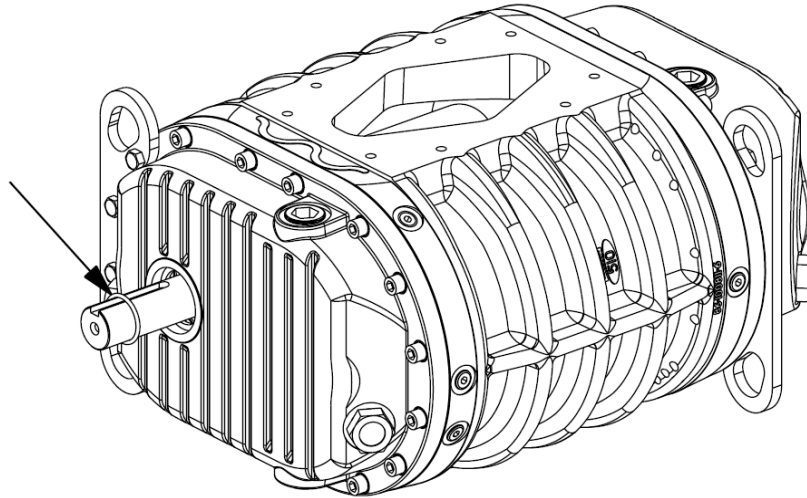
**Figure 7-75: Input shaft installation**

41. Install a gasket, the drive end cover and lifting hook, ensure the drive shaft seal hole is centered around the driving impeller shaft. Secure in place with the required fasteners. Tighten the first four fasteners in the order specified in the figure below and tighten all other fasteners in a clockwise direction.



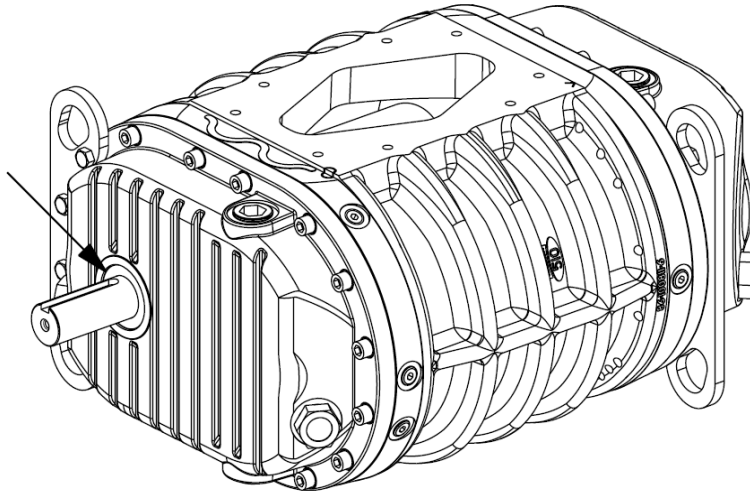
**Figure 7-76: Drive end cover installation**

42. Position a new O-ring, if originally equipped, on the input shaft of the driving impeller.



**Figure 7-77: Input shaft O-ring positioning**

43. Install a new shaft seal(s) into the cover around the driving impeller shaft, applying Loctite Red (609). Ensure the O-ring is flush against the inner surface of the seal.



**Figure 7-78: Shaft seal installation**

44. Recheck all clearances and ensure all fasteners are tightened to the required torque as specified in **Section 8: Specifications**.
45. Ensure all plugs are installed in the headplates and covers, the sight glasses are installed in the covers using Loctite Blue (242), the breathers are installed or connected to the headplate, and the headplate vents are clear.
46. Refer to the *Changing of Reservoir Oil* procedures and fill the drive end and idle end reservoirs with the required volume of oil.

## MAINTENANCE PROCEDURES

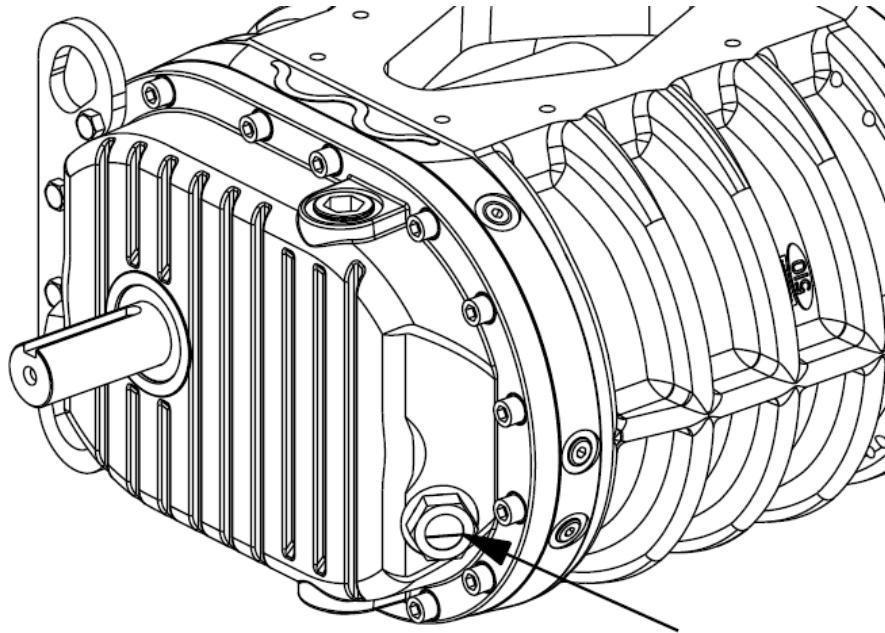
### Adjustment and Changing of Reservoir Oil

The gears and bearings that drive, time and support the impellers operate in a self-contained splash lubrication oil bath. For proper lubrication and operation, the oil level in both reservoirs must remain clean and at the required level. Low oil levels will cause overheating and premature wear due to insufficient lubrication. Excessive oil levels will also cause overheating as a result of oil churning and can lead to seal and breather leaks. During normal operation, condensation may form and collect in the oil reservoirs; changing the oil at the prescribed intervals removes this water and any other contaminants to prevent damage and wear to the gears and bearings. Never mix different types of oils; Walinga blowers are designed to function with the use of Walinga Super Duty Blower Oil (98-13813-6).

To maintain the correct oil levels of the reservoirs, proceed as follows:

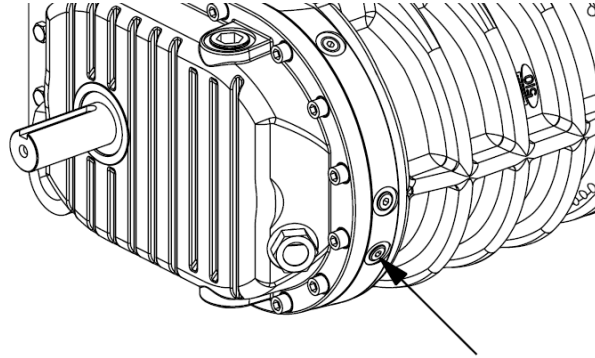
1. Clear the area of bystanders, especially small children.
2. Ensure all controls are in neutral, and the power source is stopped and locked-out.
3. Allow the blower to cool after operation. Contact with hot oil can cause severe injury.
4. Ensure the blower is level, reading and adjusting the oil of an unlevel blower can lead to improper lubrication levels.
5. Examine the oil level sight glass(es) at the drive end and idle end of the blower. The oil level must clearly appear slightly below the center of all sight glasses.

**NOTE:** The drive end and idle end reservoirs are independent. They must each be individually inspected and adjusted.



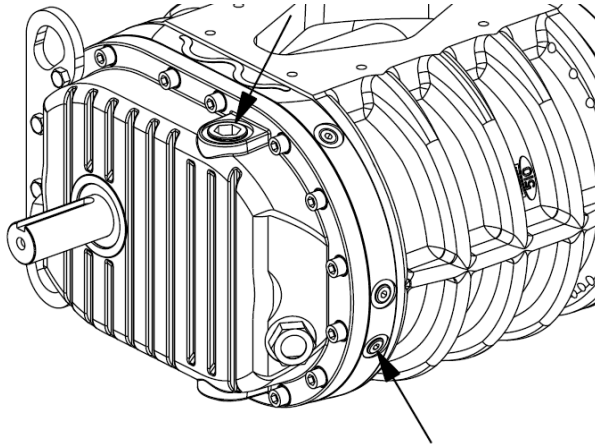
**Figure 7-79: Correct oil level in sight glass**

6. If the oil level of a reservoir is too high, proceed as follows:
  - a. Position a receptacle below the blower to catch the oil drainage.
  - b. Loosen and remove the oil level plug.



**Figure 7-80: Oil level plug (drive end)**

- c. Allow the oil to drain from the oil level hole.
  - d. Reinstall the oil level plug. Tighten to the required torque.
7. If the oil level of a reservoir is too low, proceed as follows:
  - a. Position a receptacle below the blower to catch the oil drainage.
  - b. Loosen and remove the oil level plug and oil fill plug.

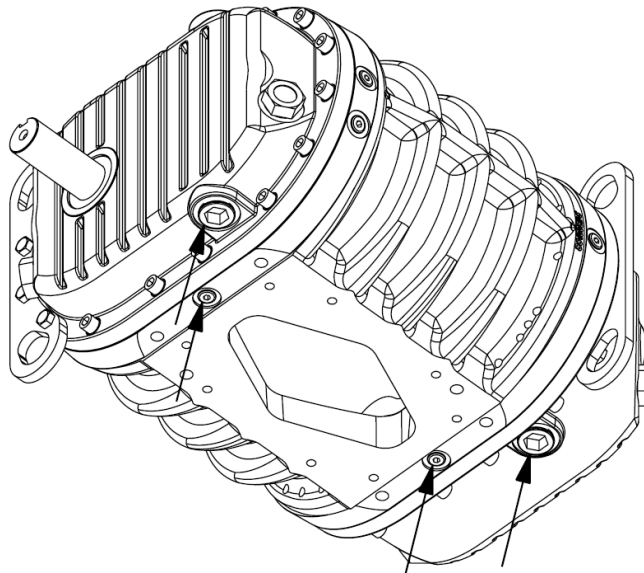


**Figure 7-81: Oil level and fill plugs (drive end)**

- c. Add Walinga Super Duty Blower Oil (98-13813-6) to the reservoir through the oil fill hole until oil is visible and drips from the oil level hole.
  - d. Reinstall the oil level plug and oil fill plug. Tighten to the required torque.
8. Reexamine the oil level sight glass(es) at the drive and idle end of the blower. Repeat **Step 6** or **Step 7** as required until the oil level clearly appears slightly below the center of all sight glasses.

To change the oil, proceed as follows:

1. Clear the area of bystanders, especially small children.
2. Refer to the auxiliary equipment's operator's manual and follow the standard operating procedures to warm the blower. Warm oil will assist in clearing any contaminants from the reservoir and will drain more easily and completely. Use all required protective equipment for working with hot fluids; contact with hot oil can cause severe injury.
3. Ensure all controls are in neutral, and the power source is stopped and locked-out.
4. Ensure the blower is level, reading and adjusting the oil of an unlevel blower can lead to improper lubrication levels.
5. Position a receptacle under the blower to catch the oil drainage.
6. Remove the drain plugs from each cover and headplate and allow the oil to drain.



**Figure 7-82: Headplate and cover drain plugs**

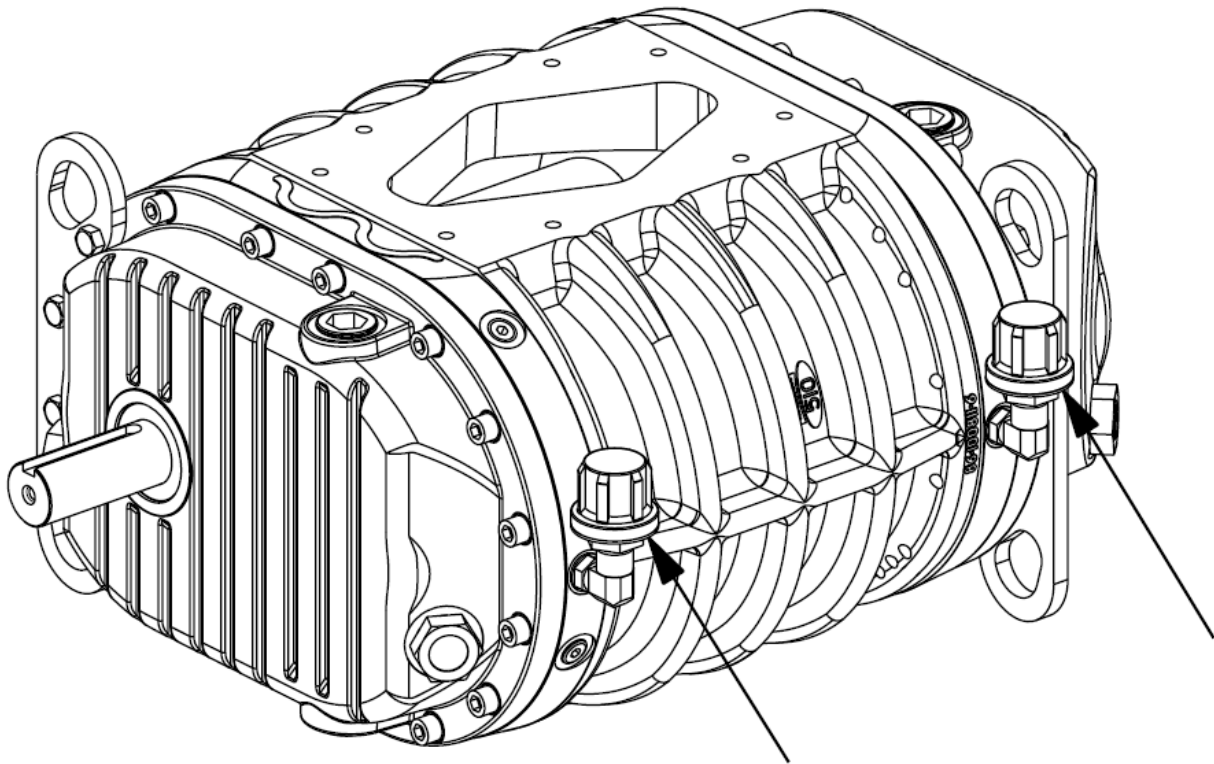
7. Flush the reservoirs with clean oil and allow several minutes for the reservoirs to completely drain.
8. Once drained, install the drain plugs and tighten to the required torque.
9. Remove the fill and oil level plugs of each reservoir as seen in **Figure 7-75**.
10. Add Walinga Super Duty Blower Oil (98-13813-6) to each reservoir until the oil just starts to come out of the oil level hole. Refer to **Table 3** in the *Maintenance Materials* section for the oil reservoir capacities.
11. Allow the oil to settle and adjust the level of each reservoir as necessary until it is slightly below the center of each sight glass as seen in **Figure 7-73**.
12. Install the oil level and fill plugs and tighten to the required torque.

### Cleaning of Breathers and Vents

The blower breathers and vents function to equalize the pressure in the oil reservoirs and cartridge seal cavities respectively in the drive and idle ends of the blower. This assists in preventing lubricating oil from entering the air stream of the blower and to prevent dust and debris from entering the lubricating oil. To maintain proper function of the breathers and vents, they must remain clean.

To clean the breathers and vents, proceed as follows:

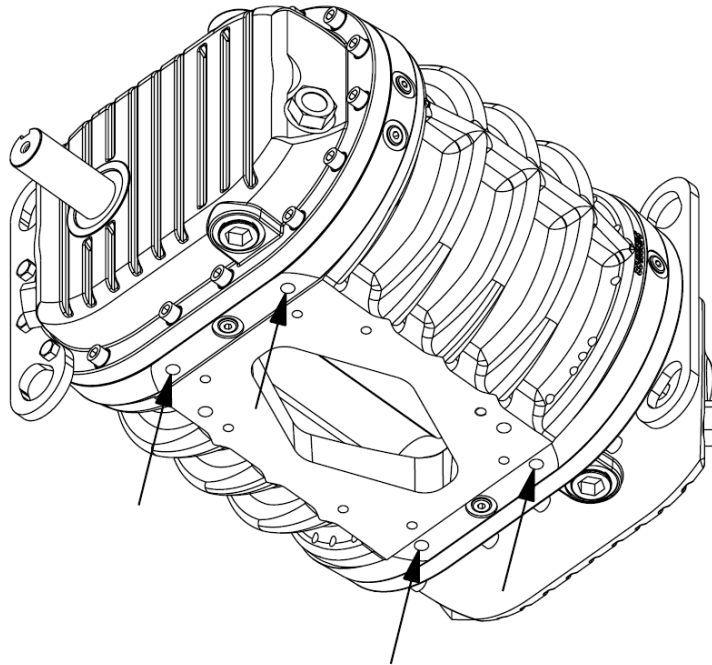
1. Clear the area of bystanders, especially small children.
2. Ensure all controls are in neutral, and the power source is stopped and locked-out.
3. Loosen and remove the breathers from the installation point.



**Figure 7-83: Breather direct mountings**

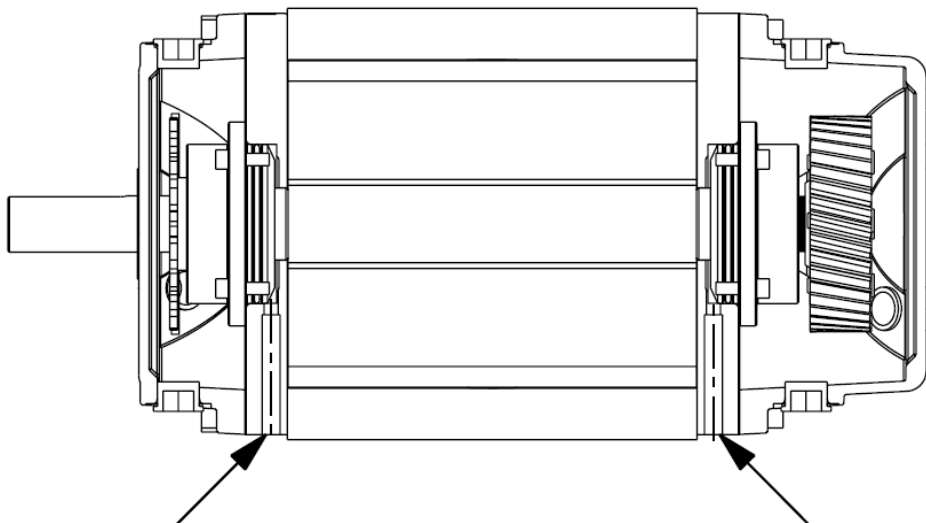
4. Use a pressurized air line to blow through the breather to dislodge and clear any dust or debris.
5. If dirt has accumulated or formed a residue within the breather, soak the breather in a solvent and use a probe as necessary to clear the breather. Blow through the breather with a pressurized air line to clear any remaining debris.

6. Use a pressurized air line to blow out the vent.



**Figure 7-84: Headplate vents**

7. If dirt has accumulated or formed a residue within the vent cavity, disassemble the blower and soak the headplate in a solvent and use a probe as necessary to clear the vent. Reassemble the blower.



**Figure 7-85: Cross-sectional view of vent cavity**

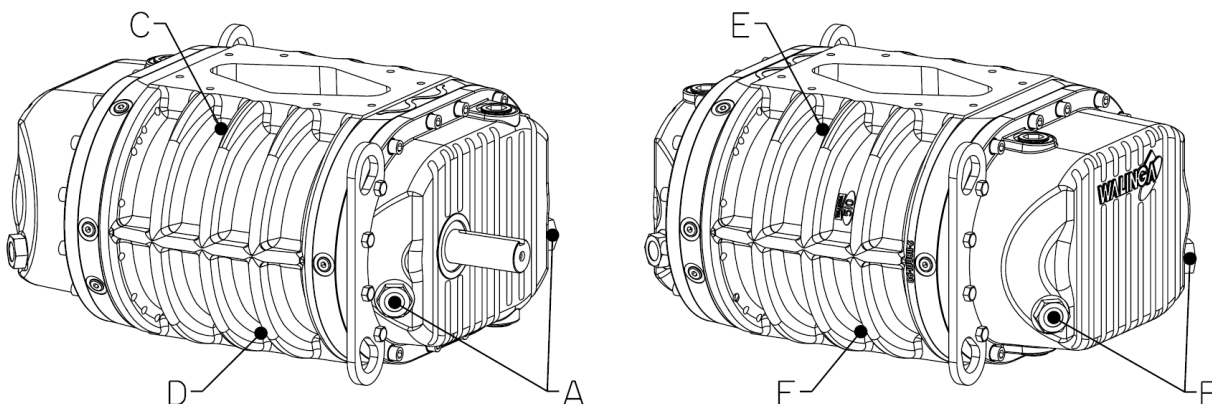
8. Reinstall the breather.

### Inspection of Operating Temperatures

Excessive heat can have adverse effects on the internal components of the blower including damage, degradation and failure. It is important to ensure the operational temperatures of the blower do not exceed those detailed in **Table 7-1** with reference to **Figure 7-86**.

**Table 7-1: Maximum operating temperatures**

Location		Temperature °F (°C)
Description	Reference	
Drive End Sight Glass(es)	<b>Fig 7-86 [A]</b>	230 (110)
Idle End Sight Glass(es)	<b>Fig 7-86 [B]</b>	235 (113)
Driving Impeller Side of Casing, Top Center	<b>Fig 7-86 [C]</b>	226 (108)
Driving Impeller Side of Casing, Bottom Center	<b>Fig 7-86 [D]</b>	293 (145)
Driven Impeller Side of Casing, Top Center	<b>Fig 7-86 [E]</b>	226 (108)
Driven Impeller Side of Casing, Bottom Center	<b>Fig 7-86 [F]</b>	284 (140)



**Figure 7-86: Temperature measurement locations**

It is important to regularly inspect the surfaces of the blower for signs of high temperatures. Along with physically measuring the temperatures during operation, a visual inspection of the blower can indicate the possibility of high operating temperatures. As steel is exposed to high temperatures, the surface color can be altered, technically referred to as tempering. The surface color changes based on the temperature as described in **Table 2**.

**Table 2: Thermal discoloration of steel**

Color	Temperature	
	[ °F ]	[ °C ]
Light Yellow	410	210
Straw	430	220
Yellow	450	230
Dark Yellow	460	240
Yellow-Brown	480	250
Red-Brown	500	260
Purple	520	270
Violet	530	280
Dark Blue	550	290
Wedgewood Blue	570	300
Light Blue	590	310
Grey Blue	610	320
Grey Green	630	330

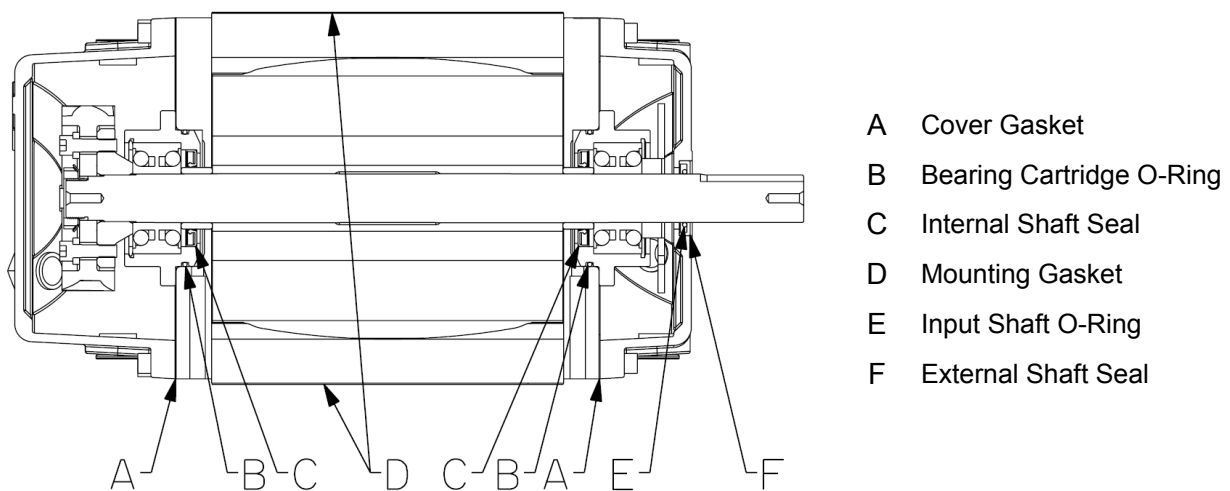
The maximum permissible operating temperatures of the blower are not sufficient to cause discoloration in the surfaces of the blower. If high temperatures are measured or noted due to discoloration, the cause for the high operating temperatures must be identified and corrected. A common cause of high operating temperatures is insufficient airflow into the blower causing a starved inlet. Ensure that any attached intake assembly, filter or muffler is clear of dirt, debris and obstructions; clean and clear as necessary. High temperatures may also be a result of insufficient lubrication. Check the drive and idle end oil reservoirs and add oil as required. Refer to *Troubleshooting* in **Section 6: Operation** for a comprehensive list of the potential causes and solutions to overheating issues.

## Inspection of Seals

Safe and efficient operation of a pneumatic system relies on well sealed components. Each joint in a pneumatic system is equipped with a seal, including the connections to and within a blower.

To check the condition of the blower seals, proceed as follows:

1. Clear the area of bystanders, especially small children.
2. During normal operation, monitor and inspect the joints of the blower for any apparent leaks, listen for any hissing, whistling or other signs of leaking.
3. If there are any signs of leaking, refer to the *Blower Disassembly* procedures and the auxiliary equipment's operator's manual to gain access to the seal in question. The seals installed in a blower are identified below.



**Figure 7-87: Blower seals**

4. Visually inspect the seal, looking for any nicks, tears, abraded areas, excessive wear, or accumulation of dirt, dust or debris.
5. Clean or replace the seal as required.
6. Refer to the *Blower Assembly* procedure and the auxiliary equipment's operator's manual to reassemble the blower. Ensure all guards are installed and secured.

## MAINTENANCE MATERIALS

### Reservoir Oil

Use Walinga Super Duty Blower Oil (98-13813-6) to fill the drive end and idle end oil reservoirs.

*Table 7-3: Oil reservoir capacities*

Model	Drive End [L (qt)]	Idle End [L (qt)]	Total [L (qt)]
506	0.95 (1.00)	1.30 (1.37)	2.25 (2.37)
510	0.95 (1.00)	1.30 (1.37)	2.25 (2.37)
510 GH	2.00 (2.11)	1.30 (1.37)	3.30 (3.48)
614	1.40 (1.48)	2.00 (2.11)	3.40 (3.59)
816	3.80 (4.02)	4.50 (4.76)	8.30 (8.78)
1020	8.00 (8.45)	9.00 (9.51)	17.00 (17.96)

### Grease

Use an SAE multi-purpose high temperature grease with extreme pressure (EP) characteristics, Unirex EP 2 (98-01959-6), for the lubrication of the drive system components and any installed grease fittings. An SAE multi-purpose lithium-based grease is also acceptable.

### Thread Treatments, Lubricants and Sealants

Use a thread sealant, Permatex High Performance Thread Sealant (92-03141-6), for fittings.

Use a medium-strength removable threadlocker, Loctite Blue 242 (92-53313-6), for the installation of the oil level sight glasses.

Use a high temperature copper based anti-seize compound, Copaslip (98-04326-6), for the installation of the cover bolts.

Use a high-strength retaining compound, Loctite Red 609 (92-03142-6), for the installation of the external shaft seal.

Use a solvent-free lubricant, Fluid Film (98-18725-6), for the installation of the bearing cartridge O-rings.

### Lubricant Storage

A blower can operate at top efficiency only if clean lubricants are used. Use clean containers to handle all lubricants, be aware of the static buildup/discharge characteristics of the storage containers. Store lubricants in a container and area protected from dust, moisture and other contaminants.

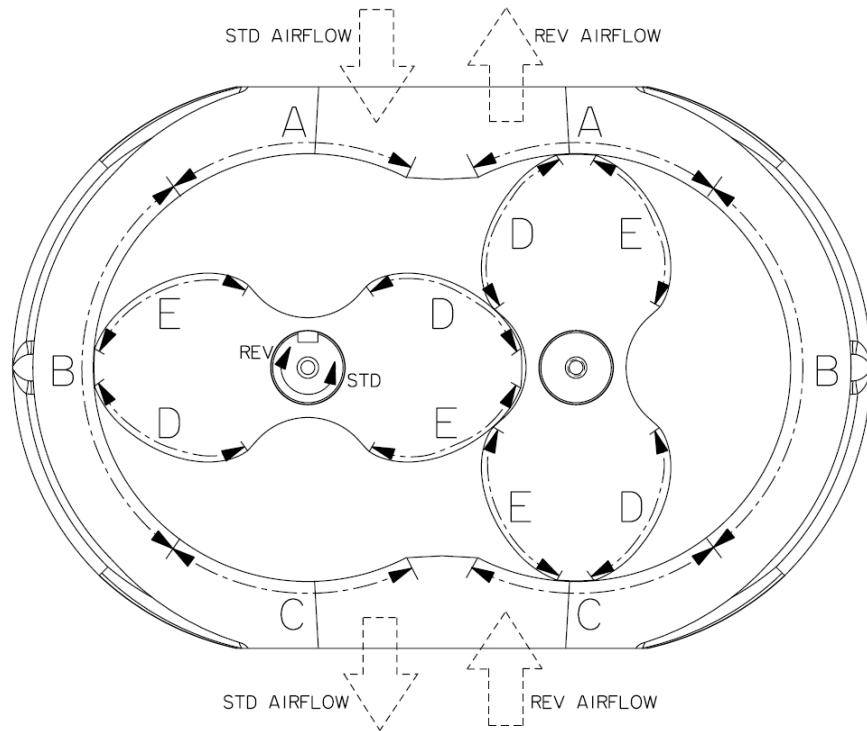
## ADJUSTMENTS

### Timing and Clearance Adjustments

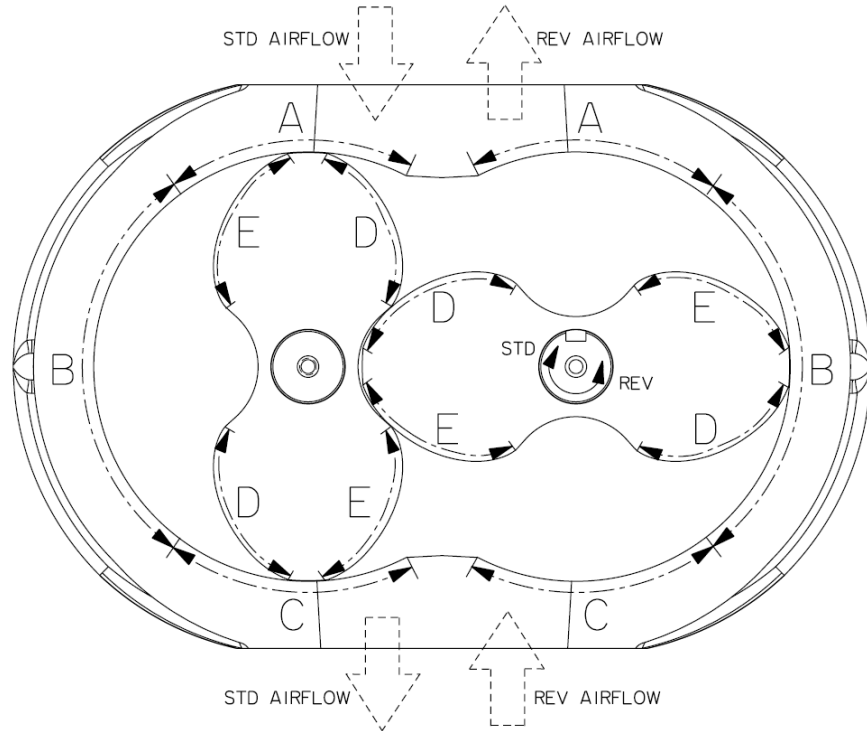
The effective operation of a blower relies heavily on maintaining specific clearances between the impellers. These clearances are precisely controlled by the timing gears, which ensures the impeller rotation is synchronized without making contact. Any issue that disrupts these clearances, such as wear, misalignment or damage to the gears, can lead to decreased performance, increased noise and potential damage to the blower. Therefore, it is essential to rectify any malfunction that affects the clearances by retiming the unit to restore the proper synchronization and clearances between the impellers, ensuring the blower operates at its optimal efficiency and preventing further complications. There are several distinctions between models that influence the timing requirements including:

- **STD:** The standard Walinga blower features advanced timing for improved performance and has standard shaft rotation, counter-clockwise for left-hand drive blowers and clockwise for right-hand drive blowers.
- **REV:** Reverse blowers have an input shaft that operates in the opposite direction, clockwise for left-hand drive blowers and counter-clockwise for right-hand drive blowers. The casing and timing clearances of these blowers are subsequently adjusted to achieve the same performance as standard blowers.
- **TIGHT:** For increased capacities, the clearances of the tight blowers have been further restricted. These blowers are only to be used in pressure-**only** or vacuum-**only** applications. Use in a vacuum and pressure application will result in interference between the impellers and casing leading to failure.
- **CTR:** Centrally or neutral timed blowers allow for operation in standard and reverse shaft rotations, capable of bi-directional rotation. However, this results in decreased overall performance.
- **GH:** All gear-head blowers have neutral timing for bi-directional operation.
- **VERT:** Blowers that are mounted vertically have slightly looser casing and end clearances.

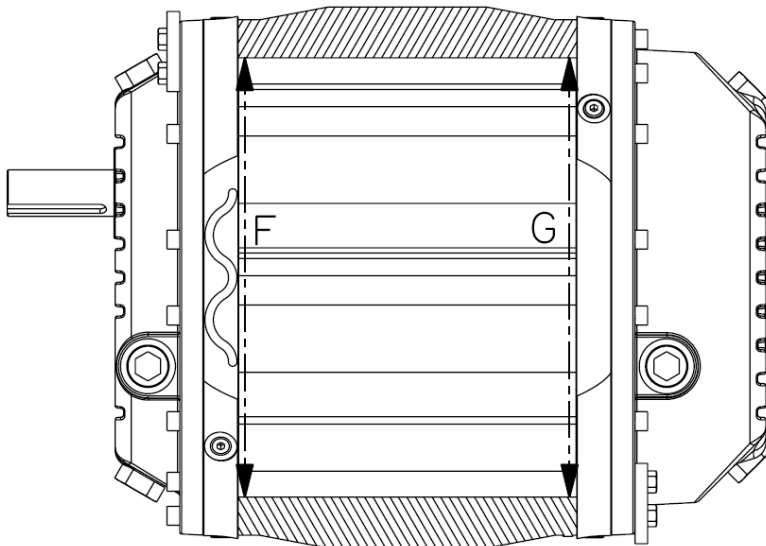
Refer to **Figure 7-88**, **Figure 7-89** and **Figure 7-90** for a visualization of the areas in which each clearance requirement is to be measured. **Table 7-4** provides the clearance requirements for each blower with reference to the aforementioned figures. It is crucial that clearance measurements are always taken when viewed from the drive end (front) of the blower. Reference may also be made to Walinga's Technical Bulletin 67866 for clearances.



**Figure 7-88: LHD blower clearance locations**



**Figure 7-89: RHD blower clearance locations**



**Figure 7-90: End clearance locations**

**Table 7-4: Blower clearances**

Model		Clearance				
Size	Distinction	Location	Ref.	Minimum [ in ]	Maximum [ in ]	
506	STD	Tip	Top	A	0.006	0.008
			Middle	B	0.005	0.008
			Bottom	C	0.005	0.007
		Timing	Leading Edge	D	0.011	0.013
			Trailing Edge	E	0.005	0.007
		End	Drive	F	0.008	0.012
			Idle	G	0.005	0.007
			Total	F+G	0.013	0.019
		506	REV	Tip	Top	A
Middle	B				0.006	0.008
Bottom	C				0.006	0.008
Timing	Leading Edge			E	0.011	0.013
	Trailing Edge			D	0.005	0.007
End	Drive			F	0.009	0.013
	Idle			G	0.006	0.008
	Total			F+G	0.015	0.021

Model		Clearance				
Size	Distinction	Location		Ref.	Minimum [ in ]	Maximum [ in ]
506	VERT	Tip	Top	A	0.006	0.008
			Middle	B	0.006	0.008
			Bottom	C	0.006	0.008
		Timing	Leading Edge	D	0.011	0.013
			Trailing Edge	E	0.005	0.007
		End	Drive	F	0.009	0.013
			Idle	G	0.006	0.008
			Total	F+G	0.015	0.021
		510	STD	Tip	Top	A
Middle	B				0.006	0.009
Bottom	C				0.006	0.008
Timing	Leading Edge			D	0.013	0.015
	Trailing Edge			E	0.005	0.008
End	Drive			F	0.009	0.013
	Idle			G	0.006	0.008
	Total			F+G	0.015	0.021
510	REV			Tip	Top	A
		Middle	B		0.006	0.009
		Bottom	C		0.008	0.010
		Timing	Leading Edge	E	0.013	0.015
			Trailing Edge	D	0.005	0.008
		End	Drive	F	0.009	0.013
			Idle	G	0.006	0.008
			Total	F+G	0.015	0.021
		510	TIGHT	Tip	Top	A
Middle	B				0.005	0.008
Bottom	C				0.005	0.007
Timing	Leading Edge			D	0.011	0.013
	Trailing Edge			E	0.005	0.007
End	Drive			F	0.008	0.012
	Idle			G	0.005	0.007
	Total			F+G	0.014	0.019

Model		Clearance				
Size	Distinction	Location		Ref.	Minimum [ in ]	Maximum [ in ]
510	CTR	Tip	Top	A	0.007	0.009
			Middle	B	0.006	0.009
			Bottom	C	0.007	0.009
		Timing	Leading Edge	D	0.012	0.014
			Trailing Edge	E	0.012	0.014
		End	Drive	F	0.009	0.013
			Idle	G	0.006	0.008
			Total	F+G	0.015	0.021
		510	GH	Tip	Top	A
Middle	B				0.006	0.009
Bottom	C				0.007	0.009
Timing	Leading Edge			D	0.009	0.012
	Trailing Edge			E	0.009	0.012
End	Drive			F	0.009	0.013
	Idle			G	0.006	0.008
	Total			F+G	0.015	0.021
614	STD			Tip	Top	A
		Middle	B		0.009	0.012
		Bottom	C		0.008	0.010
		Timing	Leading Edge	D	0.015	0.017
			Trailing Edge	E	0.007	0.010
		End	Drive	F	0.012	0.014
			Idle	G	0.008	0.010
			Total	F+G	0.020	0.024
		614	REV	Tip	Top	A
Middle	B				0.009	0.012
Bottom	C				0.012	0.014
Timing	Leading Edge			E	0.015	0.017
	Trailing Edge			D	0.007	0.010
End	Drive			F	0.012	0.014
	Idle			G	0.008	0.010
	Total			F+G	0.020	0.024

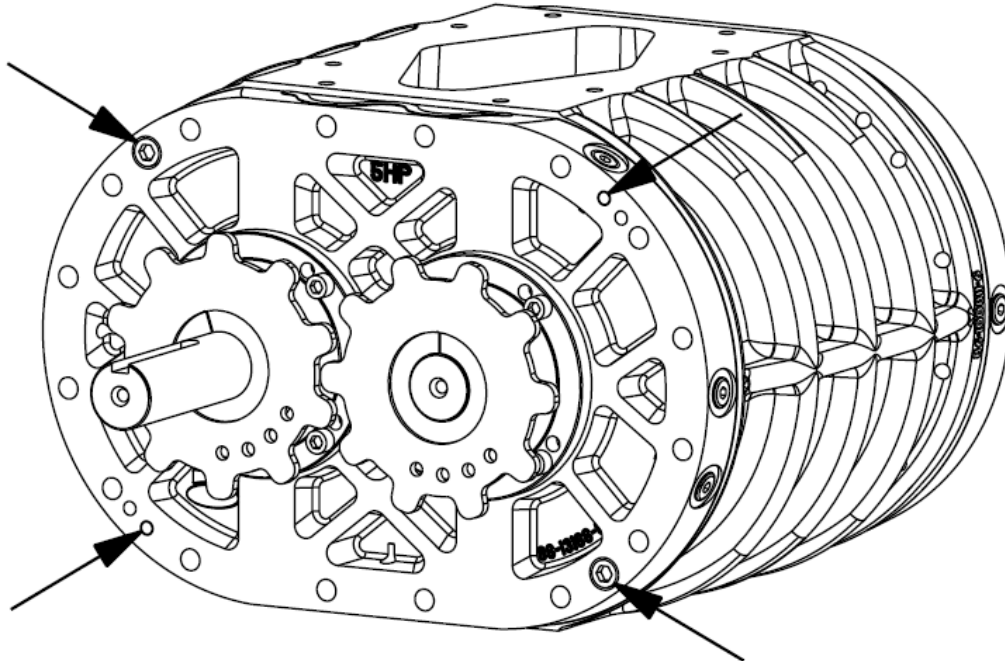
Model		Clearance				
Size	Distinction	Location	Ref.	Minimum [ in ]	Maximum [ in ]	
614	TIGHT	Tip	Top	A	0.009	0.011
			Middle	B	0.007	0.010
			Bottom	C	0.007	0.009
		Timing	Leading Edge	D	0.013	0.015
			Trailing Edge	E	0.005	0.008
		End	Drive	F	0.010	0.013
			Idle	G	0.007	0.009
			Total	F+G	0.017	0.022
		816	STD	Tip	Top	A
Middle	B				0.013	0.017
Bottom	C				0.009	0.011
Timing	Leading Edge			D	0.024	0.028
	Trailing Edge			E	0.006	0.010
End	Drive			F	0.016	0.022
	Idle			G	0.009	0.012
	Total			F+G	0.025	0.034
1020	STD			Tip	Top	A
		Middle	B		0.015	0.020
		Bottom	C		0.010	0.014
		Timing	Leading Edge	D	0.025	0.028
			Trailing Edge	E	0.016	0.021
		End	Drive	F	0.020	0.024
			Idle	G	0.010	0.012
			Total	F+G	0.030	0.036

To check the **tip** clearances, proceed as follows:

1. Clear the area of bystanders, especially small children.
2. Ensure all controls are in neutral, and the power source is stopped and locked-out.
3. Allow the blower to cool and ensure the temperature has stabilized. All clearance measurements must be made with all components within 9°F (5°C) of each other.
4. Slide a feeler gauge equivalent to the minimum clearance measurement for the top tip clearance with reference to **Table 7-4** between the impellers and all areas identified in **Figure 7-88** or **Figure 7-89**, rotating the impellers as necessary.
5. If the minimum clearance feeler gauge does not fit between the impeller and casing according to a standard feeler gauge test, adjust the tip clearances.
6. If the minimum clearance feeler gauge does not pass the standard feeler gauge test, proceed to insert progressively larger feeler gauges into the identified areas until the standard feeler gauge test is passed.
7. If the passing feeler gauge is less than the stated maximum clearance in **Table 7-4**, the clearance is acceptable, if the passing feeler gauge is larger than the maximum permissible clearance, adjust the tip clearances.
8. Repeat **Step 4** to **Step 7** to measure the middle tip clearance.
9. Repeat **Step 4** to **Step 7** to measure the bottom tip clearance.

To adjust the **tip** clearances, proceed as follows:

1. Clear the area of bystanders, especially small children.
2. Ensure all controls are in neutral, and the power source is stopped and locked-out.
3. Allow the blower to cool and ensure the temperature has stabilized. All clearance measurements must be made with all components within 9°F (5°C) of each other.
4. Refer to *Blower Disassembly* to remove both covers and any components as necessary.
5. Remove the dowel pins and loosen the cap screws securing the headplates.

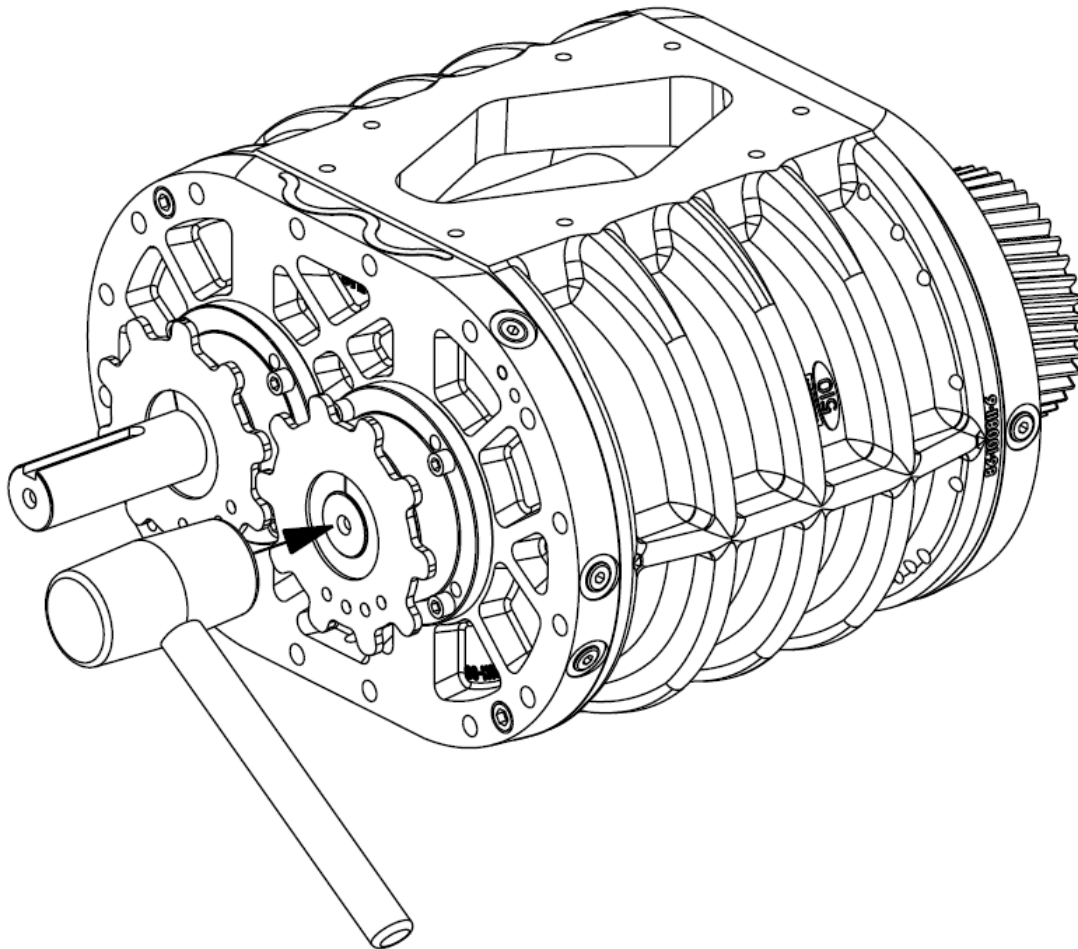


**Figure 7-91: Headplate loosening**

6. Tap the headplates to center with the casing vertically and horizontally.
7. Tighten the cap screws to secure the headplates in place. Measure all tip clearances.
8. If the required clearances are achieved, drill and ream new holes for the dowel pins and press fit new dowel pins in place.
9. If the required clearances are not met, repeat **Step 5** to **Step 7** until required clearances are achieved. If the required clearances can not be met, contact your local Walinga dealer or representative.
10. Check the timing and end clearances and refer to the *Blower Assembly* section to reassemble all components of the blower. Ensure all fasteners are tightened to the required torque.

To check the **end** clearances, proceed as follows:

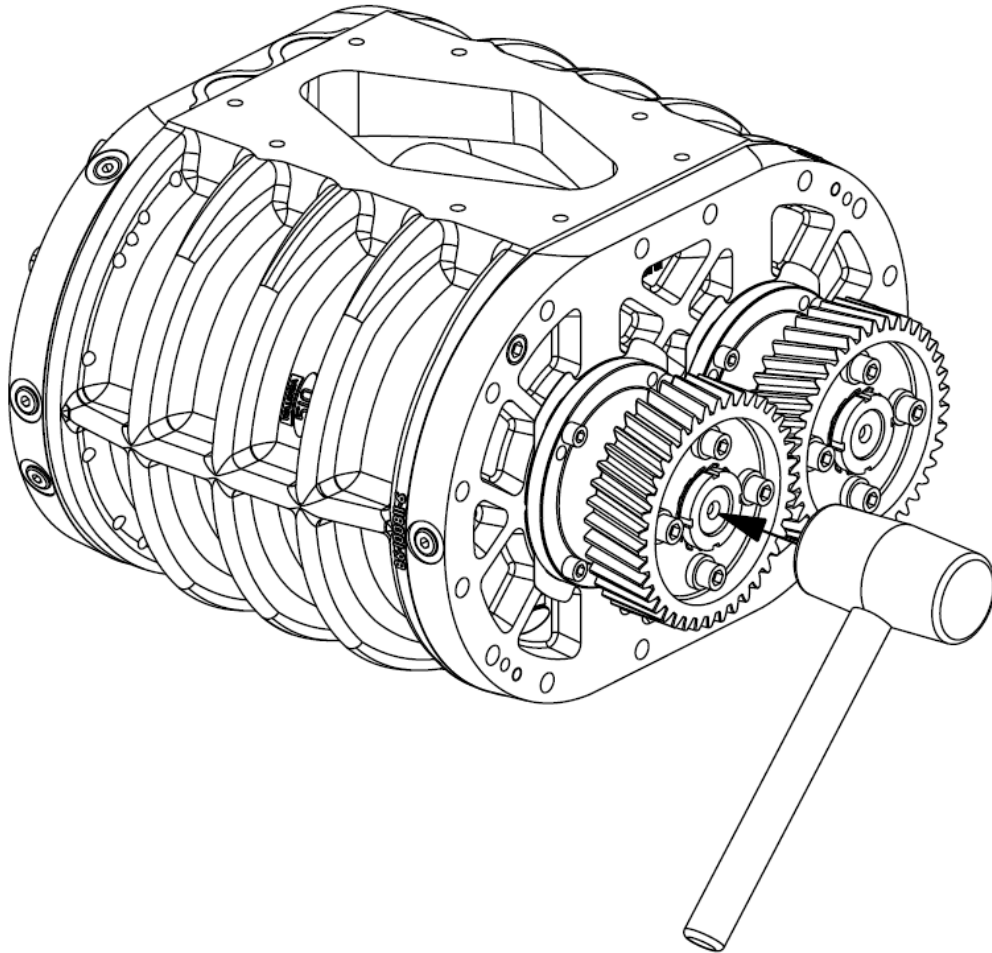
1. Clear the area of bystanders, especially small children.
2. Ensure all controls are in neutral, and the power source is stopped and locked-out.
3. Allow the blower to cool and ensure the temperature has stabilized. All clearance measurements must be made with all components within 9°F (5°C) of each other.
4. Refer to *Blower Disassembly* to remove both covers and any components as necessary.
5. Use a soft hammer or mallet to tap the drive end of the driven shaft to eliminate the inherent play in the bearing assemblies.



**Figure 7-92: Elimination of idle end play**

6. Slide a feeler gauge equivalent to the minimum clearance measurement for the idle end clearance with reference to **Table 7-4** between the impellers and the areas identified in **Figure 7-90**, rotating the impellers to check all areas.
7. If the minimum clearance feeler gauge does not fit between the impeller and headplate according to a standard feeler gauge test, adjust the end clearances.

8. If the minimum clearance feeler gauge does not pass the standard feeler gauge test, proceed to insert progressively larger feeler gauges into the identified areas until the standard feeler gauge test is passed.
9. If the passing feeler gauge is less than the stated maximum clearance in **Table 7-4**, the clearance is acceptable, if the passing feeler gauge is larger than the maximum permissible clearance, adjust the end clearances.
10. Use a soft hammer or mallet to tap the idle end of the driven shaft to eliminate the inherent play in the bearing assemblies.

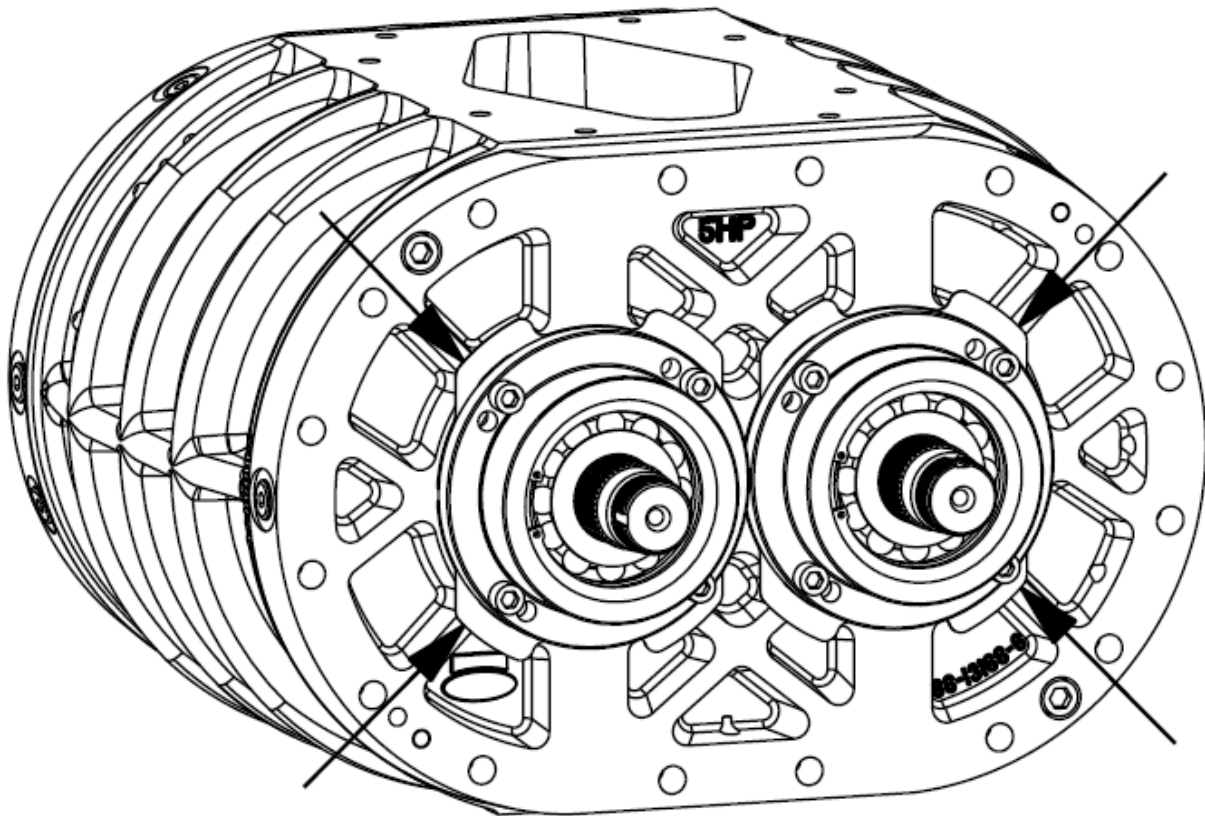


**Figure 7-93: Elimination of drive end play**

11. Repeat **Step 6** to **Step 9** to measure the drive end clearance.
12. Ensure the sum of the drive end and idle end clearance does not exceed the maximum permissible total end clearance.

To adjust the **end** clearances, proceed as follows:

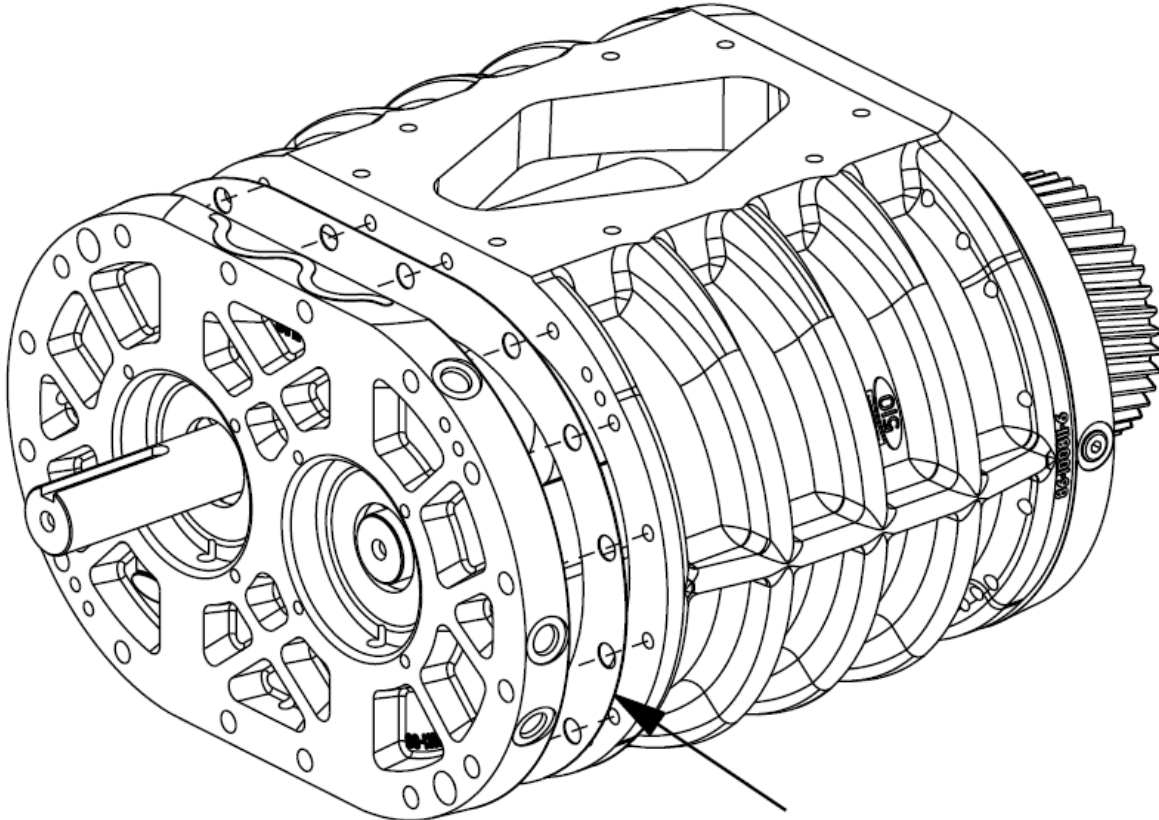
1. Clear the area of bystanders, especially small children.
2. Ensure all controls are in neutral, and the power source is stopped and locked-out.
3. Allow the blower to cool and ensure the temperature has stabilized. All clearance measurements must be made with all components within 9°F (5°C) of each other.
4. Refer to *Blower Disassembly* to remove the covers and any components as necessary.
5. To adjust the idle end clearance, install or remove shims between the idle end bearing cartridges and headplate as required. If the clearance is too tight, remove shims from the cartridges; if the clearance is too loose, add shims to the cartridges. Ensure the same thickness of shims are installed on the top and bottom of each cartridge.



**Figure 7-94: Idle end bearing cartridge shims**

6. Measure the idle end clearance. If the required clearance can not be met, contact your local Walinga dealer or representative.

7. To adjust the drive end clearance, install or remove a trimmed precision paper between the drive end headplate and casing as required. If the clearance is too tight, add a trimmed precision paper; if the clearance is too loose, remove a precision paper if installed.



**Figure 7-95: Drive end headplate precision paper installation**

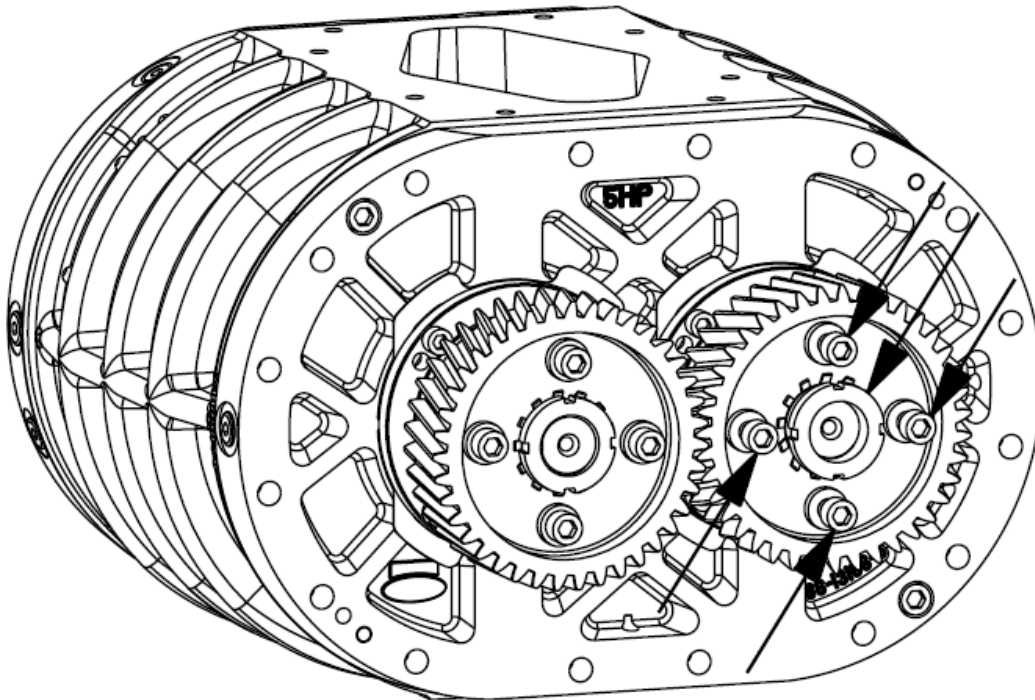
8. Measure the end clearances. If the required clearance can not be met, contact your local Walinga dealer or representative.
9. Check the timing and tip clearances and refer to the *Blower Assembly* section to reassemble all components of the blower. Ensure all fasteners are tightened to the required torque.

To check the **timing** clearances, proceed as follows:

1. Clear the area of bystanders, especially small children.
2. Ensure all controls are in neutral, and the power source is stopped and locked-out.
3. Allow the blower to cool and ensure the temperature has stabilized. All clearance measurements must be made with all components within 9°F (5°C) of each other.
4. Rotate the driving impeller by hand to measure the leading edge clearance with reference to **Figure 7-88** or **Figure 7-89**.
5. Slide a feeler gauge equivalent to the minimum clearance measurement for the leading edge clearance with reference to **Table 7-4** between the impellers in all areas identified in **Figure 7-88** or **Figure 7-89**, rotating the impellers as necessary.
6. If the minimum clearance feeler gauge does not fit between the impellers according to a standard feeler gauge test, adjust the timing clearances.
7. If the minimum clearance feeler gauge does not pass the standard feeler gauge test, proceed to insert progressively larger feeler gauges into the identified areas until the standard feeler gauge test is passed.
8. If the passing feeler gauge is less than the stated maximum clearance in **Table 7-4**, the clearance is acceptable, if the passing feeler gauge is larger than the maximum permissible clearance, adjust the timing clearances.
9. Repeat **Step 4** to **Step 8** to measure the trailing edge clearance.

To adjust the **timing** clearances, proceed as follows:

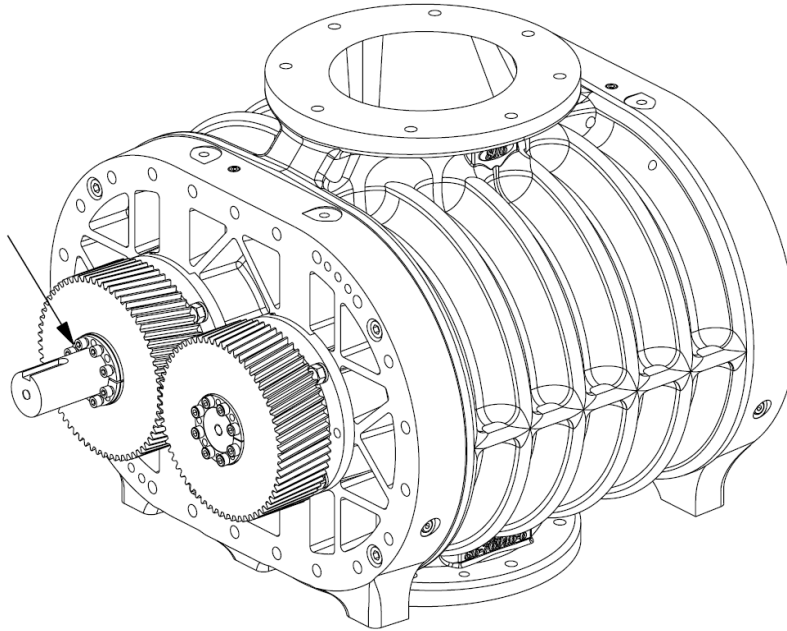
1. Clear the area of bystanders, especially small children.
2. Ensure all controls are in neutral, and the power source is stopped and locked-out.
3. Allow the blower to cool and ensure the temperature has stabilized. All clearance measurements must be made with all components within 9°F (5°C) of each other.
4. Refer to *Blower Disassembly* to remove the covers and any components as necessary.
5. For **506**, **510** and **614** models only:
  - a. Loosen the fasteners and lock nut of the driving impeller timing gear.



**Figure 7-96: Driving impeller timing gear fasteners**

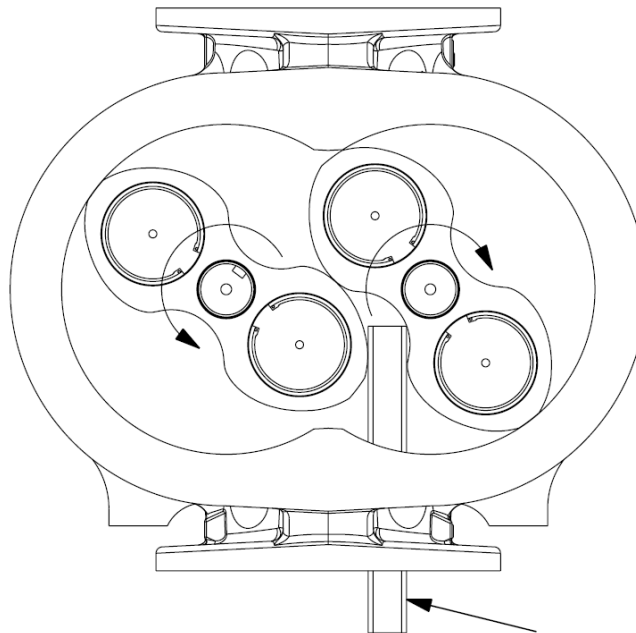
- b. Insert a feeler gauge equivalent to the minimum leading edge clearance as specified in **Table 7-4** between the two impellers with reference to **Figure 7-88** or **Figure 7-89**.
- c. Position and secure the two impellers securely against the feeler gauge and tighten the fasteners to secure the driving impeller timing gear in place.
- d. Rotate the impellers to check the leading edge and trailing edge clearances.
- e. If there are any places where the clearance is too tight, loosen the fasteners of the timing gear until finger tight. Carefully tap on the timing gear using an aluminum bar and hammer to shift the position of the gear on the hub.
- f. Install and tighten the timing gear fasteners with new timing washers. Install and tighten the lock washer and nut.

6. For **816** and **1020** models only:
  - a. Loosen the locking bushing of the driving impeller.



**Figure 7-97: Driving impeller locking bushing loosening**

- b. Insert a plank into the blower outlet against the driven impeller lobe to prevent the impeller from rotating.



**Figure 7-98: Driven impeller immobilization**

- c. Insert a feeler gauge that is 0.005 in (0.127 mm) smaller than the minimum specified in **Table 7-4** for the leading edge timing clearance between the two impellers. Ensure the impellers are positioned to measure the leading edge clearance with reference to **Figure 7-88** or **Figure 7-89**.
  - d. Insert a 0.004 in (0.102 mm) feeler gauge between the teeth of the timing gears on the leading side of the driving impeller to achieve the appropriate backlash spacing.
  - e. In a clockwise pattern, begin to tighten the locking screws of the bushing, turning each screw only a quarter turn (90°) at a time and repeating the pattern until a torque of 20 lb-ft (27 Nm) is reached.
  - f. Remove the plank from the blower outlet and measure all timing clearances.
  - g. If the clearances are within the specifications, continue the tightening pattern of both locking bushings until the specified torque is reached.
  - h. If clearances do not meet the specifications, loosen the driving impeller locking bushing and repeat **Step 6a** through **Step 6f**, changing the feeler gauge used in **Step 6c** as follows:
    - i. If the clearances are too tight, use a larger feeler gauge.
    - ii. If the clearances are too loose, use a smaller feeler gauge.
  - i. Ensure the fasteners of both locking bushings are tightened to the required torque.
7. Measure the timing clearances. If the required clearance can not be met, contact your local Walinga dealer or representative.
  8. Check the casing and end clearances and refer to the *Blower Assembly* section to reassemble all components of the blower. Ensure all fasteners are tightened to the required torque.



# Specifications

---

## BLOWER MODELS

---

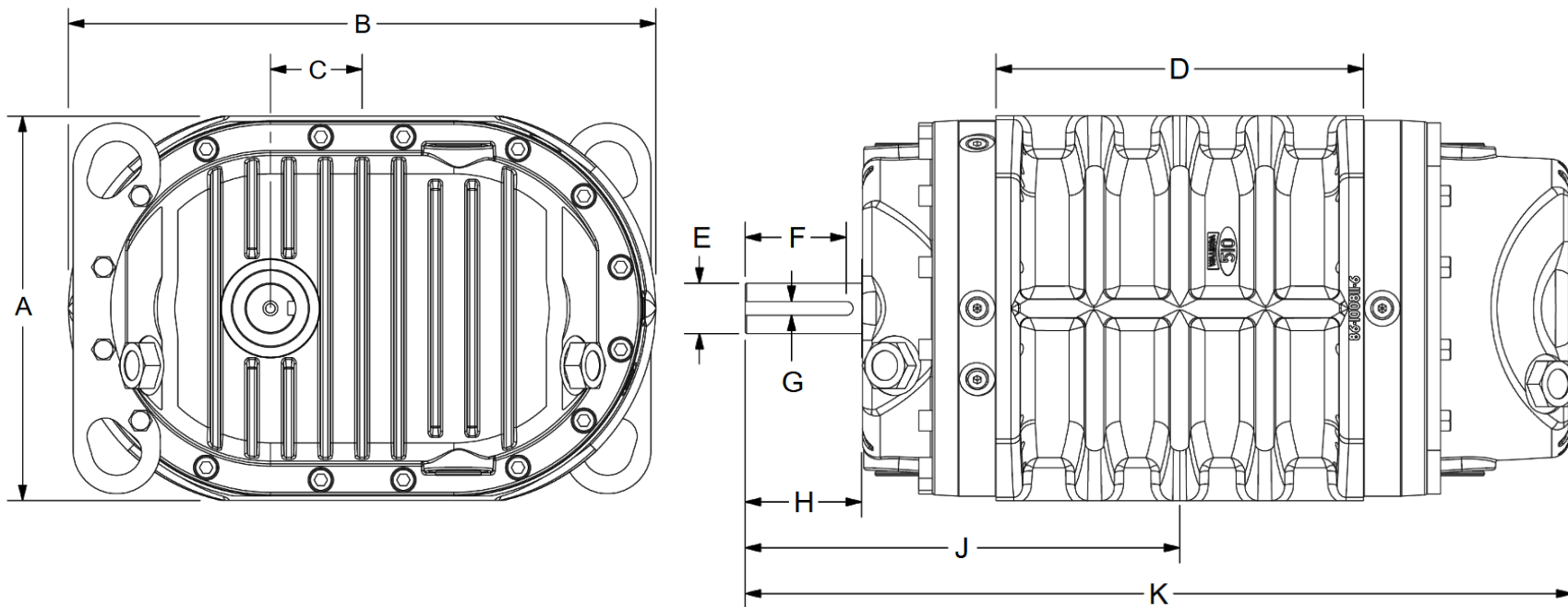
TECHNICAL DATA

			506	510	614	816	1020
<b>Operation</b>	<b>Max. Flow</b>	ft <sup>3</sup> /min (m <sup>3</sup> /min)	734.4 (20.8)	1224.0 (34.7)	2055.0 (58.2)	3402.0 (96.3)	4820.4 (136.5)
	<b>Max. Pressure</b>	psi (kPa)	15.0 (103.4)	15.0 (103.4)	15.0 (103.4)	15.0 (103.4)	15.0 (103.4)
	<b>Max. Vacuum</b>	in Hg (kPa)	16 (54.2)	16 (54.2)	16 (54.2)	16 (54.2)	16 (54.2)
	<b>Speed</b>	rpm	1270 - 3600	1270 - 3600	1270 - 3000	1270 - 2250	1270 - 1800
<b>Dimensions</b> (Fig. 8-1)	<b>Weight<sup>+</sup></b>	lbs (kg)	171 (77.6)	263 (119.3)	457 (207.3)	1157 (524.8)	2268 (1028.7)
	<b>Capacity</b>	ft <sup>3</sup> /rev (L/rev)	0.204 (5.78)	0.340 (9.63)	0.685 (19.40)	1.512 (42.82)	2.678 (75.83)
	<b>A</b>	in (mm)	10.50 (266.7)	10.50 (266.7)	13.00 (330.2)	22.00 (558.8)	22.50 (571.5)
	<b>B</b>	in (mm)	15.71 (399.0)	16.01 (406.7)	18.76 (476.5)	24.93 (633.2)	31.50 (800.1)
	<b>C</b>	in (mm)	2.50 (63.5)	2.50 (63.5)	3.00 (76.2)	4.00 (101.6)	5.00 (127.0)
	<b>D</b>	in (mm)	6.00 (152.4)	10.00 (254.0)	14.00 (355.6)	16.00 (406.4)	20.00 (508.0)
	<b>E</b>	in (mm)	1.375 (34.9)	1.375 (34.9)	1.56 (39.6)	2.00 [50.8]	2.50 (63.5)
<b>F</b>	in (mm)	3.06 (77.7)	2.75 (69.9)	1.75 (44.5)	2.00 (50.8)	3.50 (88.9)	

<b>G</b>	<b>in (mm)</b>	0.375 (9.5)	0.375 (9.5)	0.375 (9.5)	0.50 (12.7)	0.625 (15.9)
<b>H*</b>	<b>in (mm)</b>	3.46 (87.9)	3.20 (81.3)	2.24 (56.9)	2.86 (72.6)	5.10 (129.5)
<b>J*</b>	<b>in (mm)</b>	10.09 (256.3)	11.83 (300.5)	13.21 (335.5)	18.74 (476.0)	24.35 (618.5)
<b>K*</b>	<b>in (mm)</b>	19.10 (485.1)	22.45 (570.2)	26.56 (674.6)	35.02 (889.5)	44.01 (1117.9)

† Dry weight, does not include oil

\* Short shaft model



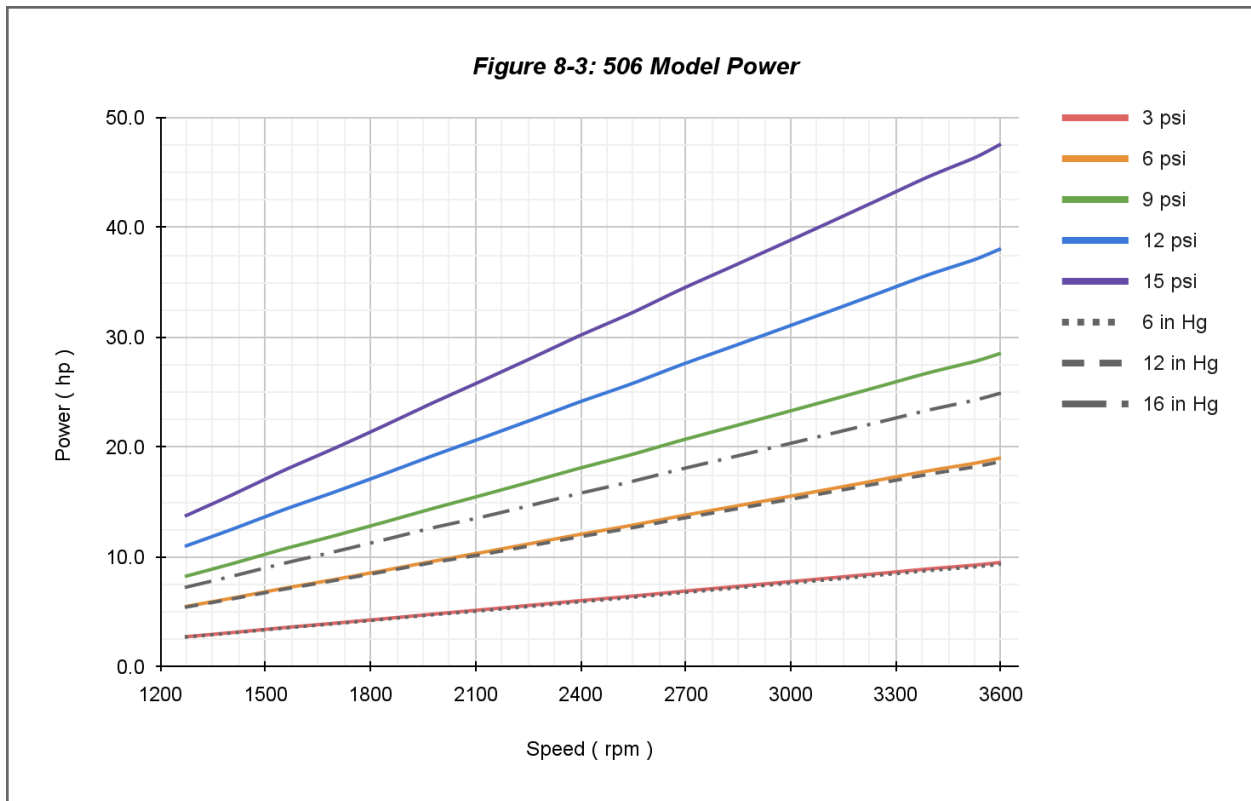
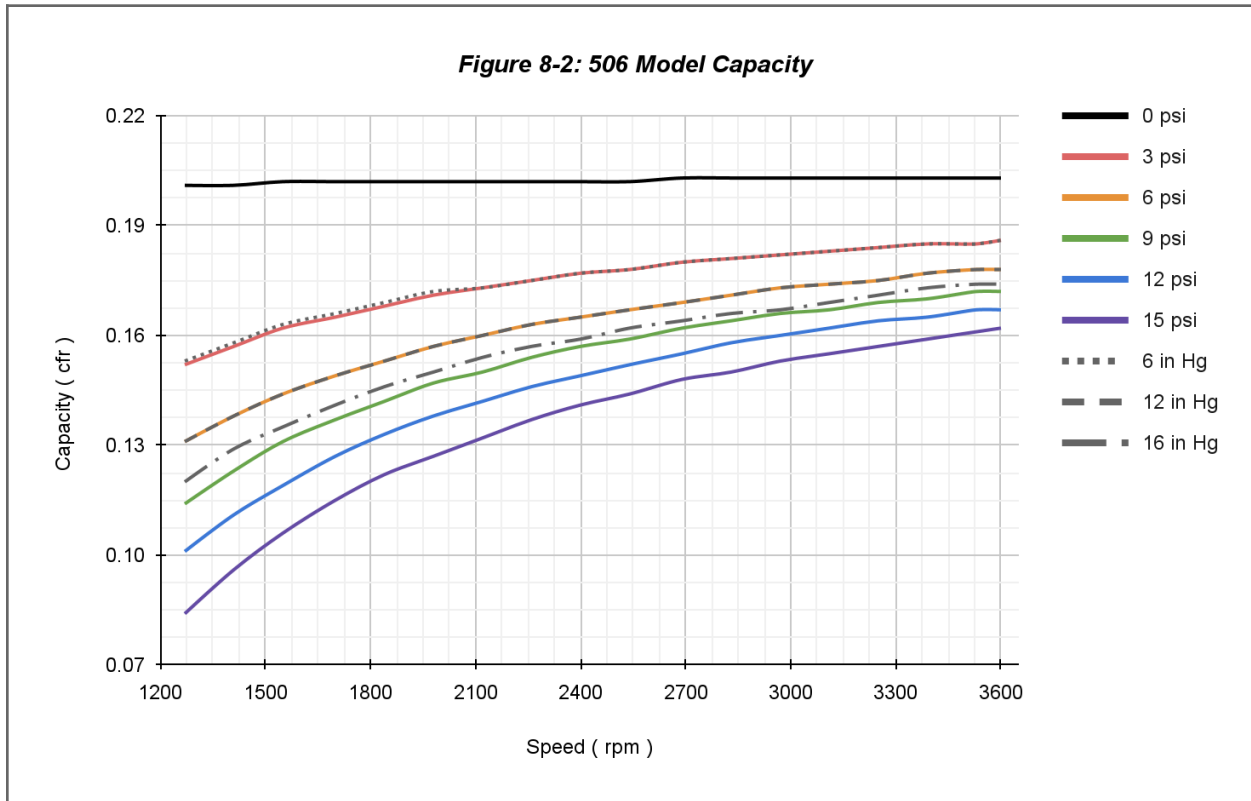
**Figure 8-1: Blower reference dimensions**

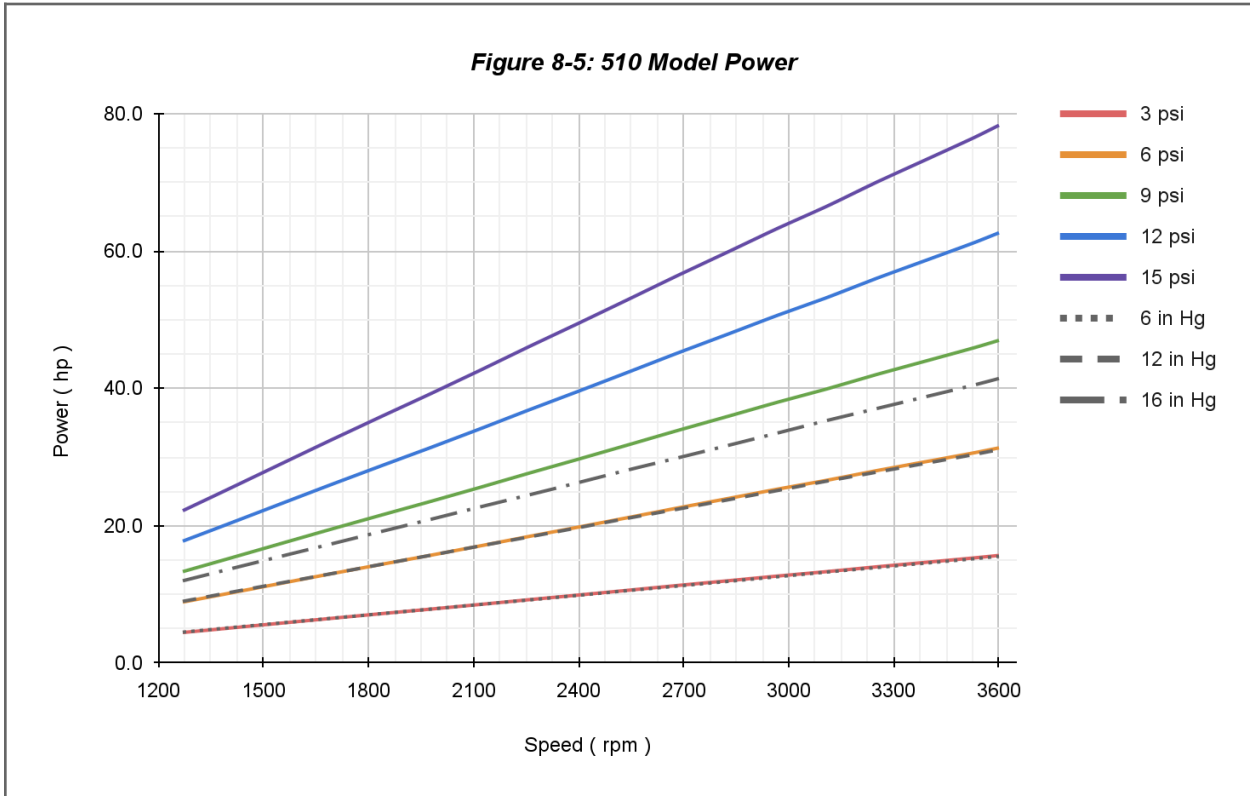
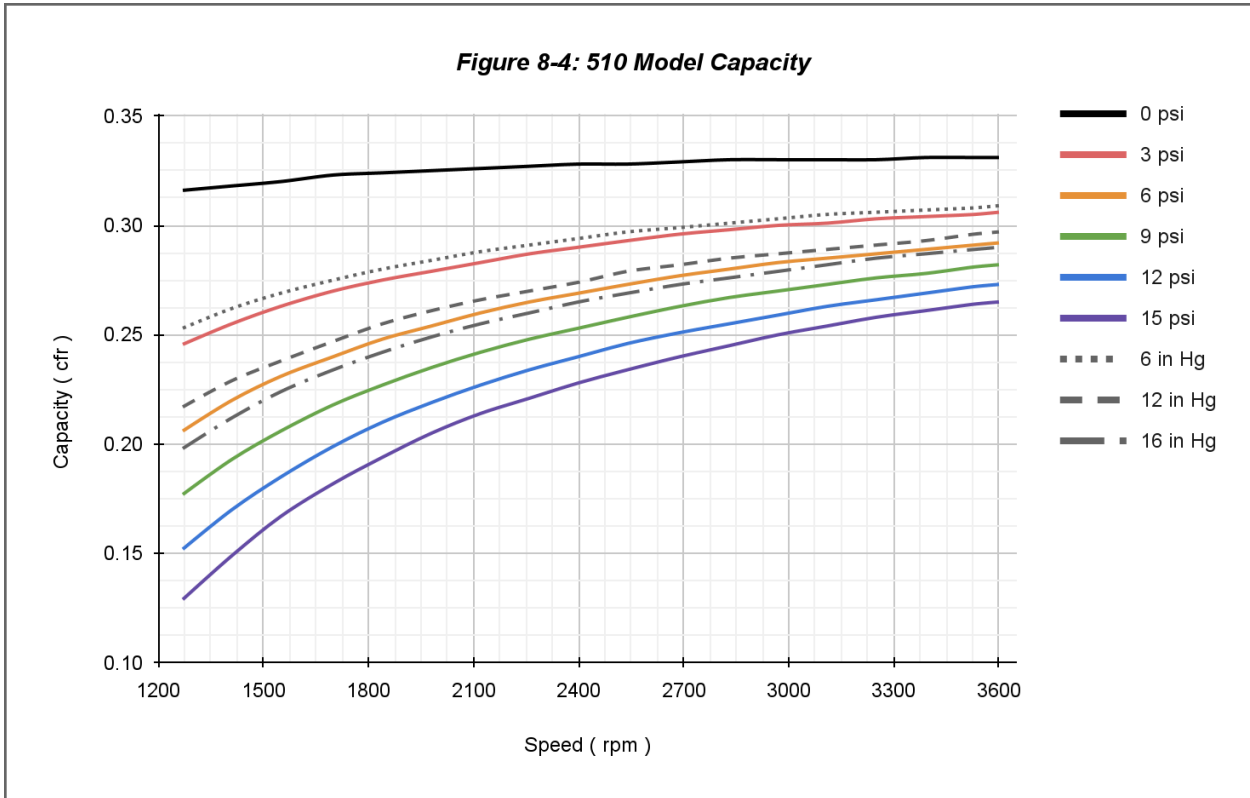
**Table 8-1: Blower performance data**

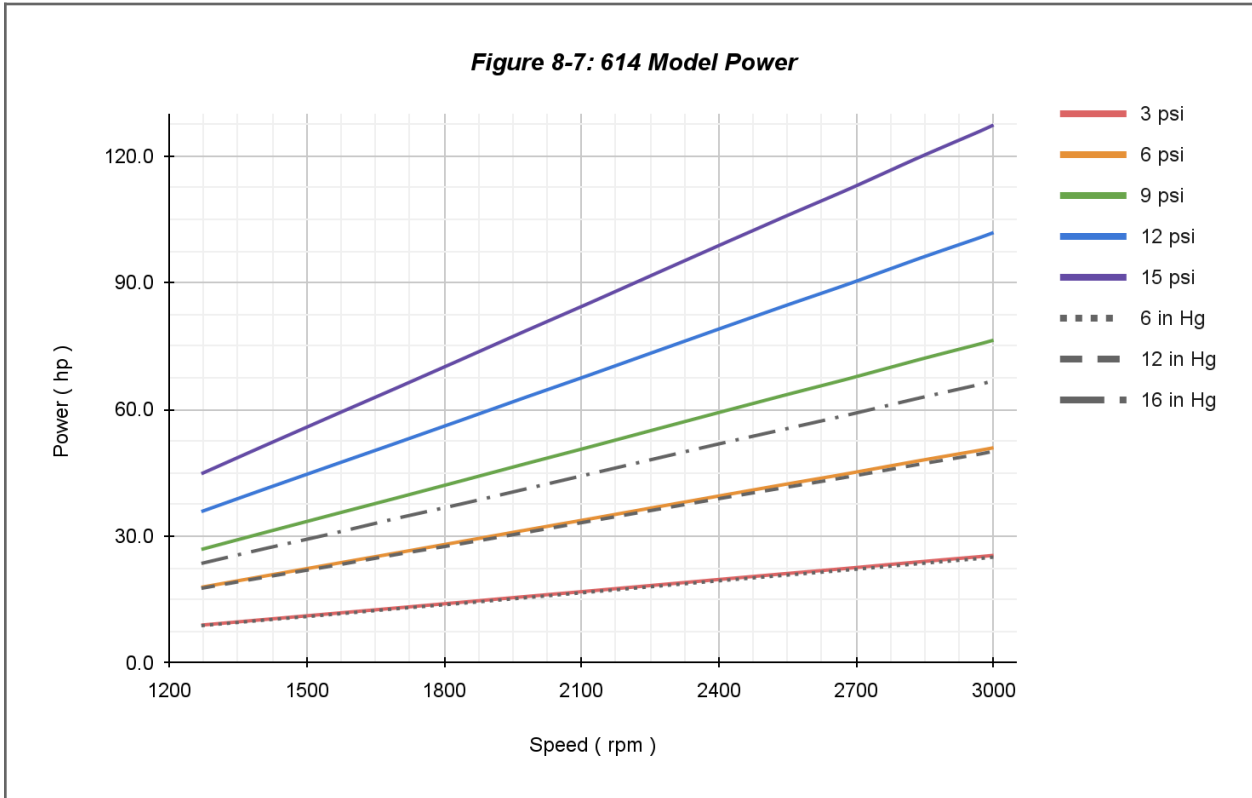
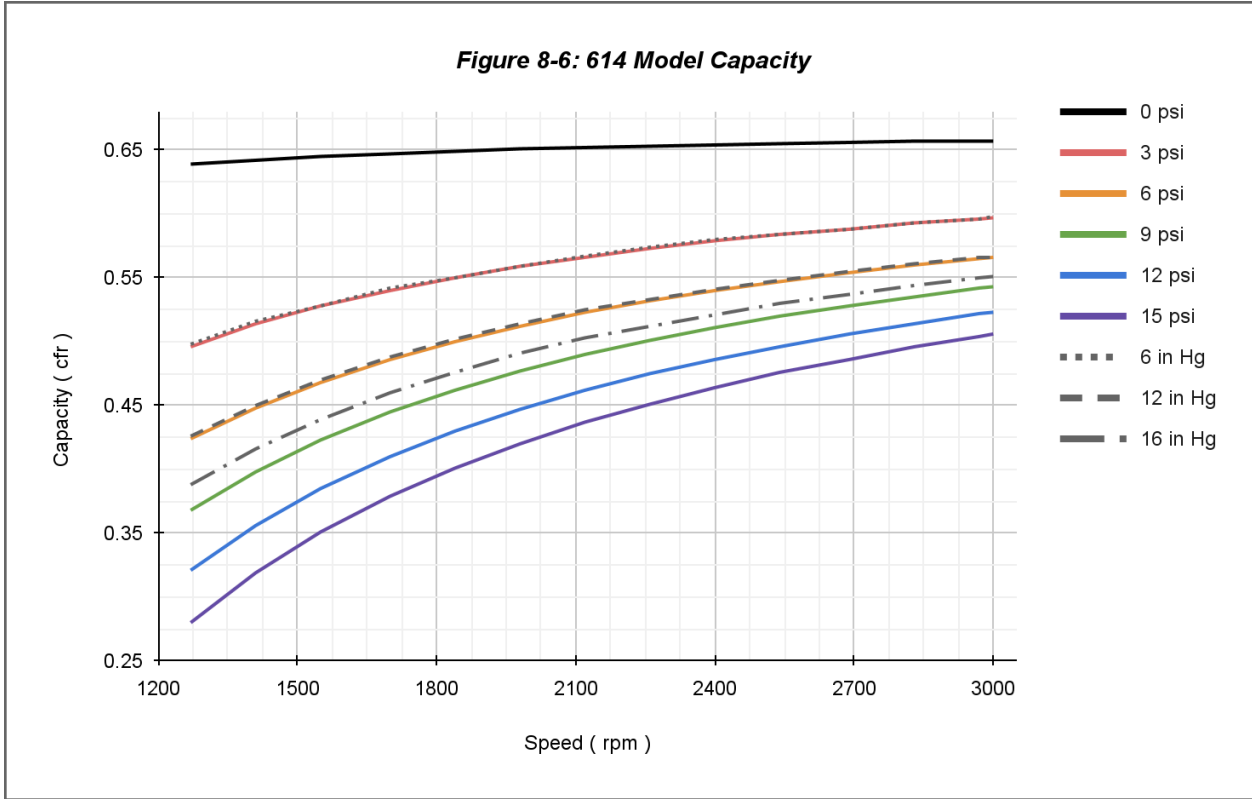
Model	Pressure	Speed (rpm)																	
		1270		1550		1840		2120		2400		2690		2970		3250		3600	
		CFR	HP	CFR	HP	CFR	HP	CFR	HP	CFR	HP	CFR	HP	CFR	HP	CFR	HP	CFR	HP
506	3 psi	0.152	2.7	0.162	3.6	0.168	4.4	0.173	5.2	0.177	6.0	0.180	6.9	0.182	7.7	0.184	8.5	0.186	9.5
	6 psi	0.131	5.5	0.144	7.1	0.153	8.8	0.160	10.4	0.165	12.1	0.169	13.8	0.173	15.4	0.175	17.0	0.178	19.0
	9 psi	0.114	8.2	0.131	10.7	0.142	13.2	0.150	15.6	0.157	18.1	0.162	20.7	0.166	23.1	0.169	25.5	0.172	28.6
	12 psi	0.101	11.0	0.119	14.3	0.133	17.6	0.142	20.9	0.149	24.2	0.155	27.5	0.160	30.7	0.164	34.0	0.167	38.1
	15 psi	0.084	13.7	0.106	17.9	0.122	22.0	0.132	26.1	0.141	30.2	0.148	34.4	0.153	38.4	0.157	42.5	0.162	47.6
	6 in Hg	0.153	2.7	0.163	3.5	0.169	4.3	0.173	5.1	0.177	5.9	0.180	6.8	0.182	7.6	0.184	8.4	0.186	9.4
	12 in Hg	0.131	5.4	0.144	7.1	0.153	8.7	0.160	10.2	0.165	11.9	0.169	13.5	0.173	15.1	0.175	16.7	0.178	18.7
	16 in Hg	0.120	7.2	0.135	9.4	0.146	11.6	0.154	13.7	0.159	15.8	0.164	18.0	0.167	20.1	0.171	22.3	0.174	24.9
510	3 psi	0.246	4.4	0.263	5.8	0.275	7.2	0.283	8.5	0.290	9.9	0.296	11.3	0.300	12.7	0.303	14.0	0.306	15.7
	6 psi	0.206	8.9	0.231	11.6	0.248	14.4	0.260	17.1	0.269	19.8	0.277	22.6	0.283	25.3	0.287	28.0	0.292	31.3
	9 psi	0.177	13.3	0.206	17.4	0.227	21.6	0.242	25.6	0.253	29.7	0.263	34.0	0.270	38.0	0.276	42.0	0.282	47.0
	12 psi	0.152	17.7	0.185	23.2	0.210	28.8	0.227	34.1	0.240	39.6	0.251	45.3	0.259	50.7	0.266	56.0	0.273	62.7
	15 psi	0.129	22.2	0.167	29.0	0.194	36.0	0.214	42.7	0.228	49.5	0.240	56.6	0.250	63.4	0.258	70.0	0.265	78.3
	6 in Hg	0.253	4.5	0.269	5.8	0.280	7.2	0.288	8.5	0.294	9.9	0.299	11.2	0.303	12.6	0.306	13.9	0.309	15.5
	12 in Hg	0.217	9.0	0.238	11.6	0.255	14.4	0.266	17.1	0.274	18.4	0.282	21.1	0.287	25.1	0.291	27.8	0.297	31.1
	16 in Hg	0.198	12.0	0.224	15.5	0.242	19.2	0.255	22.7	0.265	26.3	0.273	30.0	0.279	33.5	0.285	37.0	0.290	41.4

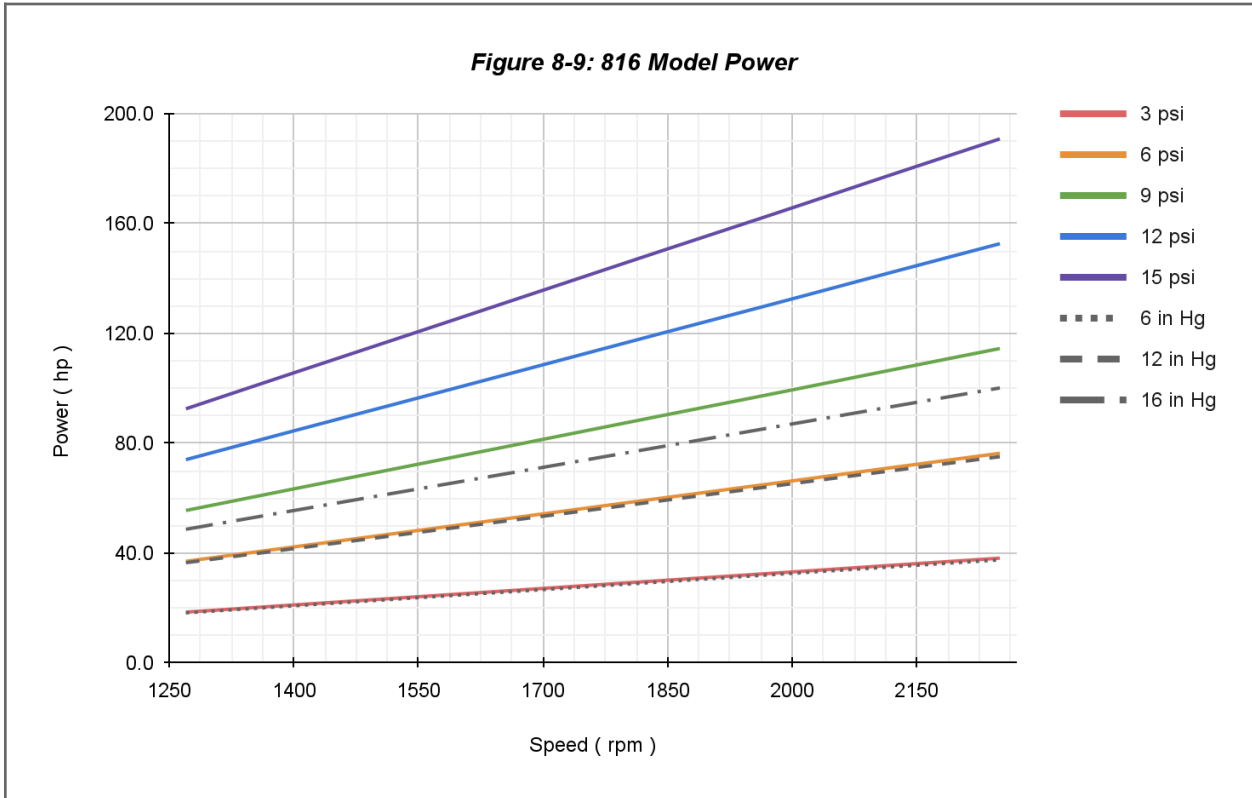
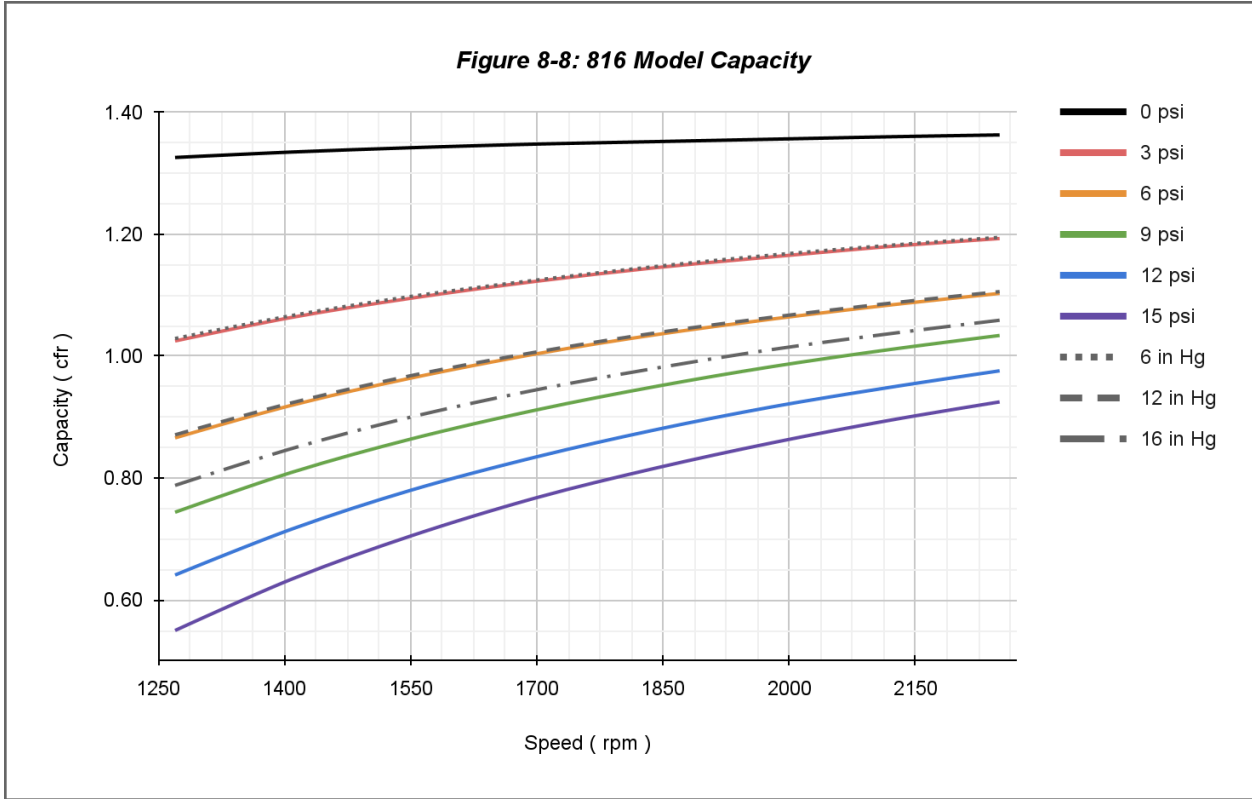
Model	Pressure	Speed (rpm)																	
		1270		1550		1840		2120		2400		2690		2970		3250		3600	
		CFR	HP	CFR	HP	CFR	HP	CFR	HP	CFR	HP	CFR	HP	CFR	HP	CFR	HP	CFR	HP
614	3 psi	0.496	9.0	0.528	11.6	0.550	14.4	0.566	17.1	0.579	19.8	0.588	22.5	0.596	25.2				
	6 psi	0.424	17.9	0.468	23.3	0.500	28.8	0.523	34.1	0.540	39.5	0.554	45.0	0.565	50.3				
	9 psi	0.368	26.9	0.423	34.9	0.462	43.2	0.490	51.2	0.511	59.3	0.528	67.5	0.542	75.5				
	12 psi	0.321	35.8	0.385	46.6	0.430	57.6	0.462	68.3	0.486	79.0	0.506	90.0	0.522	100.7				
	15 psi	0.280	44.8	0.351	58.2	0.401	72.0	0.437	85.3	0.464	98.8	0.486	112.5	0.504	125.9				
	6 in Hg	0.498	8.8	0.528	11.4	0.550	14.1	0.567	16.8	0.580	19.4	0.588	22.1	0.598	25.1				
	12 in Hg	0.426	17.7	0.470	22.9	0.502	28.3	0.525	33.6	0.541	38.9	0.555	44.2	0.566	50.1				
	16 in Hg	0.388	23.6	0.436	30.5	0.476	37.7	0.503	44.8	0.521	51.9	0.537	58.9	0.551	66.8				

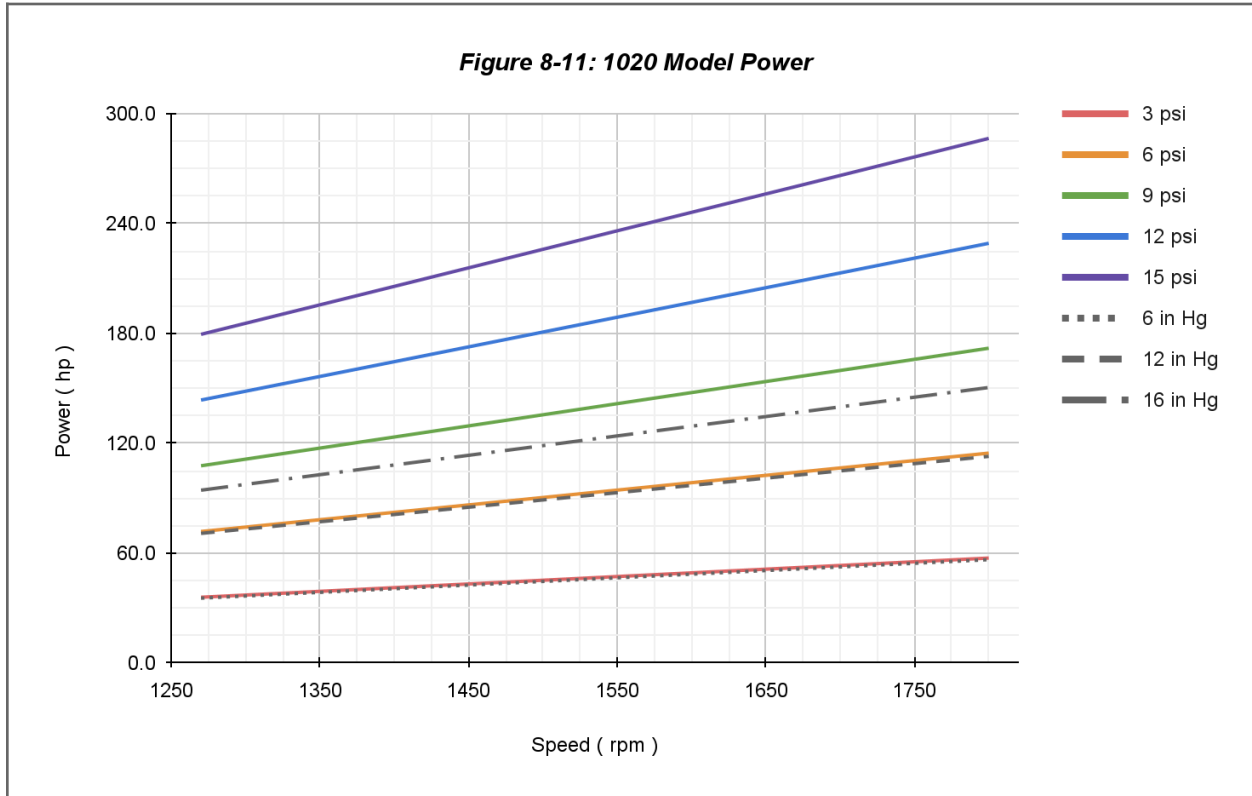
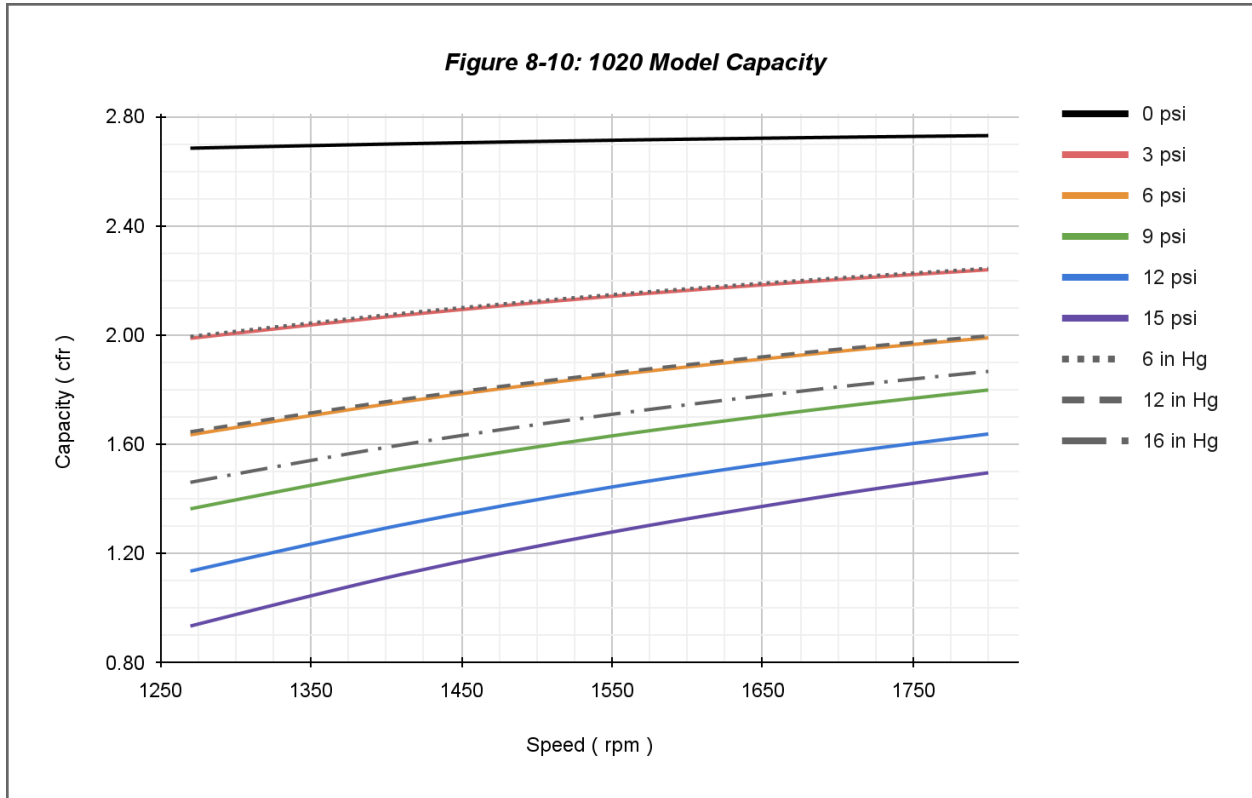
Model	Pressure	Speed (rpm)																	
		1270		1550		1840		2120		2400		2690		2970		3250		3600	
		CFR	HP	CFR	HP	CFR	HP	CFR	HP	CFR	HP	CFR	HP	CFR	HP	CFR	HP	CFR	HP
816	3 psi	1.025	18.5	1.095	24.1	1.145	30.0	1.180	35.6										
	6 psi	0.866	37.0	0.964	48.3	1.035	59.9	1.084	71.1										
	9 psi	0.744	55.5	0.864	72.4	0.950	89.9	1.011	106.7										
	12 psi	0.641	74.0	0.780	96.5	0.879	119.8	0.949	142.3										
	15 psi	0.550	92.6	0.705	120.7	0.816	149.8	0.895	177.9										
	6 in Hg	1.029	18.3	1.098	23.8	1.147	29.5	1.182	35.0										
	12 in Hg	0.871	36.5	0.968	47.5	1.038	59.0	1.087	70.0										
	16 in Hg	0.788	48.7	0.900	63.4	0.980	78.6	1.037	93.3										
1020	3 psi	1.988	35.9	2.142	47.2	2.239	57.3												
	6 psi	1.635	71.8	1.853	94.4	1.990	114.6												
	9 psi	1.364	107.7	1.631	141.6	1.799	171.9												
	12 psi	1.136	143.6	1.444	188.8	1.638	229.2												
	15 psi	0.935	179.5	1.279	236.1	1.496	286.5												
	6 in Hg	1.995	35.4	2.148	46.5	2.244	56.4												
	12 in Hg	1.646	70.8	1.861	93.0	1.997	112.8												
	16 in Hg	1.461	94.4	1.710	124.0	1.867	150.5												









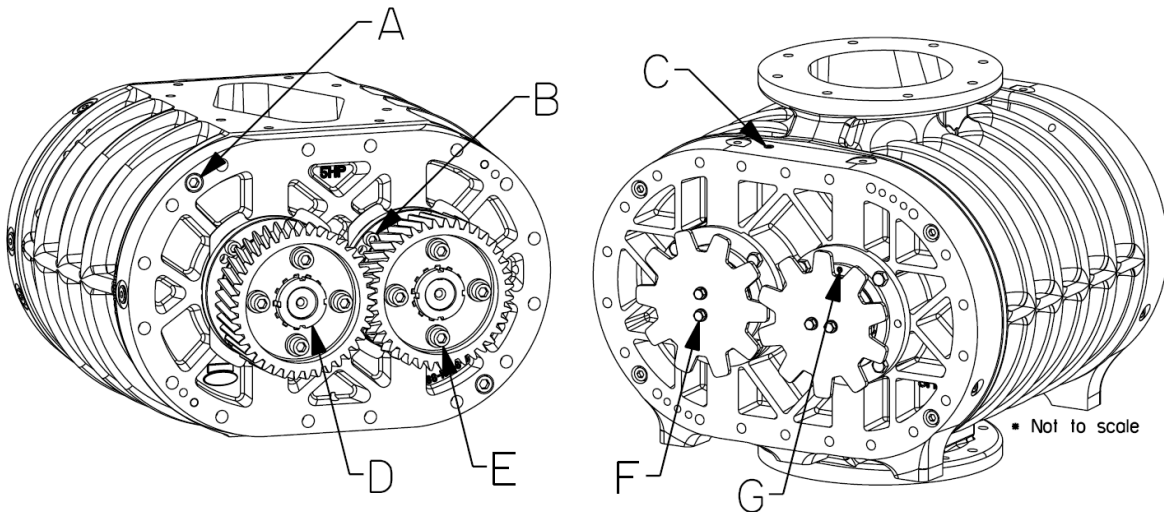


## BOLT TORQUES

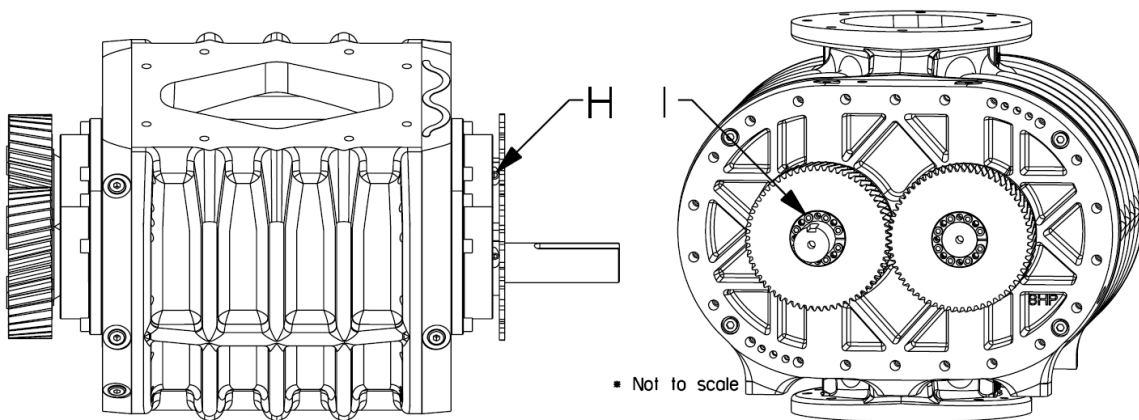
The critical required torque values for the blower fasteners are identified in **Table 8-2**. For any fasteners not specified in **Table 8-2**, refer to **Table 8-3** and **Table 8-4** for imperial and metric bolt torque requirements respectively. Check the tightness of bolts periodically. Replace any damaged or lost hardware with the same strength fastener. Torque values indicated in the following tables are valid for non-greased or non-oiled threads and heads. Unless otherwise specified, do not grease or oil bolts or cap screws. When using locking elements, increase the listed torque values by 5%. Reference **Figure 8-15** and **Figure 8-16** for proper grade identification.

**Table 8-2: Fastener torque specification**

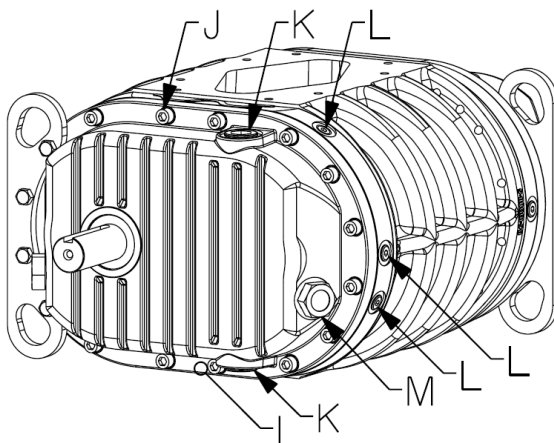
	<b>506</b> lb-ft (Nm)	<b>510</b> lb-ft (Nm)	<b>614</b> lb-ft (Nm)	<b>816</b> lb-ft (Nm)	<b>1020</b> lb-ft (Nm)
<b>Headplate Internal Cap Screw</b> (Fig. 8-14 A)	51 (69.1)	51 (69.1)	51 (69.1)	90 (122.0)	90 (122.0)
<b>Bearing Cartridge Bolt</b> (Fig. 8-14 B)	29 (39.3)	29 (39.3)	51 (69.1)	90 (122.0)	90 (122.0)
<b>Headplate Vent Plug</b> (Fig. 8-14 C)	—	—	—	8 (10.8)	8 (10.8)
<b>Shaft Lock Nut</b> (Fig. 8-14 D)	230 (311.9)	230 (311.9)	347 (470.5)	—	—
<b>Timing Gear Bolt</b> (Fig. 8-14 E)	51 (69.1)	51 (69.1)	119 (161.3)	—	—
<b>Oil Slinger Bolt</b> (Fig. 8-14 F)	—	—	—	44 (59.7)	44 (59.7)
<b>Bearing Cartridge Set Screw</b> (Fig. 8-14 G)	—	—	—	13 (17.6)	13 (17.6)
<b>Oil Slinger Retaining Collar</b> (Fig. 8-15 H)	14 (19.0)	14 (19.0)	16 (21.7)	—	—
<b>Locking Bushing</b> (Fig. 8-15 I)	—	—	—	30 (40.7)	30 (40.7)
<b>Cover Bolt</b> (Fig. 8-16 J)	51 (69.1)	51 (69.1)	51 (69.1)	90 (122.0)	90 (122.0)
<b>Fill / Drain Plug</b> (Fig. 8-16 K)	8 (10.8)	8 (10.8)	8 (10.8)	8 (10.8)	8 (10.8)
<b>Headplate Plugs</b> (Fig. 8-16 L)	8 (10.8)	8 (10.8)	8 (10.8)	8 (10.8)	8 (10.8)
<b>Sight Glass</b> (Fig. 8-16 M)	8 (10.8)	8 (10.8)	8 (10.8)	8 (10.8)	8 (10.8)



**Figure 8-12: Blower fasteners – idle end internal view**



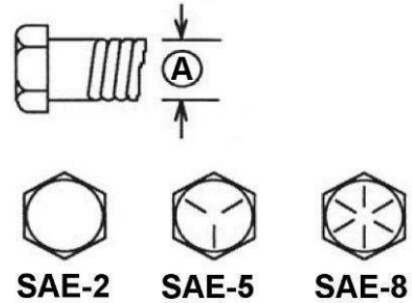
**Figure 8-13: Blower fasteners – drive end internal view**



**Figure 8-14: Blower fasteners – external view**

**Table 8-3: Imperial torque specifications**

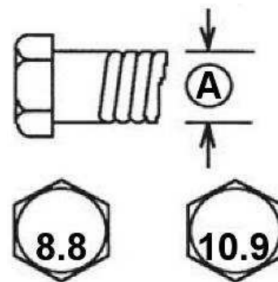
Bolt Diameter "A" [in]	Bolt Torque					
	SAE 2		SAE 5		SAE 8	
	[Nm]	[lb-ft]	[Nm]	[lb-ft]	[Nm]	[lb-ft]
1/4	8	6	12	9	17	12
5/16	13	10	25	19	36	27
3/8	27	20	45	33	63	45
7/16	41	30	72	53	100	75
1/2	61	45	110	80	155	115
9/16	95	60	155	115	220	165
5/8	128	95	215	160	305	220
3/4	225	165	390	290	540	400
7/8	230	170	570	420	880	650
1	345	225	850	630	1320	970



**Figure 8-15: Imperial bolts**

**Table 8-4: Metric torque specifications**

Bolt Diameter "A"	Bolt Torque			
	8.8		10.9	
	[Nm]	[lb-ft]	[Nm]	[lb-ft]
M3	0.5	0.4	1.8	1.3
M4	3	2.2	4.5	3.3
M5	6	4	9	7
M6	10	7	15	11
M8	25	18	35	26
M10	50	37	70	52
M12	90	66	125	92
M14	140	103	200	148
M16	225	166	310	229
M20	435	321	610	450
M24	750	553	1050	774
M30	1495	1103	2100	1550
M36	2600	1917	3675	2710



**Figure 8-16: Metric bolts**

## STANDARDS AND REGULATIONS

Walinga follows the general safety standards specified by the American Society of Agricultural Engineers (ASAE) and the Occupational Safety and Health Administration (OSHA) with consideration of standards outlined by the National Fire Prevention Agency (NFPA), International Organization for Standardization (ISO), Occupational Health and Safety Standards (OH&S), and American National Standards Institute (ANSI). Be aware that there may be additional local or federal laws and regulations that require compliance based on operational location that are the responsibility of the owner and/or operator. For your convenience, the standards referenced in this manual and pertinent to blowers are listed below.

NFPA 652	Standard on the Fundamentals of Combustible Dust
ISO 4254-1	Agricultural Machinery - Safety - Part 1: General Requirements
NFPA 70	National Electric Code



**PAGE INTENTIONALLY LEFT BLANK**



# Warranty

---

AFTERMARKET PARTS AND SERVICE

---

*Walinga Inc. is committed to providing a quality product that will meet or exceed expectations for many years to come. The warranty terms and warranty claim process have been designed to ensure that each warranty claim will be resolved in an orderly, fair and timely manner.*

## THE WARRANTY

Walinga Inc. ("Walinga") warrants that all new pneumatic products sold by Walinga will be free from defects in material and workmanship (the "Walinga Warranty").

## WARRANTY PERIOD

The warranty period for Walinga parts shall expire six (6) months after the date of sale to the original customer; with the exception of parts purchased from a Walinga authorized dealer. In these situations, the warranty period shall expire six (6) months after the date of sale recorded on the dealer's Sales Order to their customer.

Parts which are purchased from Walinga and installed at a Walinga service facility, a Walinga authorized dealer, or a Walinga authorized service facility will qualify for a six (6) month warranty extension; bringing the total warranty period for these items to one (1) year from the date of their installation.

## LIMITATIONS AND EXCLUSIONS OF THE WALINGA WARRANTY

- The Walinga Warranty applies to material and workmanship only.
- With respect to any component parts that are supplied or manufactured by others, the warranty coverage on such component parts will be strictly limited to the warranties of the manufacturers of such component parts.
- The Walinga Warranty shall only be for the benefit of the original purchaser of the aftermarket parts and service.
- A Walinga Warranty may be transferable by the original purchaser to a third party for the balance of the warranty period then remaining, provided that Walinga consents in writing to such a transfer of warranty.
- The Walinga Warranty is conditional upon proper storage, installation, use, maintenance, operation, and compliance with any applicable recommendations of Walinga.

## WARRANTY CLAIM PROCEDURE

Should any difficulties with a unit within its warranty period be encountered, please contact a local Walinga dealer or sales representative, the local Walinga Service Department or Walinga's Warranty Department to submit a warranty claim application.

To speak with a Walinga Warranty Coordinator, contact:

Canada and  
International      1-888-WALINGA (ext 325)  
                             +1-519-824-8520 (ext 325)  
                             warranty.canada@walinga.com

USA                    1-888-WALINGA (ext 325)  
                             warranty.usa@walinga.com

Australia            07-4634-7344  
                             mail@customvac.com.au

## REQUIRED WARRANTY CLAIM INFORMATION

The following information must be provided to Walinga for proper consideration and processing of a warranty application:

- Customer name and contact information, including email if available
- The original Sales Order number, the equipment serial number, and/or the Vehicle Identification Number (VIN), if applicable
- Date of claimed failure
- Details, description and photos (upon request) of the claimed failure and the corrective repairs attempted

## WARRANTY CONDITIONS

- Parts Warranty term begins on the date of purchase by the original purchaser; with the exception of items purchased from a Walinga authorized dealer, in which case the warranty period will begin on the purchase date recorded on the dealer's Sales Order to their customer.
- The buyer is responsible for promptly notifying Walinga of any defects to the parts to the parts or workmanship, and making the equipment available to Walinga or its authorized facility for evaluation or repair.
- Prior to making any repairs or parts replacements, a warranty application and any estimated associated costs must be approved with the issuance of a claim number by an authorized Walinga representative. Undertaking any work prior or part replacement prior to receiving warranty authorization may result in a partial or complete loss of warranty coverage.
- Walinga is not responsible for the cost of labor associated with part removal or installation performed by the customer or service providers other than Authorized Dealers and Service Centers or the costs of parts and labor associated with the repair or replacement of parts resulting from the use of non-Walinga approved parts and/or parts that do not meet Walinga specifications.
- At Walinga's request, parts in question must be returned to the nearest Walinga service facility for evaluation. In such situations, a Returned Goods Authorization (RGA) number will be provided to the customer. The returning shipment must be clearly labeled with the assigned RGA number and include a copy of the RGA form. Unless otherwise arranged, these parts are to be returned to Walinga within thirty (30) days to ensure timely processing of the warranty claim. Failure to return such parts may result in partial or complete loss of warranty coverage.
- Replacement parts provided under warranty are covered for the remainder of the original purchased parts or service warranty period.
- Walinga reserves the right to use new, remanufactured or refurbished components when performing warranty repairs and replacements.
- Walinga is entitled to a reasonable amount of time and a reasonable number of attempts to assess the claim, diagnose the problem, and perform any necessary repairs.
- The warranty offered on used or refurbished parts is limited to that specified on the Sales Order. Where a warranty period has not been stipulated on the purchase contract, such equipment is considered to be sold "as is, where is".

## WARRANTY CLAIM REJECTION

Without limitation, Walinga reserves the right to reject a warranty claim for any one or more of the following reasons:

- The warranty claim information provided is insufficient.
- The product evaluation does not substantiate the claim.
- The unit has been operated above and beyond its capacity or not maintained or serviced properly, resulting in damages incurred to major components.
- It is apparent that the operator's manuals have not been followed.

## NOT COVERED UNDER WARRANTY

Without limitation, the Walinga Warranty does not cover:

- Damage or deterioration due to lack of reasonable care or maintenance.
- Damage caused or affected by unapproved modifications to the equipment.
- Damage caused by negligence or misuse of the equipment.
- Damage caused by improper repair of equipment or incorrect installation of components.
- Damage caused by using the equipment for purposes for which it was not designed or intended.

Walinga's liability under this warranty, whether in contract or tort, is limited to the repair, replacement or adjustment of defective materials and workmanship. In no event will Walinga be responsible for any direct, indirect, loss of time, incidental or consequential expenses including, but not limited to equipment rental expenses, towing, downtime, inconvenience, or any losses resulting from the inability to use the equipment. Further, Walinga shall not be liable for any damages or inconvenience caused by any delay in the supply of any equipment or component parts thereof.

The selling dealer/salesperson makes no warranty of its own and has no authority to make any representation or promise on behalf of Walinga, or to modify the terms or limitations of the Walinga Warranty in any way.

Punitive, exemplary or multiple damages may not be recovered unless applicable law prohibits their disclaimer.

Warranty related claims may not be brought forward as a class representative, a private attorney general, a member of a class of claimants or in any other representative capacity.

The Walinga Warranty and all questions regarding its enforceability and interpretation are governed by the law of the country, state or province in which the Walinga equipment was purchased. The laws of some jurisdictions limit or do not allow the disclaimer of consequential damages. If the laws of such a jurisdiction apply to any claim against Walinga, the limitations and disclaimers contained here shall be to the greatest extent permitted by law.



# Accessories and Attachments

---

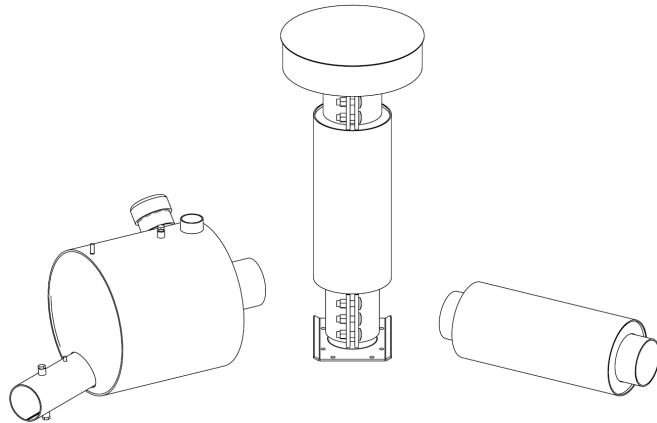
BLOWER MODELS

---

A wide variety of accessories are available for your blower model to improve your operational experience. Below are some of the available accessories and a general description of their function. Please contact your Walinga dealer or representative for accessories compatible with your specific blower, availability and ordering, or if you have any questions.

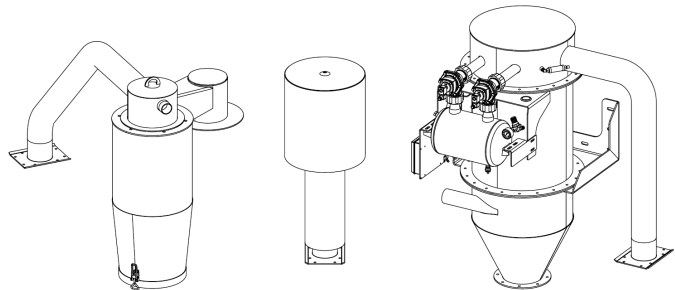
## MUFFLERS

To reduce level and alter the pitch of the noise generated by the blower, a variety of mufflers are available for installation on the inlet or outlet side.



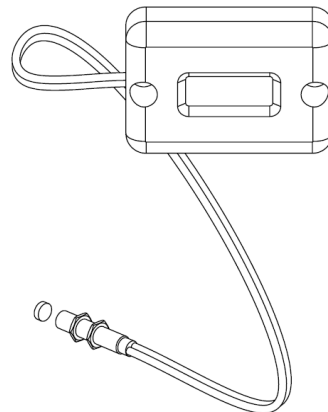
## INLET FILTERS

To extend the life of the blower, an inlet filter, contaminant reducing assembly such as a secondary air-material separator, or primary air-material separator with an air purge system may be available.



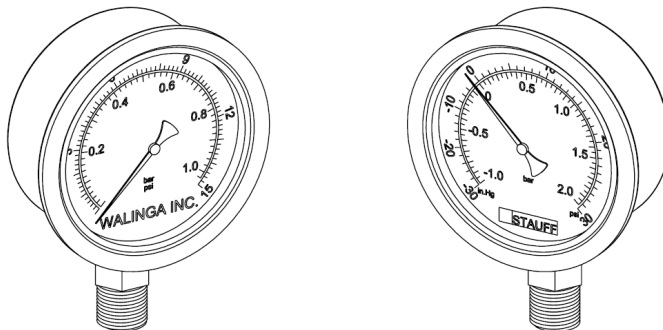
## TACHOMETER

To keep an accurate log of the operational hours and to measure the instantaneous rotational speed of the input shaft of the blower, a tachometer and hour meter device is available for installation.



**PRESSURE GAUGES**

To allow better monitoring of the performance and to provide potential issue diagnostic information, gauges are available to measure both the outlet pressure and inlet vacuum pressure as applicable.



**FOOD GRADE LUBRICANTS**

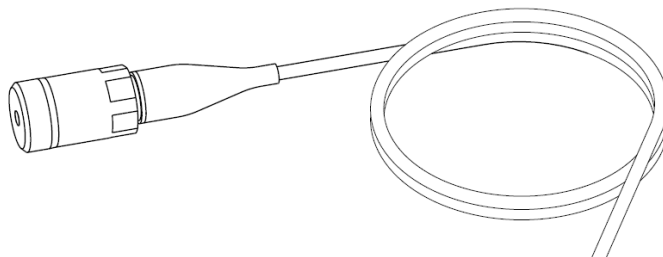
To accommodate the requirements and restrictions of specialized industries, a replacement lubricating oil is available that meets the operational requirements of a Walinga blower and the restrictions of food grade industries.



Nonfood Compounds  
Program Listed H1

**BEARING SENSORS**

To provide more accurate monitoring of the temperature and vibration of the impeller shaft bearings, a combined temperature and vibration sensor is available for installation.





**PAGE INTENTIONALLY LEFT BLANK**



# Parts List

---

BLOWER 614 MODEL

---

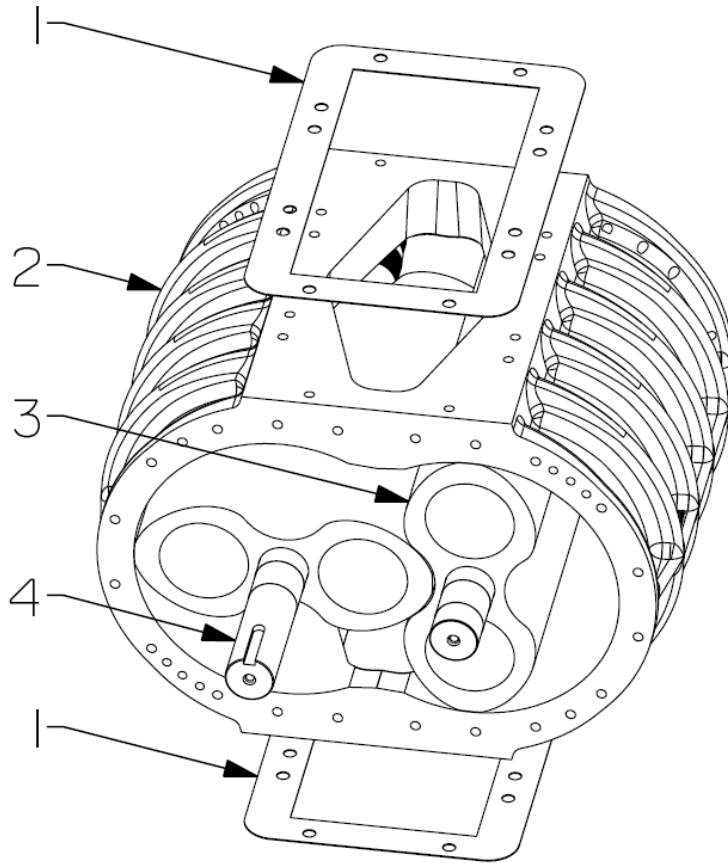
**MODEL REFERENCES**

Refer to **Section 3: Machine Configuration** for detailed information regarding the naming and short forms of various key features of the blower. Refer to **Table 11-1** for the top level assembly numbers of each blower and their respective key features. The reference codes for each model assigned in **Table 11-1** will be used as the top-level model identification for the remainder of this section. The last five to six digits of the blower's serial number may be used to assist with proper model identification as it will correspond to one assembly number listed in the table below.

**Table 11-1: Top-level model assemblies**

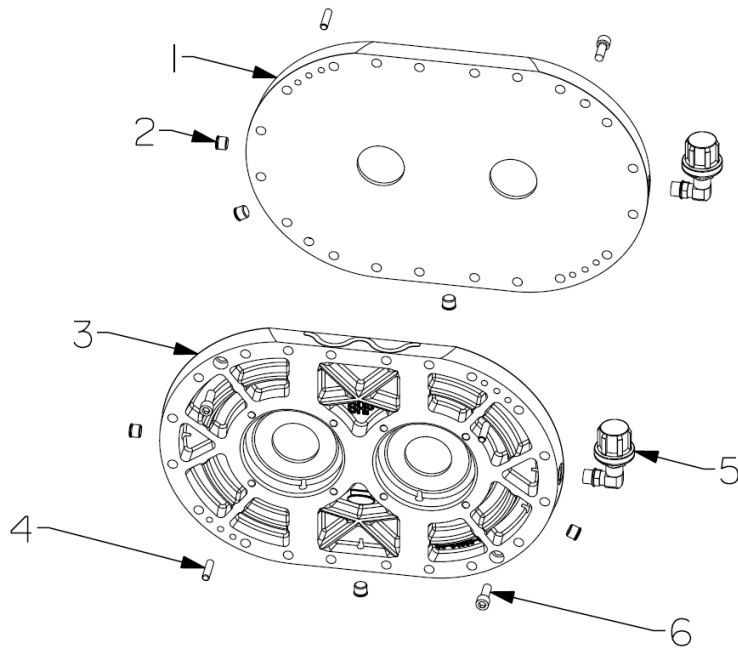
Reference Code	Assembly Number	Features													
		Body				Drive					Impeller				
		HC	VM	MM	S	SL	Position		Rotation		GH Ratio	RT	CAP	T	CTR
LHD	RHD						CCW	CW							
614-A	50-69733-5	×				2.25"	×		×						
614-B	50-77344-5	×				2.25"	×		×			×			
614-C	50-126549-5	×				2.25"	×		×				×		
614-D	50-88030-5	×				2.25"		×		×					
614-E	50-41638-5	×				4.00"	×		×						
614-F	50-56178-5	×				4.00"	×		×					×	
614-G	50-07777-5	×				7.50"	×		×						
614-H	50-45715-5	×				7.50"	×		×			×			
614-I	50-82621-6	×				7.50"	×		×					×	
614-J	50-124810-5	×				7.50"	×			×					
614-K	50-39325-5	×				7.50"		×		×					
614-L	50-70056-5	×		×		7.50"	×		×				×		
614-M	50-102856-5	×		×		7.50"		×		×			×		

**CASING AND IMPELLER COMPONENTS**



Model		Description	Part Number
A, B, C, D, E, F, G, H, I, J, K, L, M	1	MOUNTING GASKET, 614	96-09117-6
A, B, C, D, E, F, G, H, I, J, K	2	CASING, 614, HC	50-09194-4
L, M		CASING, 614, HC, MM	50-70057-4
A, D, E, F, G, I, J, K	3	DRIVEN IMPELLER, 614, 21 1/2"	50-37875-5
B, H		DRIVEN IMPELLER, RT, 614, 21 1/2"	50-66502-5
C, L, M		DRIVEN IMPELLER, CAP, 614, 21 1/2"	50-139577-5
A, D	4	DRIVING IMPELLER, 614, 24 3/4"	50-69793-5
B		DRIVING IMPELLER, RT, 614, 24 3/4"	50-77345-5
C		DRIVING IMPELLER, CAP, 614, 24 3/4"	50-139560-5
E, F		DRIVING IMPELLER, 614, 26 1/2"	50-92574-5
G, I, K		DRIVING IMPELLER, 614, 30"	50-37874-5
H		DRIVING IMPELLER, RT, 614, 30"	50-66520-5
J		DRIVING IMPELLER, FULL KEY, 614, 30"	50-124809-5
L, M		DRIVING IMPELLER, CAP, 614, 30"	50-158211-5

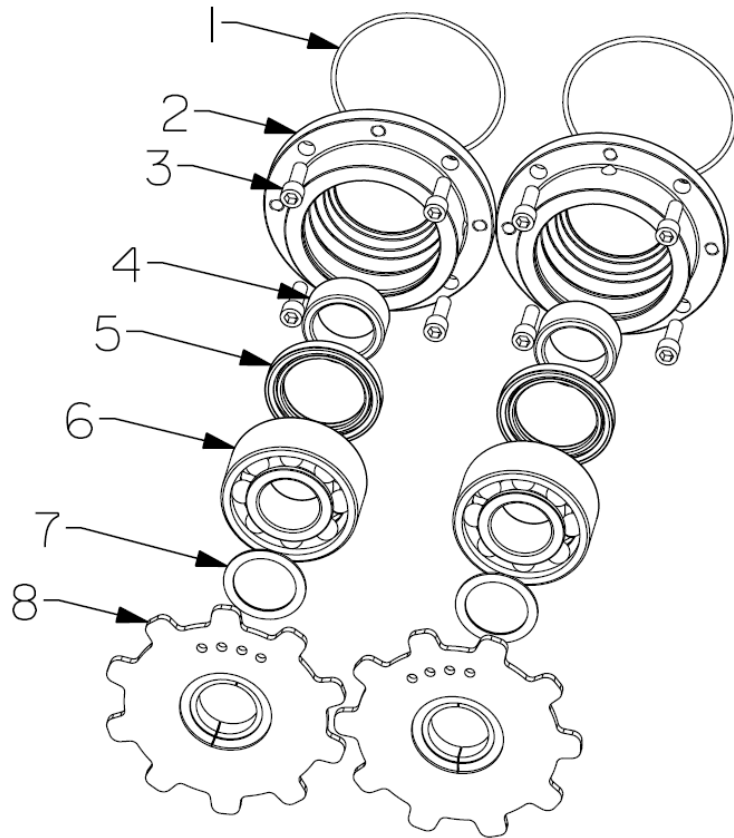
**HEADPLATE COMPONENTS**



Model		Description	Part Number
A, B, C, D, E, F, G, H, I, J, K, L, M	1	HEADPLATE, IDLE, 614	50-09193-5
A, B, C, D, E, F, G, H, I, J, K	2	PLUG, 6MB, W/ MAGNET	58-80675-6
L, M		PLUG, 6MB HEX, W/ MAGNET	58-158498-6
A, B, C, D, E, F, G, H, I, J, K, L, M	3	HEADPLATE, DRIVE, 614	50-117188-5
	4	DOWEL PIN, 5/16 x 1 1/4	94-00170-6
	5	BREATHER CAP, 1/4 NPT, 10 MICRON OR BREATHER CAP, 3/4 NPT, 40 MICRON	39-14001-6* OR 39-82486-6*
		6	CAP SCREW, 3/8-16-1, SOCKET

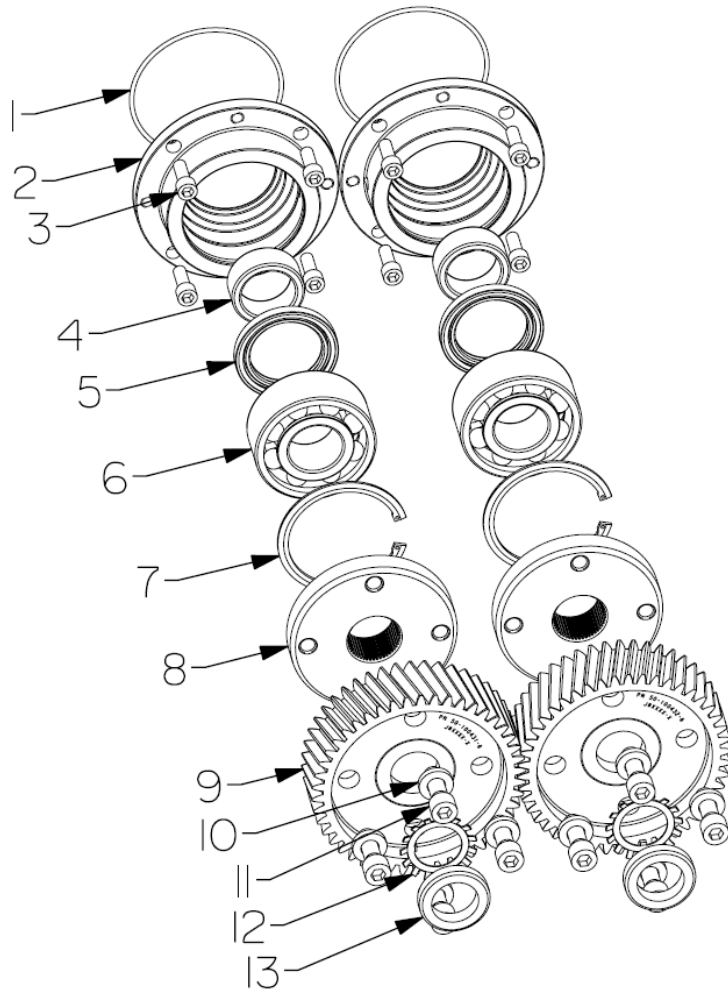
\* Adapters, elbows, or fittings may be required for mounting.

**DRIVE END COMPONENTS**



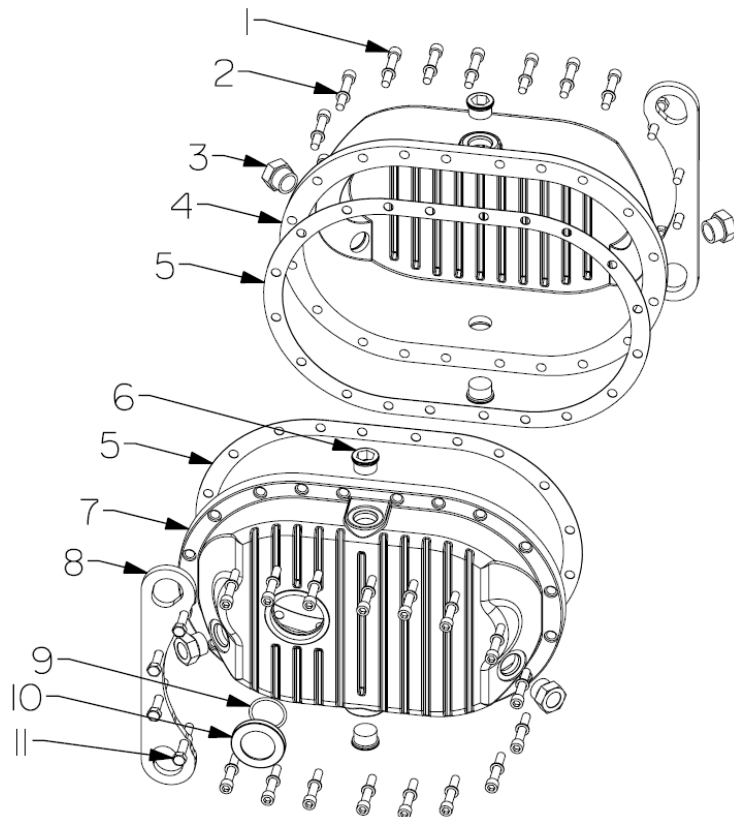
Model	Description	Part Number	
A, B, C, D, E, F, G, H, I, J, K, L, M	1	O-RING, 2-244, V75	96-04981-6
	2	BEARING CARTRIDGE, 614	50-49663-4
	3	CAP SCREW, 3/8-16-1, SOCKET	94-08494-6
	4	SHAFT SLEEVE, 614	50-07221-4
	5	SHAFT SEAL, CR 21167	96-82432-6
	6	BALL BEARING, 3308, C3	96-19942-6
	7	THRUST WASHER, 1 5/8 x 2 1/8 x 1/16	94-81591-6
	8	OIL SLINGER, 614	50-96071-5

**IDLE END COMPONENTS**



Model	Description	Part Number
A, B, C, D, E, F, G, H, I, J, K, L, M	1 O-RING, 2-244, V75	96-04981-6
	2 BEARING CARTRIDGE, 614	50-49663-4
	3 CAP SCREW, 3/8-16-1, SOCKET	94-08494-6
	4 SHAFT SLEEVE, 614	50-07221-4
	5 SHAFT SEAL, CR 21167	96-82432-6
	6 BALL BEARING, 3308, C3	96-19942-6
	7 RETAINING RING, 5002-354	50-07212-6
	8 TIMING HUB, 614	50-07200-4
A, B, C, D, E, F, G, H, I, J, K	9 TIMING GEAR SET, AGMA 8, 614, 1 3/4"	50-07198-6
L, M		50-106981-6
A, B, C, D, E, F, G, H, I, J, K, L, M	10 TIMING WASHER, 17/32 x 1 x 3/16	94-07267-6
	11 CAP SCREW, 1/2-13-1 1/2, SOCKET	94-07213-6
	12 LOCK WASHER, W-07	94-07207-6
	13 LOCK NUT, N-07	94-07206-6

**COVER COMPONENTS**



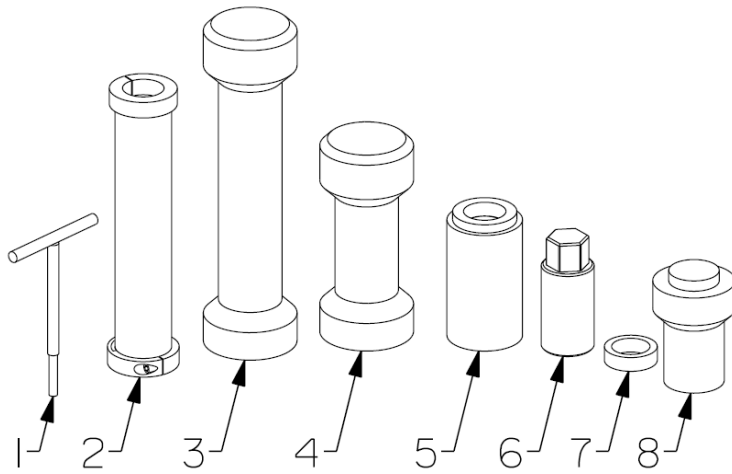
Model	Description	Part Number
A, B, C, D, E, F, G, H, I, J, K, L, M	1 CAP SCREW, 3/8-16-2 1/4, SOCKET	94-14069-6
	2 WASHER, .625 OD x .404 ID x .056	94-07268-6
	3 SIGHT GLASS, 12MB	58-19690-6
	4 COVER, IDLE, 614	50-143756-4
	5 COVER GASKET, 614	96-18679-6
A, B, C, D, E, F, G, H, I, J, K	6 PLUG, 12MB	58-19689-6
L, M	6 PLUG, 12 MB HEX, W/ MAGNET	50-158497-6
A, B, C, E, F, G, H, I, J, L	7 COVER, DRIVE, 614	50-143758-4
D, K, M	7 COVER, DRIVE, RHD, 614	50-155357-4
A, B, C, D, E, F, G, H, I, J, K, L, M	8 LIFTING HOOK, 506	50-42143-4
	9 O-RING, 2-222, N70	96-04824-6
	10 SHAFT SEAL, CR 15656	96-07197-6
	11 BOLT, 3/8-16-2 3/4, GR8	94-05323-6

MISCELLANEOUS

Description	Part Number
SUPER DUTY BLOWER OIL, 4L	98-13813-5
FOOD GRADE GEAR FLUID, PURITY, 20L	98-133710-6
COPPER PASTE, COPASLIP, 3473	98-04326-6
INLET/OUTLET DEBRIS COVER, 614	50-38099-4
HEADPLATE GASKET PAPER, TEFLON, 0.002"	96-19816-6
HEADPLATE GASKET PAPER, TEFLON, 0.004"	96-14720-6
HEADPLATE GASKET PAPER, OIL, 0.006"	96-07281-6
HEADPLATE GASKET PAPER, OIL, 0.010"	96-07282-6
BEARING CARTRIDGE SHIM, 614, 0.002"	50-07208-6
BEARING CARTRIDGE SHIM, 614, 0.003"	50-07209-6
BEARING CARTRIDGE SHIM, 614, 0.004"	50-93921-6
BEARING CARTRIDGE SHIM, 614, 0.006"	50-93922-6
BEARING CARTRIDGE SHIM, 614, 0.010"	50-07210-6
BEARING CARTRIDGE SHIM, 614, 0.015"	50-07211-6
614 BLOWER REPAIR KIT, 2.25" SHAFT	50-111273-5*
614 BLOWER REPAIR KIT, 4" & 7.5" SHAFT	50-111274-5*

\* The repair kit contains: shaft lock nut (x2), shaft lock washer (x2), timing washer (x8), ball bearing (x4), bearing cartridge shaft seal (x4), shaft seal, (x1), bearing cartridge O-ring (x4), oil cover gasket (x2), Walinga Super Duty Blower Oil (4 L x1).

**ASSEMBLY TOOLS**



Description		Part Number
1	HEADPLATE ALIGNMENT TOOL, 614	32-130116-5
2	SHAFT ROTATION EXTENSION, 614	32-130117-5
3	BEARING DRIVER, LONG, 614	32-130126-4
4	BEARING DRIVER, SHORT, 614	32-130127-4
5	INPUT SHAFT SEAL DRIVER, 614	32-130128-4
6	IMPELLER LOCKING COLLAR, 614	32-130130-4
7	LOCKING COLLAR SPACER, 614	32-130131-4
8	BEARING CARTRIDGE SEAL DRIVER, 614	32-130132-4

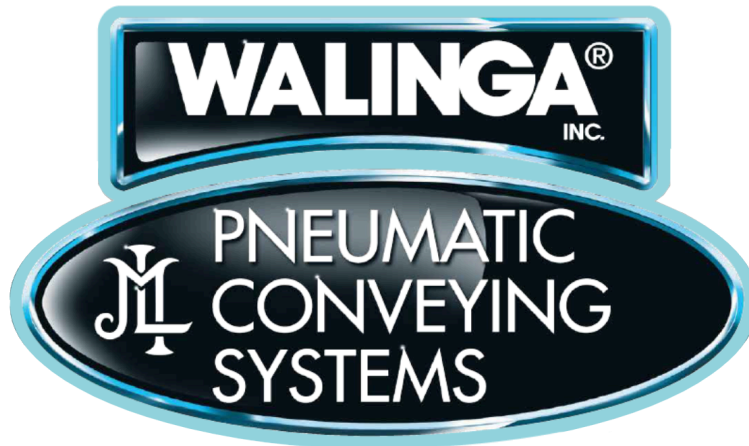


**PAGE INTENTIONALLY LEFT BLANK**



**PAGE INTENTIONALLY LEFT BLANK**

---



**WALINGA**<sup>®</sup>  
INC.

**CORPORATE HEAD OFFICE:**

5656 Highway 6N RR#5  
Guelph, Ontario, N1H 6J2  
*PHONE* (519) 824-8520  
*FAX* (519) 824-5651  
[www.walinga.com](http://www.walinga.com)

**FACTORY DISTRIBUTION AND SERVICE CENTERS:**

938 Glengarry Crescent  
Fergus, ON, Canada, N1M 2W7  
*PHONE* (519) 787-8227  
*FAX* (519) 787-8210

70 3rd Avenue N.E. Box 1790  
Carman, MB, Canada, R0G 0J0  
*PHONE* (204) 745-2951  
*FAX* (204) 745-6309

6116 46 St.  
Barrhead, AB, Canada, T0G 0G0  
*PHONE* (780) 572-6082

1190 Electric Avenue  
Wayland, MI, USA, 49348  
*PHONE* (800) 466-1197  
*FAX* (616) 877-3474

579 4th St. NW  
Sioux Center, IA, USA, 51250  
*PHONE* (800) 845-5589  
*FAX* (712) 722-1128

24 Molloy St.  
Toowoomba, Qld, Australia, 4350  
*PHONE* 07-4636-7344  
*EMAIL* [mail@customvac.com.au](mailto:mail@customvac.com.au)