

OPERATOR'S MANUAL

Airlock 1314

English

WALINGA®
TOUGH TO BEAT IN THE LONG RUN

00-156415-0 A
2025-01-13

TO OUR VALUED CUSTOMERS:

The Walinga network of distribution centers and authorized dealers are dedicated to providing worldwide coverage of original parts and accessories for Walinga Pneumatic Conveying Systems. Our parts reflect Walinga's continued commitment to provide our customers with the highest quality parts and service.

For your convenience, should you require any information related to technical support, warranty, service, parts, or sales, please contact one of the following Walinga personnel:

TECHNICAL SUPPORT

1-833-233-8227

pcs.techsupport@walinga.com

WALINGA WARRANTY COORDINATORS

Canada and International
USA
Australia

1-888-WALINGA (ext 258)
1-800-466-1197 (ext 8)
07-4634-7344

warranty.canada@walinga.com
warranty.usa@walinga.com
mail@customvac.com.au

SERVICE

Guelph, ON, Canada
Carman, MB, Canada
Barrhead, AB, Canada
Wayland, MI, USA
Sioux Center, IA, USA
Toowoomba, QLD, Australia

1-888-WALINGA (ext 228)
1-800-668-6344 (ext 418)
1-780-572-6082 (ext 1001)
1-800-466-1197 (ext 508)
1-800-845-5589 (ext 804)
07-4634-7344

guelph.service@walinga.com
carman.service@walinga.com
todd.swaving@walinga.com
wayland.service@walinga.com
siouxcenter.service@walinga.com
mail@customvac.com.au

ORIGINAL PARTS SALES

Eastern Canada and International
Western Canada
Eastern USA
Western USA
Australia

1-888-WALINGA (ext 224)
1-800-668-6344 (ext 421)
1-800-466-1197 (ext 507)
1-800-845-5589 (ext 802)
07-4634-7344

parts.canada@walinga.com
parts.carmen@walinga.com
parts.usa@walinga.com
parts.siouxcenter@walinga.com
parts.australia@walinga.com

SALES MANAGER

Tim Linde

1-519-787-8227 (ext 109)

tim.linde@walinga.com

CORPORATE HEAD OFFICE

5656 Highway 6N
RR#5, Guelph, Ontario, N1H 6J2
Tel: 888-925-4642 Fax: 519-824-5651
www.walinga.com

FACTORY DISTRIBUTION AND SERVICE CENTERS

938 Glengarry Crescent, Fergus
Ontario, Canada N1M 2W7
Tel: 519-787-8227 Fax: 519-787-8210

1190 Electric Avenue, Wayland
Michigan, USA 49348
Tel: 800-466-1197 Fax: 616-877-3474

70 3rd Ave. NE Box 1790, Carmen
Manitoba, Canada R0G 0J0
Tel: 204-745-2951 Fax: 204-745-6309

579 4th St. NW, Sioux Center
Iowa, USA 51250
Tel: 800-845-5589 Fax: 712-722-1128

6116 46 St., Bloomsbury
Alberta, Canada T0G 0J0
Tel: 780-572-6082

24 Molloy St., Toowoomba
Queensland, Australia 4350
Tel: 07-4634-7344 Email: mail@customvac.com.au

Table of Contents

Contact Information [00-156416-0] - - - - -	<i>i</i>
Table of Contents [00-156416-0] - - - - -	<i>ii</i>
Literature Information [00-156416-0] - - - - -	<i>v</i>
Identification of Machine [00-156416-0] - - - - -	1-1
<i>Serial Numbers</i> - - - - -	1-2
Introduction [00-144472-0] - - - - -	2-1
<i>Statement of Importance</i> - - - - -	2-2
<i>Intended Use</i> - - - - -	2-2
<i>Directional References</i> - - - - -	2-3
<i>Airlocks in Pneumatic Conveying Systems</i> - - - - -	2-3
Machine Configuration [00-144473-0] - - - - -	3-1
<i>Model Sizes</i> - - - - -	3-2
<i>Model Variations</i> - - - - -	3-4
Safety [00-144474-0] - - - - -	4-1
<i>Safety Alert Symbol</i> - - - - -	4-2
<i>Signal Words</i> - - - - -	4-2
<i>General Safety</i> - - - - -	4-3
<i>Installation Safety</i> - - - - -	4-4
<i>Storage Safety</i> - - - - -	4-5
<i>Pre-Operation Safety</i> - - - - -	4-5
<i>Operational Safety</i> - - - - -	4-6
<i>Maintenance Safety</i> - - - - -	4-6
<i>Machine Safety Signs</i> - - - - -	4-7
<i>Safety Training Sign-Off Form</i> - - - - -	4-11

Machine Life-Cycle Procedures [00-144475-0] - - - - -	5-1
<i>Reception, Assembly and Initial Set-Up</i> - - - - -	5-2
<i>Storage</i> - - - - -	5-5
<i>End of Life</i> - - - - -	5-6
Operation [00-144476-0] - - - - -	6-1
<i>Machine Features and Components</i> - - - - -	6-2
<i>Controls and Displays</i> - - - - -	6-3
<i>Operation</i> - - - - -	6-3
<i>Pre-Operation Machine Preparation</i> - - - - -	6-3
<i>Operation of the Machine</i> - - - - -	6-4
<i>Stopping the Machine</i> - - - - -	6-5
<i>Operating Tips and Hints</i> - - - - -	6-6
<i>Troubleshooting</i> - - - - -	6-7
Maintenance and Adjustments [00-144477-0] - - - - -	7-1
<i>Maintenance Schedule</i> - - - - -	7-2
<i>Maintenance Safety</i> - - - - -	7-3
<i>Maintenance Procedures</i> - - - - -	7-3
<i>Maintenance Materials</i> - - - - -	7-34
<i>Adjustments</i> - - - - -	7-34
Specifications [00-144478-0] - - - - -	8-1
<i>Technical Data</i> - - - - -	8-2
<i>Bolt Torques</i> - - - - -	8-4
<i>Standards and Regulations</i> - - - - -	8-9
Warranty [00-145861-0] - - - - -	9-1
<i>The Warranty</i> - - - - -	9-2
<i>Warranty Period</i> - - - - -	9-2
<i>Limitations and Exclusions of the Walinga Warranty</i> - - - - -	9-2
<i>Warranty Claim Procedure</i> - - - - -	9-2

<i>Required Warranty Claim Information</i> - - - - -	9-3
<i>Warranty Conditions</i> - - - - -	9-3
<i>Warranty Claim Rejection</i> - - - - -	9-4
<i>Not Covered Under Warranty</i> - - - - -	9-4
Accessories and Attachments [00-144480-0] - - - - -	10-1
Parts List [00-145719-0] - - - - -	11-1
<i>Model References</i> - - - - -	11-2
<i>Body Components</i> - - - - -	11-4
<i>Rotor Components</i> - - - - -	11-8
<i>Miscellaneous Components</i> - - - - -	11-11

This manual contains important information regarding the safety, operation and maintenance of your Walinga airlock.

Some illustrations and diagrams may show safety shields, guards, or covers removed for clarity. **DO NOT** operate the machine without these guards in place.

Identification of Machine

The identification of machine section outlines the applicable models included in this manual. It identifies the location of the machine serial number and serialized components and provides space for recording these numbers.

Introduction

The introduction section outlines the importance of this document and provides details for the interpretation and understanding of information presented in this manual.

Configuration

The configuration section gives an overview of the various configurations available for the specified model and identification between the different configurations.

Safety

The safety section lists important safety precautions and procedures as well as providing the meaning, location and visual representation of all safety signs and labels on the machine. Read and understand all precautions before operating, maintaining or transporting the machine.

Machine Life-Cycle Procedures

The machine life-cycle procedures section provides information on the reception, assembly and initial set-up, transportation, storage, and end of life procedures.

Operation

The operation section gives general information on the operating principles including starting, operating functions, and stopping the machine, as well as clearing any blockages. This section also provides troubleshooting information for fault diagnosis and solutions to issues that may be encountered.

Maintenance and Adjustments

The maintenance and adjustments section provides the recommended maintenance schedule and task instructions for both calendar and operation hour intervals, maintenance should be performed at the first occurrence of these two intervals.

Specifications

The specifications section details technical data of the particular model to achieve a high standard of operational performance and outlines relevant standards and regulations.

Warranty

The warranty section outlines the terms and limitations of the warranty coverage.

Accessories and Attachments

The accessories and attachments section lists available attachments for the machine.

Parts List

The parts list section provides information for the identification of replacement assemblies, subassemblies and parts.



Identification of Machine

AIRLOCK MODELS

SERIAL NUMBERS

Be prepared to provide the serial number of the airlock to your Walinga dealer or representative when ordering parts or requesting service or other information. For easy reference, record the required serial number as follows:

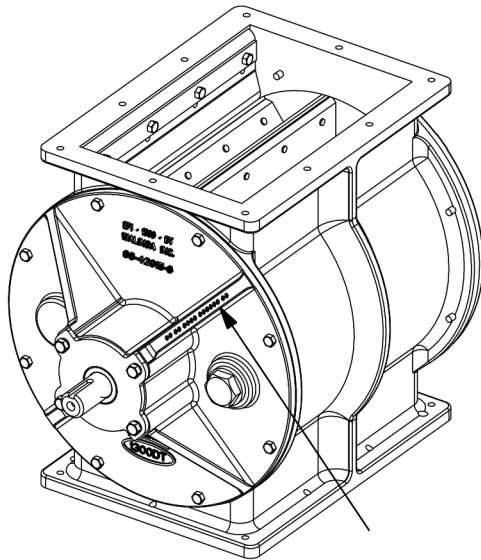

Airlock Serial Number

Located on the rib of the front end plate of the airlock.





Introduction

AIRLOCK MODELS

STATEMENT OF IMPORTANCE

Congratulations on your choice of a Walinga airlock to complement your operation. This equipment has been designed, engineered and manufactured to meet the needs of the discriminating buyer for the efficient moving of bulk commodities.

Your safety and the performance of your airlock are Walinga's top priorities. This operator's manual has been created for the express purpose of keeping you safe and providing education for the efficient use of your airlock.

Safe, efficient and trouble-free operation of your airlock requires that you and any individuals operating or maintaining the machine, read and understand all sections of this operator's manual. An operator who has not familiarized themselves with the contents of this manual constitutes an untrained operator. Untrained operators are not qualified to operate the machine.

Keep this manual available for frequent reference and for provision to new operators or owners.

Your machine's appearance or structural design may differ from illustrations shown in the manual. Continuous design improvements for optimized field performance are on-going and may have been made to your machine since the publication of the manual. Specifications, descriptions and all other information in the manual are subject to change and/or correction without notice. Contact your local dealer or Walinga representative for the most current revision of your machine's manual or if you have any questions.

INTENDED USE

The Walinga airlock has been designed for use in agricultural or similar operations. Use of the machine in any other manner is considered as contrary to the intended use. Compliance with and strict adherence to the methods of operation, maintenance, and repair, as specified by Walinga in this manual, also constitute essential elements of the intended use.

The airlock must be operated, maintained and serviced only by persons who are familiar with its particular characteristics and have been acquainted with the relevant safety procedures in this manual. Any individual who has not familiarized themselves with the content of this manual is considered untrained. Untrained persons are considered unqualified to operate, maintain or service an airlock. It is the responsibility of the owner and/or operator to train new operators and ensure they have read and understood this manual.

Accident prevention regulations, all other generally recognized regulations on safety and occupational health and safety, and all road traffic regulations must be observed at all times.

Any unauthorized modifications carried out to the airlock may relieve Walinga of liability for any resulting damage or injury and is considered contrary to the intended use.

DIRECTIONAL REFERENCES

To avoid confusion, the following directions will be used as a standard throughout the manual:

TOP	The inlet side of the airlock
BOTTOM	The outlet side of the airlock
FRONT	The driven end plate of the airlock
REAR	The non-driven end plate of the airlock
LEFT	The left-hand side as viewed from the FRONT of the airlock
RIGHT	The right-hand side as viewed from the FRONT of the airlock
CCW	The standard counter-clockwise rotational direction of the rotor

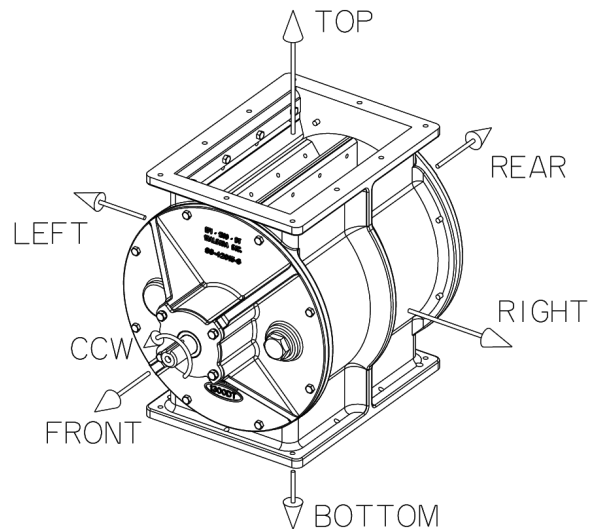

Figure 2-1: Directional references

AIRLOCKS IN PNEUMATIC CONVEYING SYSTEMS

Pneumatic conveying systems use air to move materials, Walinga's airlocks are designed for conveying common agricultural materials, such as cereal grains. The efficient operation depends on many factors including air flows, line sizes, source power, operating methods, and suction and discharge line arrangements, among others. Airlocks are used in a variety of Walinga systems such as in Engineered Transportation Equipment in discharge and transfer systems, as well as in Agri-Vacs, Central-Vacs, Ultra-Vacs, Ultra-Veyors, Silo-Fillers, and Barge Unloaders.

A simplified representation of the function of an airlock in a pneumatic conveying system can be seen in **Figure 2-2** through **Figure 2-4**, showing both the drop-thru and blow-thru models. An airlock acts as a seal between two sides of a pneumatic conveying system with a pressure differential.

Product will enter the airlock from the top, either under vacuum or at atmospheric pressure. As the airlock rotates, in a counter-clockwise direction as a standard, the upward facing pocket will fill with material. The rotor will continue to rotate, allowing the next pocket to be filled, while moving the filled pocket towards the bottom of the airlock. The tight clearances between the blades or blade tips and the airlock casing create the seal between the different pressures of the two sides of the system.

In the blow-thru model, as seen in **Figure 2-2**, a pressurized stream of air enters at the bottom of the rear end plate. As the filled pockets rotate to the bottom, the product enters the pressurized air stream and is carried through the outlet at the bottom of the front end plate to the discharge side of the system. The motion of the discharged product is perpendicular to the rotation of the airlock rotor. Blow-thru models will always function with a pressurized air stream on the outlet side of the airlock, but can function with either vacuum or atmospheric pressure on the inlet side.

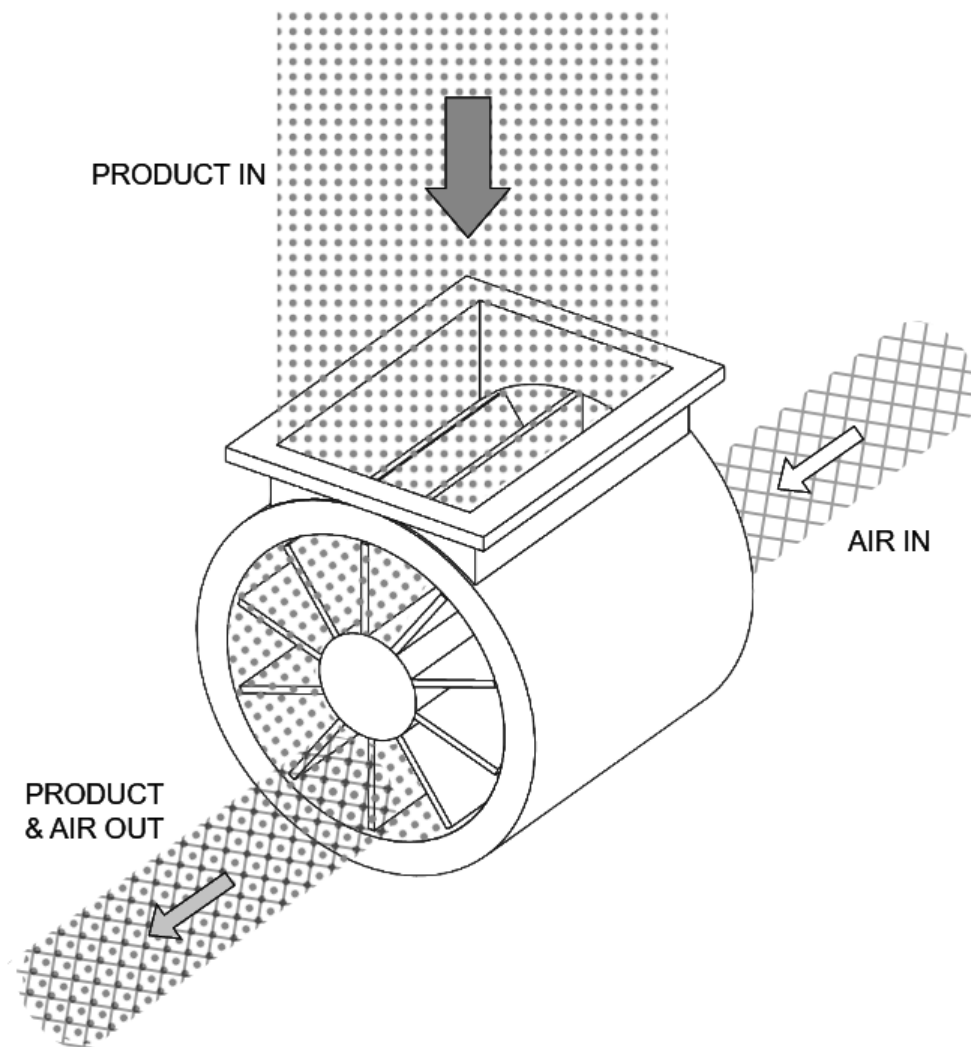

Figure 2-2: Blow-thru style airlock

In the drop-thru model, as seen in **Figure 2-3**, a pressurized stream of air enters the product collection device, commonly a pan or U-trough style. As the filled pockets rotate to the bottom, the product falls into the collection device, entering the pressurized air stream, and is carried through the conveying lines connected to the collection device. The motion of the discharged product is parallel to the tangential direction of motion of the rotor blade tip at the bottom of the airlock. For example, when viewed from the driven end of the airlock, the product would move from left to right through the collection device with the standard counter-clockwise rotor rotation. With a collection device and pressurized air stream connected to the outlet side of the airlock, the inlet side will function under vacuum or atmospheric pressure.

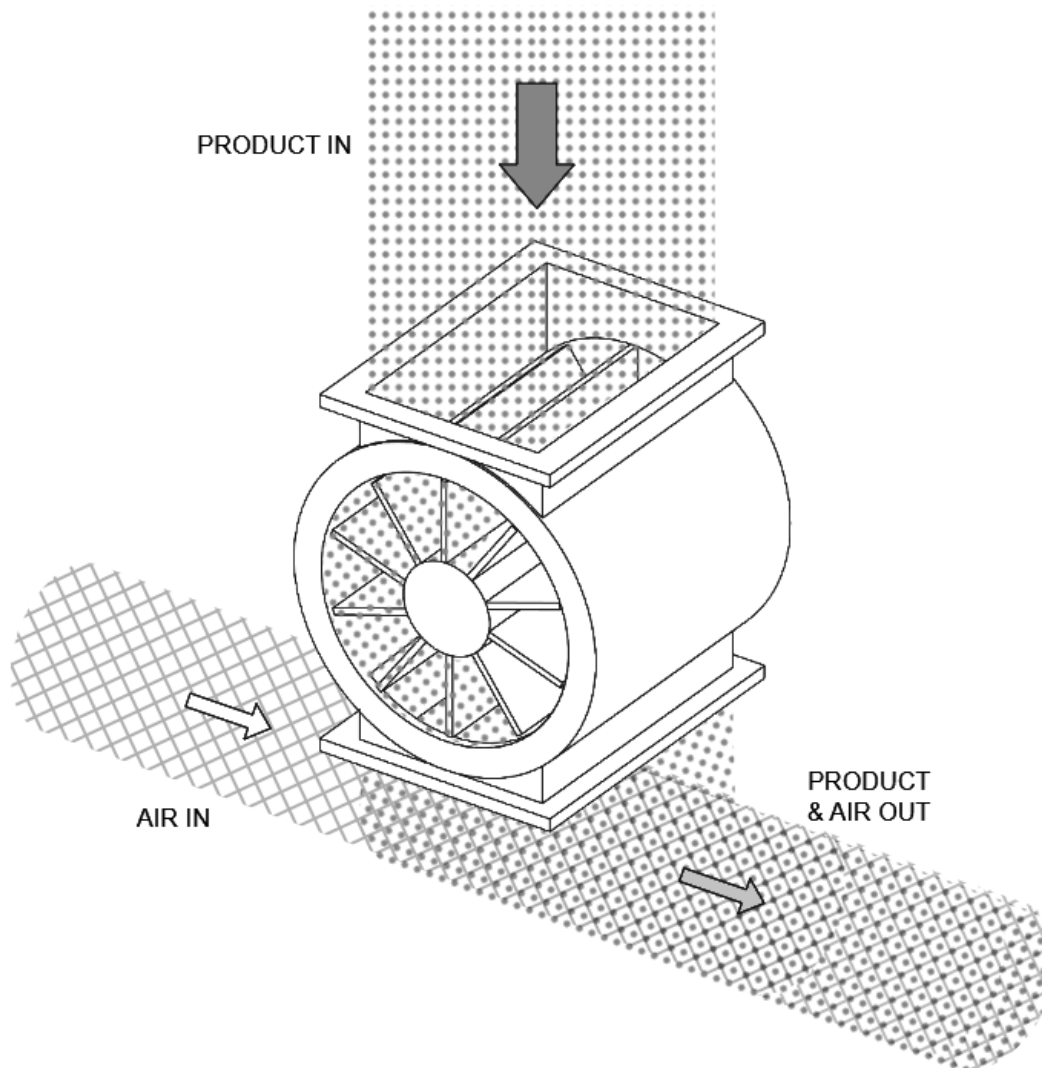

Figure 2-3: Drop-thru style airlock with pressurized outlet

The drop-thru model, as seen in **Figure 2-4**, can also function with atmospheric pressure on the outlet side. In this application, as the filled pockets rotate to the bottom, the product will fall into a large collection device, such as a bin. With a system operating with atmospheric pressure on the outlet side, the inlet side may be under vacuum, or atmospheric pressure if used as a metering device.

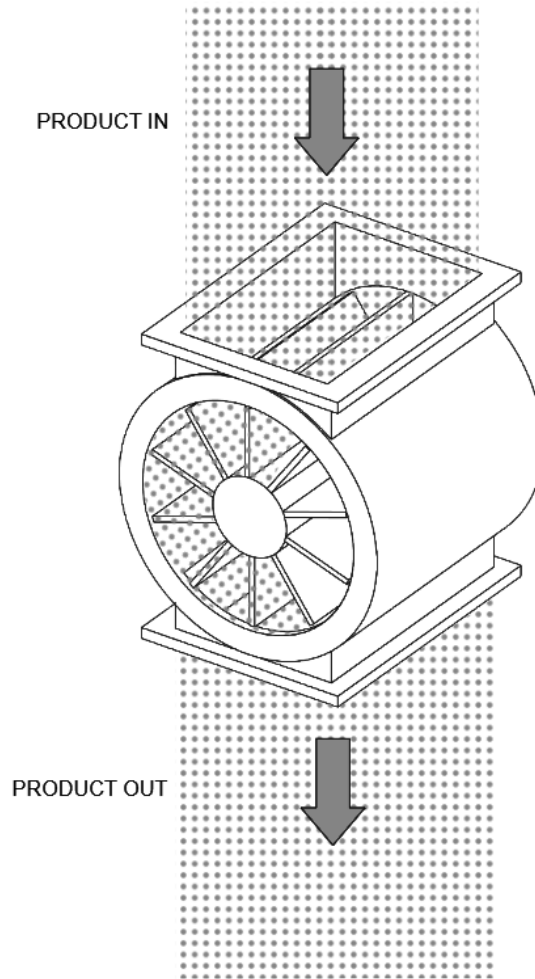

Figure 2-4: Drop-thru style airlock with atmospheric pressure outlet



Machine Configuration

AIRLOCK MODELS

MODEL SIZES

Walinga airlocks are available in a variety of sizes. To identify the size of your airlock, refer to the embossed model label on the side of the airlock casing or on the face of the end plate as seen in **Figure 3-1**.

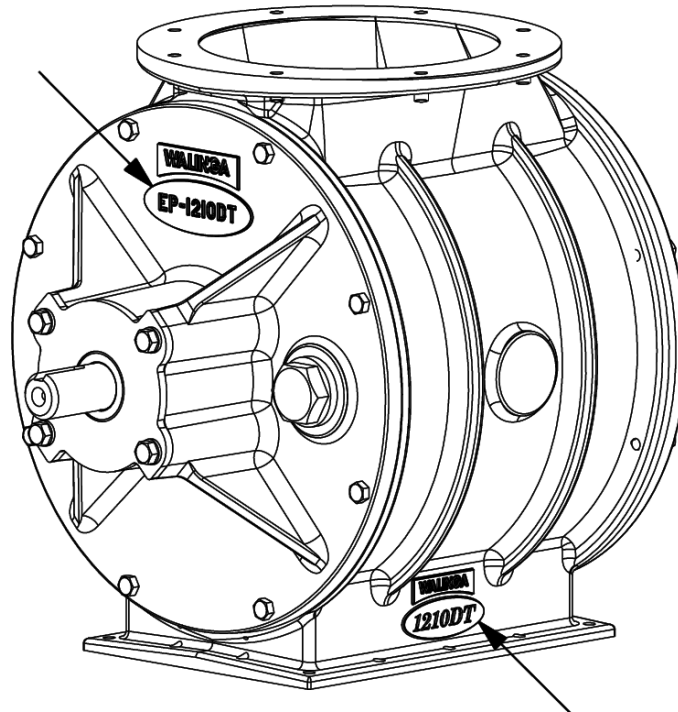

Figure 3-1: Model identification

If your model does not have an embossed model size, refer to **Table 3-1** for the reference dimensions of each specific model for identification.

Table 3-1: Airlock model sizes

		Interior Casing Diameter	Rotor Length	Inlet/Outlet Diameter	Capacity
Blow-Thru	1314-4	12.9 in (32.8 cm)	14.3 in (36.3 cm)	4 in (10.2 cm)	0.8 cu ft/rev (23 L/rev)
	1314-5	12.9 in (32.8 cm)	14.3 in (36.3 cm)	5 in (12.7 cm)	0.8 cu ft/rev (23 L/rev)
	1618-6	16 in (40.6 cm)	18.3 in (46.5 cm)	6 in (15.2 cm)	1.6 cu ft/rev (45 L/rev)
	1618-7	16 in (40.6 cm)	18.3 in (46.5 cm)	7 in (17.8 cm)	1.6 cu ft/rev (45 L/rev)
	2018-7	20 in (50.8 cm)	18.3 in (46.5 cm)	7 in (17.8 cm)	2.69 cu ft/rev (76 L/rev)
	2224-8	22 in (55.9 cm)	24 in (61.0 cm)	8 in (20.3 cm)	4.44 cu ft/rev (126 L/rev)
Drop-Thru	1008	10 in (25.4 cm)	8 in (20.3 cm)	N/A	0.28 cu ft/rev (8 L/rev)
	1210	12 in (30.5 cm)	10 in (25.4 cm)	N/A	0.55 cu ft/rev (16 L/rev)
	1314	12.9 in (32.8 cm)	14.3 in (36.3 cm)	N/A	0.8 cu ft/rev (23 L/rev)
	1618	16 in (40.6 cm)	18.3 in (46.5 cm)	N/A	1.6 cu ft/rev (45 L/rev)
	2224	22 in (55.9 cm)	24 in (61.0 cm)	N/A	4.44 cu ft/rev (126 L/rev)

MODEL VARIATIONS**GENERAL****BLOW-THRU (BT)**

Product enters through the top of the airlock (usually under vacuum) and is forced out of outlet on the bottom edge of the front end plate by a stream of pressurized air entering from the rear end plate. This style is better suited for lighter products or where cross contamination is a concern.

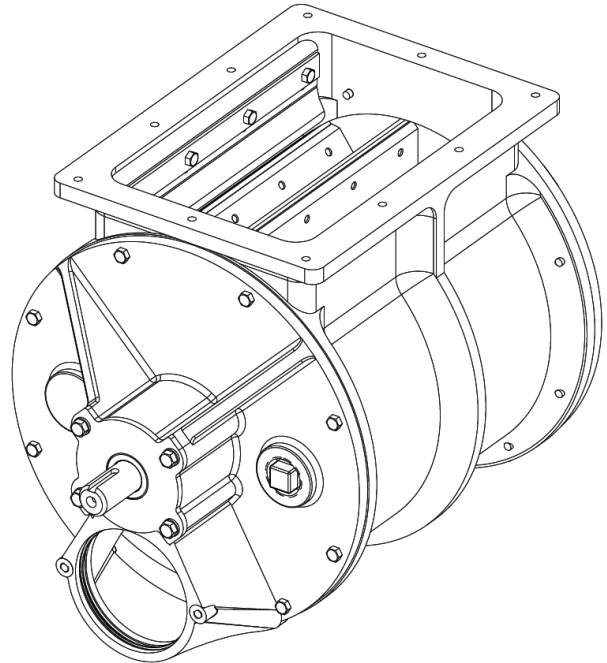
**DROP-THRU (DT)**

Product enters through the top of the airlock and drops out through the bottom. The inlet can be under vacuum or atmospheric pressure, and the outlet can be pressurized or at atmospheric pressure. The pressurized air flow should be aligned tangentially with the rotation of the rotor blades. This style is better suited for heavier products and can be used in series with multiple airlocks.

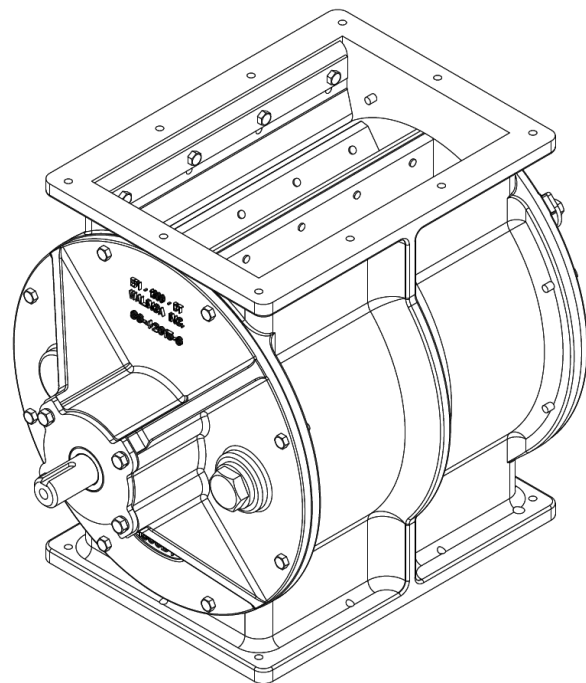

STANDARD PROFILE (-*A)

The standard profile for blow-thru airlocks features a circular inner surface of the casing, maintaining the same clearance between the casing and rotor blade tips at all points during rotation.

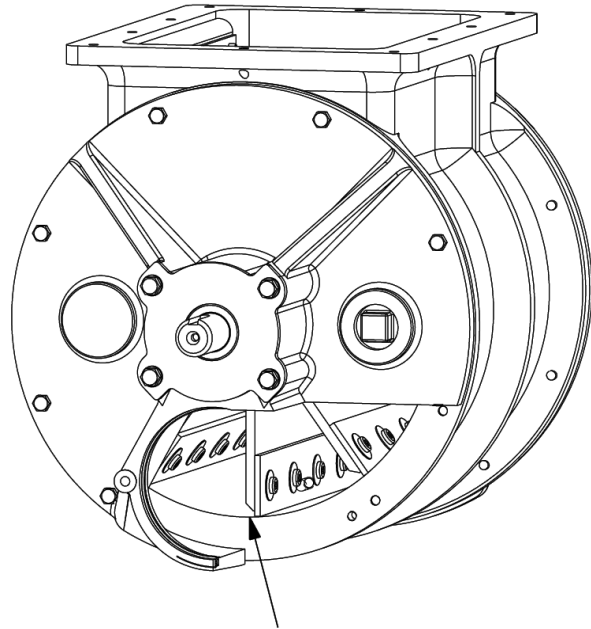
**EXTENDED PROFILE (-*B)**

The extended profile for blow-thru airlocks features a lowered portion of the casing at the bottom, creating an extra pocket of space. This pocket allows for improved air and product flow through the outlet of the airlock. This variation is only available for 1314-5 airlocks.

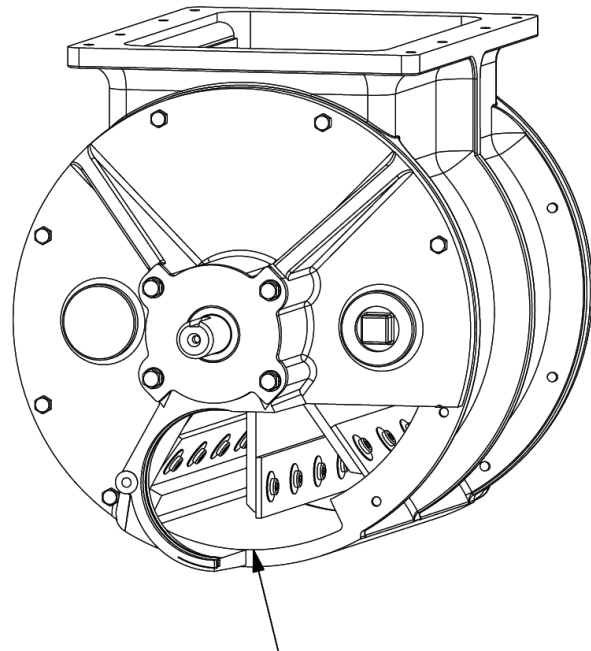

ABRASIVE (ABR)

Purge ports located in both end plates provide continuous positive pressure to the bearing cavity, preventing product buildup in the bearing and seal area. This feature is used when conveying abrasive materials or powders to prevent premature wear and damage.

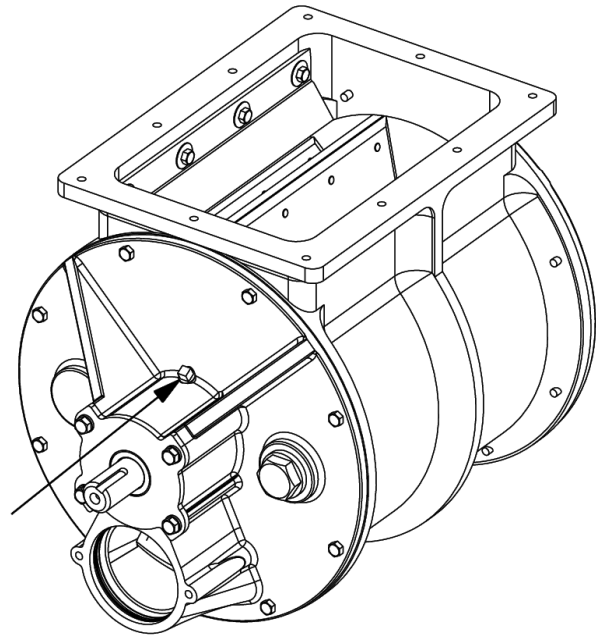
**HARD COATING (HC)**

A hard coating is applied to the interior machined surfaces of the casing and/or end plates, providing improved wear resistance.

HALAR COATING (HALAR)

Alternative coatings may be applied to the interior machined surfaces of the casing, end plates, and/or rotor blades and shaft. These coatings provide corrosion and abrasion protection as well as a low-friction surface to prevent hang-up of oily products.

ROTOR

FIXED ROTOR (FXR)

The rotor is fixed in position along the shaft direction using a tapered bearing and lock nut. This is the standard rotor style and provides decreased end plate wear.

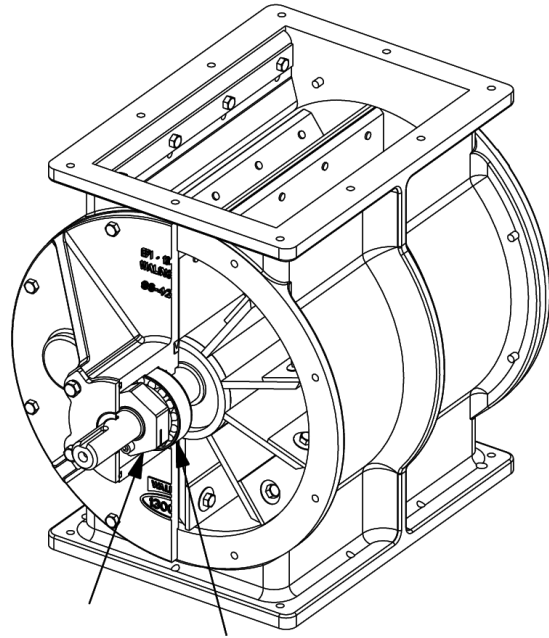

FLOATING ROTOR (FR)

The rotor is supported by a ball bearing, axially fixed to prevent end plate wear with either a locking collar integrated in the bearing, or a specialized spacer ring.

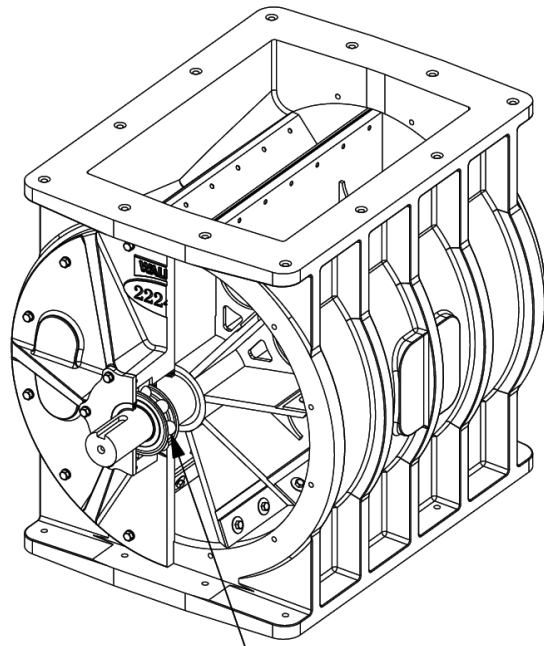

CLOSED ROTOR (CLSD RTR)

Plates are permanently affixed to each end of the rotor blades to prevent product from contacting the end plates. This feature reduces the wear and damage to the end plates and is used with abrasive products or products mixed with sand, dirt, or dust.

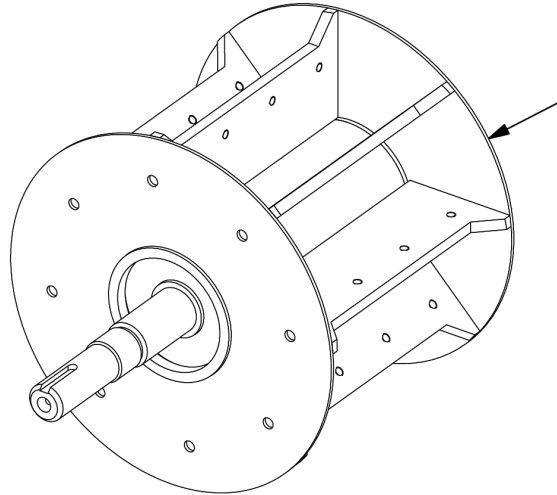
**OUTBOARD BEARING (OB)**

The shaft bearing is mounted outside of the end plate to reduce the potential for heat buildup in the assembly, minimize fire hazards, and provide NFPA standard compliance.

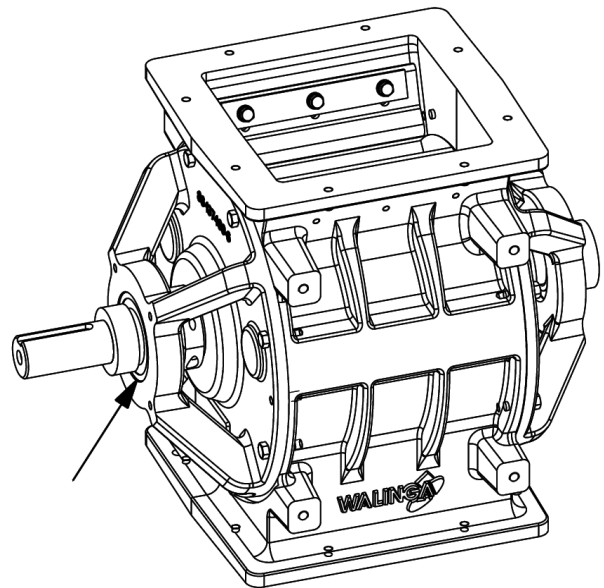

STAINLESS STEEL ROTOR (SS RTR)

The rotor shaft, blades and tips are made of stainless steel. This style is used in specialized applications to prevent product discoloration or possible chemical reactions.

CLOCKWISE (CW)

When viewed from the driven end, the rotor rotates in a clockwise direction. This style can be used in special circumstances where there may be conflicts due to limited space and mounting the motor/gearbox and the direction of the product flow.

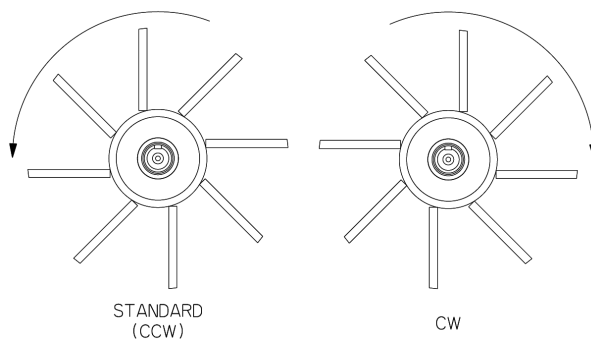

BLADE TIPS

HARDOX SQUARE (HXS)

The standard adjustable blade tips are made from Hardox material with squared edges to provide more durability. This style provides adjustment and replacement capabilities to maintain proper clearances.

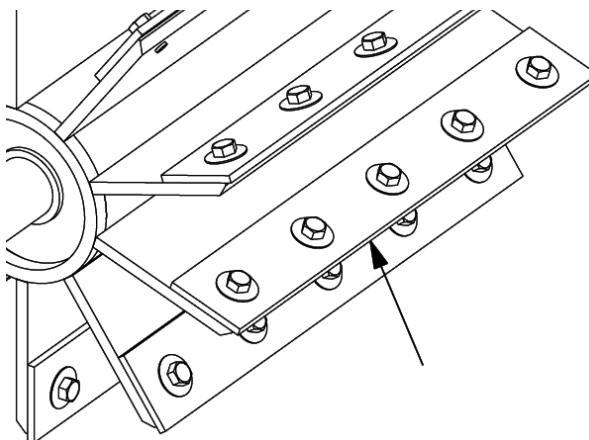

HARDOX BEVEL (HXB)

The adjustable tips made of Hardox material can also have beveled edges when conveying fibrous or long grain products to allow the tip to cut through the product to reduce the risk of binding, while maintaining the clearance adjustment and replacement capabilities.

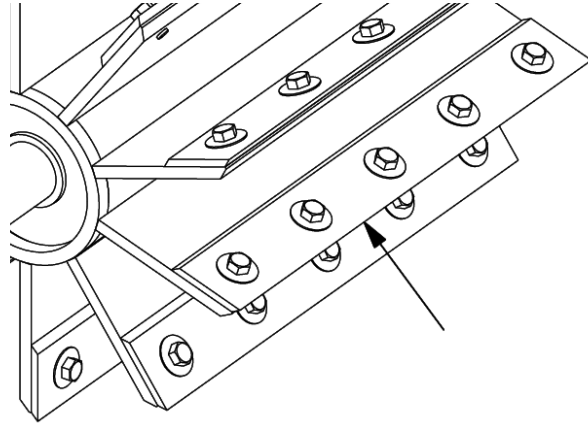

FLEXIBLE TIP (FLEX)

The adjustable tips can also be made of a flexible material such as rubber or urethane to allow the tip to flex around any debris that may be present in the product, reducing casing and rotor wear. This style is beneficial for use with dirty products or unprocessed grains that may have foreign debris, as well as long grain or fibrous products, but can only be used in low pressure systems less than 5 psi. Flexible tips are mounted to a specially designed rotor assembly referred to as a V-Rotor (V-RTR), that features notched blades to allow for proper movement of the flexible tips.

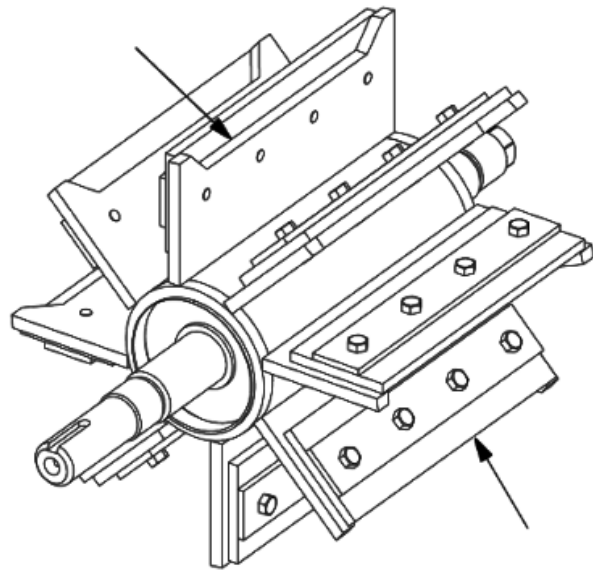

SOLID BLADE SQUARE (SOLID)

The rotor blade, with squared edges, extends from the rotor shaft to the proper clearance from the casing without the need for adjustable tips.

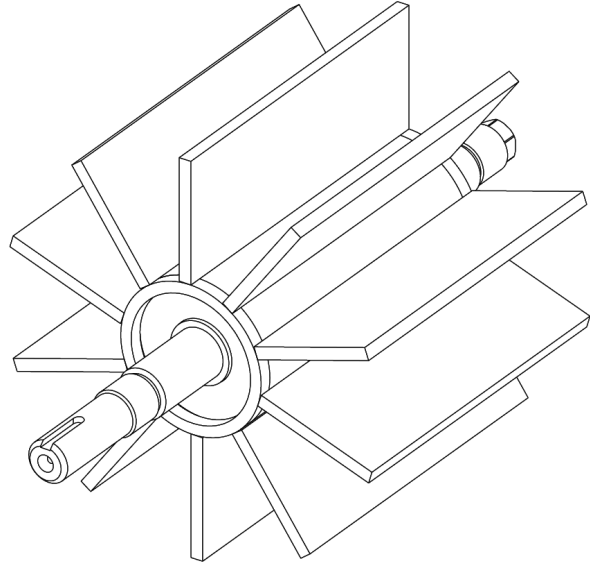
**SOLID BLADE BEVEL (BVL)**

The rotor blade, with beveled edges, extends from the rotor shaft to the proper clearance from the casing without the need for adjustable tips. The beveled edge allows the blade to cut through the product to reduce the risk of binding of the rotor.

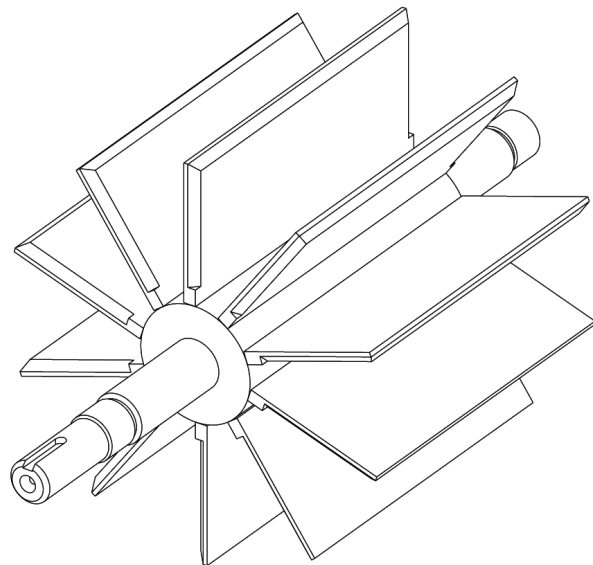



PAGE INTENTIONALLY LEFT BLANK



Safety

AIRLOCK MODELS

SAFETY ALERT SYMBOL



This safety alert symbol means: **ATTENTION! BECOME ALERT! YOUR SAFETY IS INVOLVED!**

The safety alert symbol identifies important safety messages on the airlock and in the operator's manual. When you see this symbol, be alert to the possibility of personal injury or death. Follow the instructions in the safety message.

Safety is one of the top priorities and should always be taken into consideration because:

- Accidents disable and kill
- Accidents cost
- Accidents can be avoided

SIGNAL WORDS

Take note of the signal words **DANGER**, **WARNING**, and **CAUTION** when used with a safety message, as well as the use of the words **IMPORTANT** and **NOTE**. The appropriate signal word for each message has been selected using the following guidelines:

DANGER	Indicates an imminently hazardous situation that, if not avoided, will result in death or serious injury. This signal word is limited to the most extreme situations, typically for machine components that, for functional purposes, cannot be guarded. The associated color is red.
WARNING	Indicates a potentially hazardous situation that, if not avoided, could result in death or serious injury, and includes hazards that are exposed when guards are removed. It may also be used to alert against unsafe practices. The associated color is orange.
CAUTION	Indicates a potentially hazardous situation that, if not avoided, may result in minor or moderate injury. It may also be used to alert against unsafe practices. The associated color is yellow.
IMPORTANT	Indicates a potentially hazardous situation that, if not avoided, may result in damage to the machine. It may also be used to alert against unsafe practices. The associated color is blue or white.
NOTE	Indicates supplementary information that the operator must be aware of for the safe or proper use of the machine. The associated color is blue or white.

GENERAL SAFETY

You are responsible for the **safe** operation and maintenance of your airlock. **You** must ensure that you and anyone else who will operate, maintain, or work around your pneumatic conveying equipment is familiar with the operating and maintenance procedures and safety information contained in this manual. This manual will provide information for safety practices that must be adhered to while operating an airlock. Remember, **you** are the key to safety. Good safety practices not only protect you, but also the people around you. Make good safety practices a working part of your safety program. Be certain that **everyone** operating the pneumatic conveying equipment is familiar with the recommended procedures and follows all safety precautions. Remember, most accidents can be prevented; do not risk injury or death.

Owners must provide operating instructions to operators or employees before initially allowing them to operate the equipment, and must review this information at least annually thereafter. The most important safety feature of Walinga equipment is a **safe** operator. It is the operator's responsibility to read and understand all aspects of this manual and to follow all safety and operational instructions. An individual who has not read, understood, and been trained to follow all operation and safety procedures is considered an untrained operator and is unqualified and unauthorized to operate an airlock. Untrained operators expose themselves and bystanders to potential serious injury or death.

Before servicing, adjusting, repairing, or unplugging an airlock, place all controls in neutral, stop and lock-out the power source, and wait for all moving parts to stop.

In case of emergency, keep a first-aid kit and fire extinguisher readily available and stored in a highly visible place. Be familiar with the use of each of these tools. Also keep the phone number for the emergency medical center for your area readily available.

Use appropriate personal protective equipment including, but not limited to: a hard hat, protective shoes with slip-resistant soles, protective glasses or goggles, heavy gloves, wet weather gear, and hearing protection. Long hair and loose clothing must be secured to avoid potential injury as a result of coming into contact with moving or rotating components of the airlock. Hands and feet must also be kept clear of any moving or rotating components.

Ensure all electrical equipment is properly grounded. All electrical connections made to the airlock must be in compliance and accordance with the National Electric Code (NFPA 70).

In order to provide a better view or visualization, certain diagrams in this manual may show an assembly or machine feature with a safety shield or guard removed. This is for illustrative purposes only. Equipment must never be operated in this condition. Keep all guards and shields in place. If it is necessary to remove a shield or guard for maintenance or adjustment, the shield or guard must be replaced prior to use.

Replace any safety sign or instructional sign that has been damaged or become illegible. The most common locations and a reproduction of the safety signs located on pneumatic conveying systems using an airlock are outlined later in this section. In addition to the design and configuration of this implement, including safety signs and safety equipment, hazard control and accident prevention are dependent upon the awareness, concern, prudence, and proper training of personnel involved in the operation, transport, maintenance, and storage of the machine. Refer to the safety messages and operational instructions in each of the appropriate sections of the auxiliary equipment and machine manuals. Pay careful attention to the safety signs affixed to the auxiliary equipment and the machine.

Never use alcoholic beverages, narcotics, or other intoxicants which could hinder alertness or coordination while operating an airlock. Consult your doctor about operating this machine while taking prescription medications.

Under no circumstances should young children be allowed to work with this equipment. Do not allow children or any other individuals to climb on or play around the airlock at any time. This equipment is dangerous to children and individuals unfamiliar with its operation. The operator must be a responsible, properly trained, and physically able person familiar with farm machinery and trained in the airlock's operation. If there are elderly individuals assisting with farm work, their physical limitations must be recognized and accommodated. Do not allow any individuals to operate or assemble this machine until they have read and understood the safety precautions and operational procedures in this manual.

Never exceed the limits of a piece of machinery. If its ability to perform a task, or to do so safely, is in question, do **not** attempt it. Do not modify the equipment in any way. Unauthorized modification may result in serious injury or death and may impair the function, safety or life of the equipment, as well as void the warranty.

INSTALLATION SAFETY

- Disconnect and remove all mechanical locks, anchor chains and any other transport devices that would hinder or prohibit the normal function of the airlock upon start-up. Serious damage to the machine and/or personal injury to the operator or bystanders may result from attempting to operate the machine while mechanical locking devices are still attached and secured.
- Ensure there is a minimum of one additional individual available for assistance with elevating, moving, or connecting other equipment.

STORAGE SAFETY

- Store the equipment in an area away from human activity.
- The storage area should be dry with a firm, level surface.
- Do not permit children to play on or around the stored machine.
- Ensure all mechanical locks are safely and positively connected.
- Coat internal surfaces with a rust inhibitor to prevent damage upon use after storage.

PRE-OPERATION SAFETY

- Safety is a primary concern in the design and manufacturing of Walinga products. However, these efforts can be negated by a single careless act of an operator or bystander.
- It is the responsibility of the operator to read and understand all safety and operational instructions contained within the operator's manual and the manuals of any auxiliary equipment. Working with unfamiliar equipment can lead to careless injuries. Ensure you and any individual who will be working with or around the airlock understands the information provided in the operator's manuals and is instructed in the safe and proper use of the machine.
- Refer to the auxiliary equipment's operator's manual to become familiar with the controls of the airlock and know how to stop the airlock and any other auxiliary equipment quickly in the event of an emergency.
- Properly train all new personnel and review instructions frequently with existing workers. Ensure only a properly trained and physically able individual will operate the machine. Any individual who has not read and understood all operating and safety procedures is not qualified to operate the machine.
- Ensure all necessary personal protective equipment including a hard hat, safety glasses or goggles, safety shoes, gloves, and wet weather gear are in good condition. Do not allow loose long hair, loose fitting clothing, or jewelry to be around the equipment.
- Clear the working area of debris, trash or hidden obstacles that may be hooked or snagged, causing injury, damage or tripping hazards.
- Operate only in daylight or with sufficient artificial lighting.
- Ensure the machine is properly anchored, adjusted and in good operating condition. Check the machine over for any loose bolts, worn parts, cracks, leaks, etc., and make any necessary repairs. Always follow the maintenance instructions.
- Ensure that all safety shielding and guarding and safety signs are properly installed and secured, and are in good condition.
- The rotating blades of the airlock rotor can cause serious bodily injury. The inlet and outlet of the airlock must always be properly guarded to prevent contact with the rotor.

OPERATIONAL SAFETY

- Read and understand the operator's manual and all safety signs before use.
- Do not operate when any guards are damaged or removed. Install and secure all guards before operating.
- Do not open any access door to the airlock while in operation.
- Keep hands, feet, clothing, hair, and jewelry away from all moving and/or rotating parts.
- Do not allow any individuals to climb on the airlock at any time.
- Clear the area of all bystanders, especially small children, before operation.
- Keep all safety signs clean and unobstructed.
- Wear appropriate personal protective equipment while operating.
- In the event of a blockage in the airlock, operate the airlock in reverse for a short period of time until the blockage clears. Do not operate the airlock in reverse for extended periods of time or damage to the rotor will occur. Never reach into the airlock with hands or tools while in operation to clear an obstruction. All power sources must be disconnected and/or locked out before any guards or access points are opened to manually dislodge obstructions.

MAINTENANCE SAFETY

- Read, understand and follow all operating, maintenance and safety information in the operator's manual.
- Clear the area of bystanders, especially small children, when carrying out any maintenance or repairs or making any adjustments.
- Follow good shop practices:
 - Keep the service area clean and dry.
 - Ensure electrical outlets and tools are properly grounded.
 - Use adequate lightning for the job at hand.
- Ensure a fire extinguisher and first aid kit are available, and know how to use them.
- Place all controls in neutral, stop and lock-out the power source, and wait for all moving parts to stop before servicing, adjusting or maintaining.
- Use required personal protective equipment previously outlined.
- Use only tools, jacks and hoists of sufficient capacity for the job.
- Keep hands, feet, hair, clothing, and jewelry away from all moving and/or rotating parts.
- Ensure all guards are in place and secured when maintenance work is complete.

MACHINE SAFETY SIGNS

The safety signs affixed to the airlock and auxiliary equipment provide important information regarding your safety and the safe operation of the machine. Familiarize yourself with all safety signs before operation.

- Safety signs must be clean and legible at all times.
- Replace any safety signs that are missing, damaged, or have become illegible.
- Any replaced parts that previously displayed a safety sign, must display the current safety sign.
- Safety signs are available at no cost from your representative, dealer, or directly from Walinga.

If a safety sign has become damaged, illegible or a new safety sign must be installed on a replacement component, proceed as follows:

1. Ensure the installation area is clean and dry
2. Ensure the temperature of the equipment is above 50 °F (10 °C).
3. Locate the correct position of the safety sign before removing the backing paper.
4. Remove the smallest portion of the split backing paper.
5. Align the safety sign over the correct position and carefully press the small portion with the exposed adhesive backing in place.
6. Slowly peel back the remaining paper and carefully smooth the remaining portions of the safety sign in place.
7. Small air pockets can be pierced with a pin and smoothed out using the backing paper.

Safety signs affixed to pneumatic conveying equipment are standardized as follows:

- Danger safety signs are red in color
- Warning safety signs are orange in color
- Caution safety signs are yellow in color
- Informational safety signs are white or blue in color
- Each safety sign is printed with its respective Walinga part number located in the bottom right corner. Reference this number on the safety sign, or identified in the following reproductions, to obtain replacement safety signs.

Due to the wide variety of pneumatic conveying systems that utilize an airlock, refer to the operator's manual of the auxiliary equipment for the exact location, quantity and part number of each safety sign. The following safety signs are commonly used in close proximity and in relation to an airlock:

Figure 4-1

Part Number: 53-17704-6

Approximate Location:

Located on the inner surface of the airlock inlet area below the guards, as well as around the drive shaft if equipped with a guard



Figure 4-2

Part Number: 53-18289-6

Approximate Location:

Located at all openings of the airlock including the inlet, outlet, and any access doors



Figure 4-3**Part Number:** 53-18542-6**Approximate Location:**

Varies depending on the type and the model of the pneumatic conveying system

NOTE:
**Reset Airlock
Every 60000 Bushels
(1600 Tonnes)**
(See Owner's Manual for Settings)

53-18542-6

Figure 4-4**Part Number:** 53-137850-6**Approximate Location:**

Varies depending on the type and the model of the pneumatic conveying system

NOTICE

**COAT INTERNAL SURFACES
WITH A RUST INHIBITOR PRIOR TO
STORAGE OR PROLONGED PERIODS
WHEN THE UNIT WILL NOT BE IN USE.**

Figure 4-5**Part Number:** 53-04733-6**Approximate Location:**

Located at the driven end of the airlock, positioned so the arrow indicates the correct rotational direction (points to left side of airlock for standard counter-clockwise rotation)

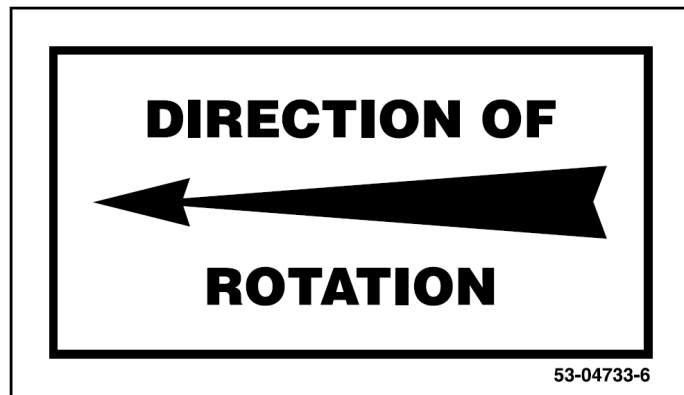
**Figure 4-6****Part Number:** 53-82427-6**Approximate Location:**

Located on the discharge line, positioned so the arrow is aligned with the movement of the conveyed material

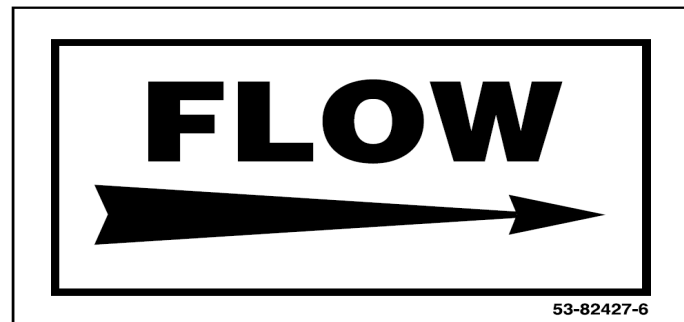



Machine Life-Cycle Procedures

AIRLOCK MODELS

RECEPTION, ASSEMBLY AND INITIAL SET-UP

ASSEMBLY

Airlocks that are shipped separately or as part of a partially assembled system, require extra precautions to be taken to protect the internals of the airlock. To prevent premature failure due to dirt, dust, or debris that may enter during shipping, exposed airlocks will be fitted with shipping debris covers. The covers, as seen in **Figure 5-1** must be removed from the airlock during assembly and before any operation of the airlock is started. Do not dispose of the debris covers as they may be used during transport or storage of the airlock.

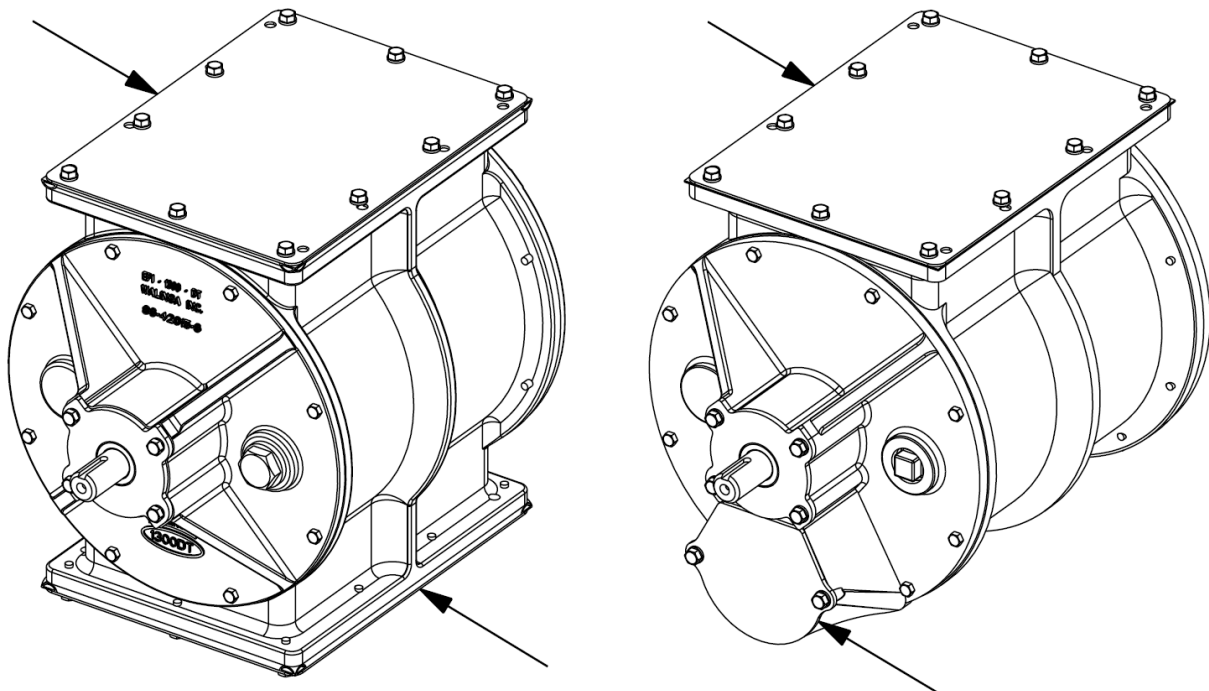

Figure 5-1: Airlock debris covers

Due to the wide range of applications and systems in which a Walinga airlock may be used, refer to the operator's manual of the auxiliary equipment for any additional procedures required for assembly upon initial reception of the airlock.

INITIAL SET-UP

To ensure safe and efficient operation, upon complete assembly and before initial use of the machine, perform the following inspections:

- Ensure the dust hazard analysis as required by NFPA 652 has been completed and the incorporation of the Walinga equipment complies with all relevant standards and regulations.
- Ensure the area is clear of any bystanders and individuals not involved in the operation of the machine, especially small children.
- To maintain proper stability, ensure all equipment is located on a flat surface that is solid, dry and clear of any other equipment. As applicable, engage the holding brake (if fitted), place wheel chocks, and anchor equipment securely.
- Ensure that any individuals involved in the operation of the machine or in close proximity to the machine are equipped with the required personal protective equipment as outlined in **Section 4: Safety**, including but not limited to: a hard hat, protective shoes with slip-resistant soles, protective glasses or goggles, heavy gloves, wet weather gear, and hearing protection. Long hair and loose clothing must be secured and jewelry should be removed to avoid personal injury as a result of coming into contact with moving or rotating components.
- Check to ensure all lubrication and grease points have been properly lubricated. Reference **Section 7: Maintenance and Adjustments** for detailed lubrication procedures and the required lubrication frequency.
- Check to ensure all guards are correctly positioned, closed and secured before operation to prevent any personal injury or damage. All guards must be closed and secured with fasteners before any operation.
- Ensure all mechanical locks, anchor chains, and any other transport devices that would hinder or prohibit the normal function or movement of the airlock are removed. Serious damage to the machine and/or personal injury to the operator or bystanders may result from attempting to operate the machine while mechanical locking devices are attached.

BREAK-IN INSPECTIONS

There are no operational restrictions on airlocks when used for the first time, however, during the initial break-in period, the following mechanical features should be inspected more frequently than the recommended maintenance schedule. There may be additional break-in inspections required for auxiliary equipment; refer to any auxiliary equipment operator's manuals for required inspections and frequency. With reference to **Section 7: Maintenance and Adjustments**, inspect the airlock as follows:

After operating the airlock for 2 hours:

1. Clear the area of all bystanders, especially small children.
2. Place all controls in neutral, stop and lock-out the power source, and wait for all moving parts to stop.
3. Re-torque and tighten all fasteners and hardware.
4. Turn the airlock by hand, ensuring it rotates freely.
5. Listen for excessive noise produced by the bearings or rotors.
6. Check the temperature of the bearings, rotor casing and surrounding areas.
7. Inspect the inlet and outlet flanges for air leaks.
8. For abrasive style airlocks, remove the purge airline and inspect for material build-up. If there is more than low levels of dust in the airline, increase the pressure and/or volume of air entering the cavity from the purge system.

After operating the airlock for 10 hours:

1. Clear the area of all bystanders, especially small children.
2. Place all controls in neutral, stop and lock-out the power source, and wait for all moving parts to stop.
3. Repeat all checks and adjustments performed at the 2 hour inspection.

STORAGE

To prevent unnecessary down-time when preparing the airlock for use after storage, it is important to carefully follow the storage preparation procedures.

To prepare the airlock for storage, proceed as follows:

1. Clear the area of bystanders, especially small children.
2. Place all controls in neutral, stop and lock-out the power source, and wait for all moving parts to stop.
3. Thoroughly inspect the airlock for any damaged or worn components; repair or replace any components as required before storage with reference to **Section 7: Maintenance and Adjustments** to prevent down-time at the beginning of the next season.
4. Wash the airlock thoroughly using a water hose or pressure washer to remove all dirt, dust, debris, and residue. The internal surfaces of the airlock can be cleaned through flushing. To flush the internal surfaces, proceed as follows:
 - a. Position the outlet/discharge line to allow free discharge of water.
 - b. Run the airlock at a high idle speed with the airlock rotating.
 - c. Allow water to enter the airlock inlet for several minutes, allowing time for the water to wash out the casing interior, the rotating airlock blades, inlet and outlet surfaces, and the connected discharge components.
 - d. Stop the water flow into the inlet and continue to run the airlock for several minutes to allow all interior surfaces to completely dry.
 - e. When conveying materials with oily characteristics or high moisture content, including milled feeds, the airlock may need to be flushed on a more regular basis to remove residue build-up. Oily residues may require flushing and soaking with a suitable solvent to dissolve build-up. Any non-food-grade solvents must be cleaned from the machine using hot water and/or detergent flushing. Ensure that any solvent used is acceptable for the intended market of the conveyed products.
5. With reference to **Section 7: Maintenance and Adjustments**, lubricate all grease points. Ensure all grease cavities have been filled with grease to remove any water residue from washing.
6. Coat the internal surfaces of the airlock with a rust inhibitor/anti-corrosive oil.
7. Touch up all paint nicks and scratches to prevent rusting.
8. Install a debris cover on the inlet and/or outlet if they are exposed to prevent accumulation of dirt, dust and debris and further limit rusting of the internal surfaces.
9. Move the airlock to its storage position. The storage position should be dry, level and free of debris, and does not have frequent human activity in the vicinity.

After storage, refer to **Section 7: Maintenance and Adjustments** to ensure all necessary maintenance tasks are completed. Once the required maintenance tasks have been completed, proceed to the standard pre-operation checks as outlined in **Section 6: Operation** and resume normal operation.

END OF LIFE

Upon completion of the functional life of the airlock, Walinga offers a rebuilding program as a cost-effective means of keeping your airlock in optimal operating condition. Contact your Walinga dealer or representative to submit your airlock and join the rebuild program.

Rebuilt and refurbished airlocks feature:

- A re-machined casing to correct out-of-round wear or damage
- Re-machined end plates to correct any damage and properly align with the casing
- New hard coating treatments to required components
- Replacement of seals, O-rings, and bearings as required
- Replacement of rotor shafts and blades as required
- New rotor blade tips
- Repainted outer surfaces

All rebuilt airlocks are tested to ensure ideal operation and inspected for proper tolerances and clearances to meet all requirements.



Operation

AIRLOCK MODELS

MACHINE FEATURES AND COMPONENTS

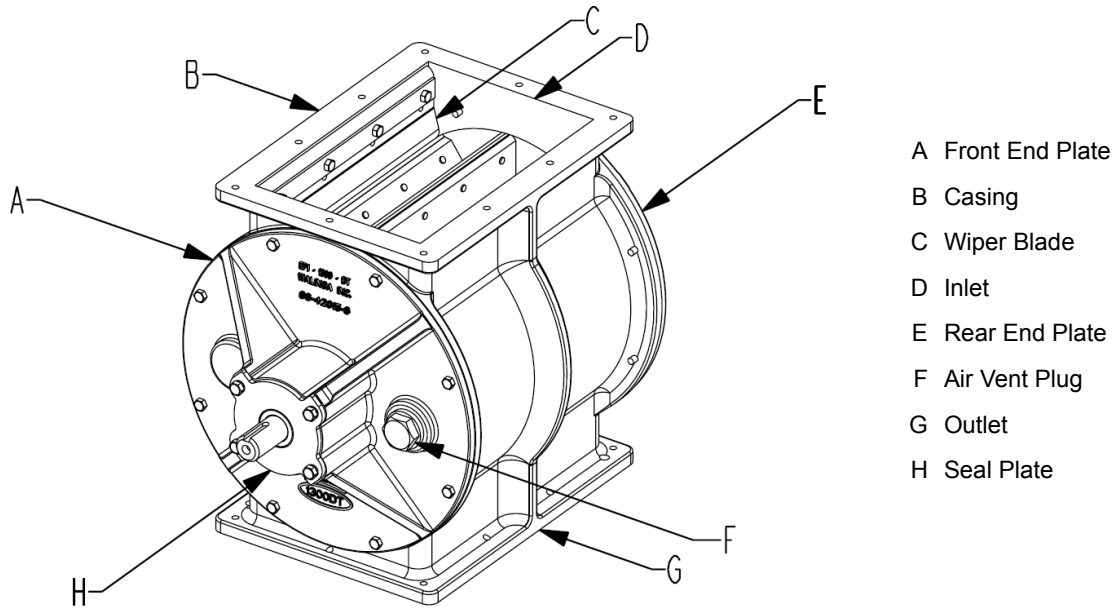

Figure 6-1: Airlock key components

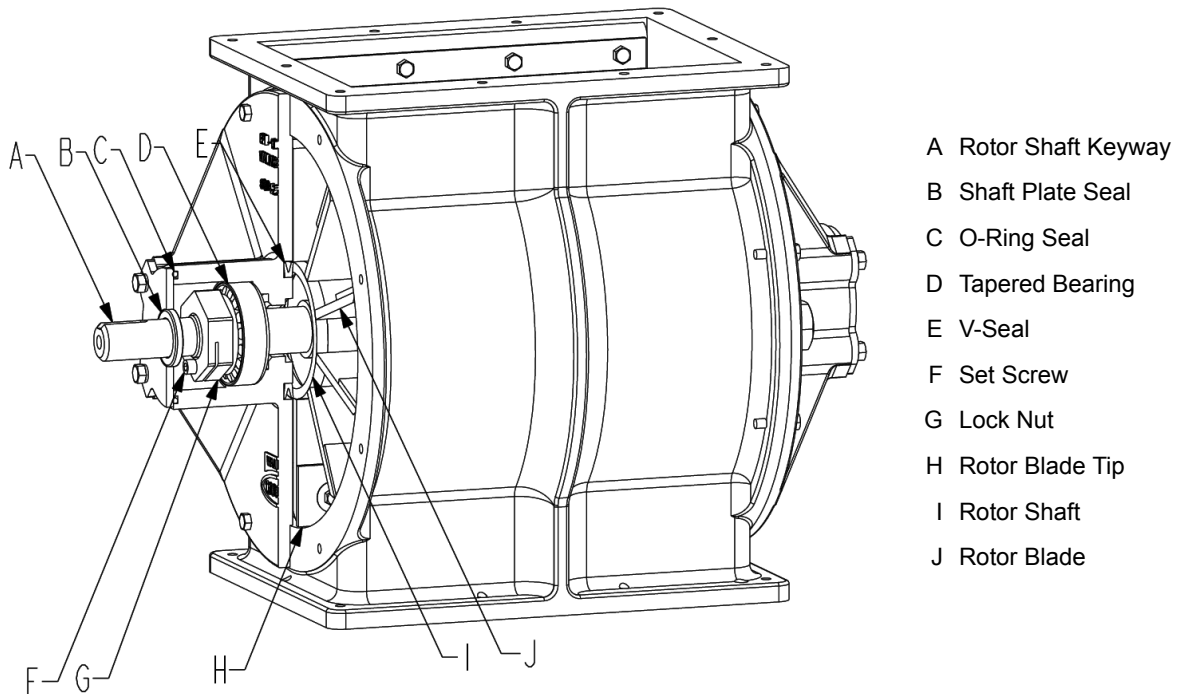

Figure 6-2: Airlock key components

CONTROLS AND DISPLAYS

Due to the wide range of applications in which a Walinga airlock may be used, refer to the operator's manual of the auxiliary equipment for specific details pertaining to controls and displays.

OPERATION

Pre-Operation Machine Preparation

For personal safety and to ensure the airlock is in good mechanical condition, the following checks must be performed before operation of the airlock:

1. Clear the area of bystanders, especially small children.
2. Ensure the airlock has been properly serviced and maintained as per the described methods and schedule as outlined in **Section 7: Maintenance and Adjustments**.
3. Refer to the operator's manual of the auxiliary equipment to ensure the airlock is sufficiently powered and that the airlock is properly connected to the system.
4. Ensure the airlock rotates freely and is not obstructed and has not accumulated dirt, dust, or debris. Clean out the interior of the airlock as necessary, ensuring the power source is properly disconnected.
5. Ensure the power source is properly connected, refer to the auxiliary equipment's operator's manual for any specific connection requirements or procedures.
6. Ensure all mechanical locking devices, anchor chains, and transport or storage devices that would hinder or prohibit the normal function of the airlock have been removed. Serious damage to the machine and/or personal injury to the operator or bystanders may result from attempting to operate the machine while mechanical locking devices are in place.
7. Close and secure all guards.

Operation of the Machine

The operation procedures for the airlock are heavily dependent on the auxiliary equipment. Refer to the operator's manual of the auxiliary equipment for operation procedures. The following are the general operating guidelines:

1. Clear the area of bystanders, especially small children.
2. Ensure the airlock rotates in the counter-clockwise direction, with the exception of airlocks specifically designed to rotate in the clockwise direction. Prolonged operation in the reverse direction will result in high wear rates of the airlock casing, product damage, and overall loss of performance.
3. Start the airlock and allow it to run for a short period of time (~30 seconds), to ensure any collection structures feeding the airlock are empty before additional product is introduced to the system.
4. For hydraulically powered airlocks, operate the system at approximately 3/4 capacity for the first 10 minutes to allow the hydraulic fluid to warm before transitioning to operating at full capacity. It should be noted that product must be conveyed for the hydraulic fluid to properly warm.
5. To operate at maximum capacity, the airlock pockets should be as full of the conveyed product as possible. To completely fill each pocket, the airlock should rotate as slow as possible. The airlock can be run too fast, not allowing the product to fill each pocket. Do not exceed the recommended speeds as detailed in the auxiliary equipment's operator's manual. The airlock speed for maximum capacity varies with each application, with dependencies including the characteristics of the products being conveyed and the diameter and length of the conveying lines.
6. If equipped, monitor the movement of the product through sight windows. At maximum capacity, the window may be covered by the product, but the product should not be stationary.
7. If equipped, monitor the discharge pressure gauge. The pressure range for maximum capacity will vary based on the application and operating conditions; however, the pressure should not exceed 15 psi (1.0 bar).

Stopping the Machine

The stopping procedures for the airlock are heavily dependent on the auxiliary equipment. Refer to the operator's manual of the auxiliary equipment for stopping procedures. The following are the general stopping guidelines for normal operation:

1. Once product has been stopped from entering the conveying system, allow the airlock and system to continue to operate for a short period of time (~30 seconds) to allow all components and conveying lines to completely empty.
2. To stop the rotation of the airlock, refer to the auxiliary equipment's operator's manual for specific instructions. The general stopping principles are as follows:
 - a. For hydraulically driven airlocks without remote operation, move the control lever for the airlock direction control to the center neutral position.
 - b. For hydraulically driven airlocks with remote operation, press the button on the remote labeled *OFF*.
 - c. For electrically driven airlocks, press the button on the control panel labeled *STOP*.
3. With reference to **Section 7: Maintenance and Adjustments**, review the maintenance schedule and perform any required maintenance on the airlock.
4. Proceed to prepare the airlock for storage or transportation with reference to **Section 5: Machine Life-Cycle Procedures**.

In emergency situations, for example, if the safety of a person is threatened, it may be necessary to immediately shut-down the airlock. To avoid potential damage to the airlock and other components, the following should only be used in an emergency situation. Refer to the operator's manual of the auxiliary equipment for any special emergency shut-down procedures.

To shut-down the airlock in an emergency, refer to the auxiliary equipment's operator's manual for specific instructions. The general emergency stopping principles are as follows:

1. For hydraulically driven airlocks without remote operation, move the control lever for the airlock direction control to the center neutral position or disengage the PTO clutch.
2. For hydraulically driven airlocks with remote operation, press the button on the remote labeled *OFF* or disengage the PTO clutch.
3. For electrically driven airlocks, press the button on the control panel labeled *KILL*, or rotate the power disconnect switch of the airlock to the *OFF* position.

OPERATING TIPS AND HINTS

To achieve the best performance from your airlock keep the following in mind:

- Keep intake lines as full as possible for maximum capacity.
- For vacuum applications, maximum capacity is achieved when using large diameter conveying lines. Only use the smaller rubber lines for final clean-up.
- Position the airlock and route the lines to minimize the number of bends and corners. If a corner is necessary, use a large radius elbow.
- Keep the conveying lines as short and straight as possible to minimize friction losses.
- If long distance moving is required, use solid metal tubing whenever and wherever possible to reduce resistance in conveying.
- If the airlock becomes jammed, use the *REVERSE* position of the airlock direction control lever to operate the airlock in the reverse direction for a short period of time to clear the obstruction. Alternate between the forward and reverse directions several times until the obstruction clears. Do not reach into the airlock with your hands or any object to clear an obstruction. If the obstruction can not be cleared through the reverse direction, or the system is not equipped to operate in the reverse direction, the obstruction must be manually removed as follows:
 - Shut down and lock out the power unit. If equipped, disconnect the hydraulic system and relieve the hydraulic pressure from the airlock motor.
 - Ensure all moving components have come to a complete stop.
 - Open the access point or remove the airlock inlet or outlet connection to gain access to the obstruction.
 - Manually remove the obstruction.
 - Check the airlock for any damage and repair or replace any components as necessary with reference to **Section 7: Maintenance and Adjustments**.
- Keep the clearance of the rotor and blade tips within the range outlined in **Section 7: Maintenance and Adjustments**, to maintain proper sealing and maximum efficiency.
- Keep all components properly lubricated to ensure smooth operation of the airlock.
- Keep the flexible tip wiper in good condition to maintain even flow, reduce wear rate, prevent out-of-round casing wear, and reduce product damage.
- Keep the operating temperature of the airlock endplates below 140 °F (60 °C) for standard airlocks equipped with “V” style seals, and below 212 °F (100 °C) for abrasive style airlocks with “CR” seals, to prevent premature failure.

TROUBLESHOOTING

Reference **Table 6-1** for assistance with some of the most common issues, causes and solutions that you may face during the operation of your airlock. If you encounter a problem that is difficult to solve, even after having referenced the following table and the troubleshooting guide of any auxiliary equipment's operator's manual, please contact your Walinga dealer or representative. Before you call, please have your operator's manual and your airlock's serial number ready and available.

For detailed procedures for the solutions, reference **Section 6: Operation** and **Section 7: Maintenance and Adjustments**.

Table 6-1: Troubleshooting for airlock

ISSUE	CAUSE	SOLUTION
Slow pick up of material	Improper tip clearances	Check that the tip clearance matches the specifications. Adjust or replace tips as required.
Slow discharge of material	Improper tip clearances	Check that the tip clearance matches the specifications. Adjust or replace tips as required.
	Incorrect airlock speed	The speed may need to be lowered or raised. Do not increase the speed higher than the recommended speed. For hydraulically driven airlocks: reset flow control so the airlock runs at the recommended speed for the conveyed material. For electrically driven airlocks: change the drive sprockets, or if equipped with a variable frequency drive (VFD), adjust the speed.
Material damage	Wiper blade damage	Replace wiper blade.
	Excessive speed	Check the speed of the airlock and reduce as required, it may be necessary to run the airlock at speeds lower than recommended for a smoother action through the airlock for more fragile products.

ISSUE	CAUSE	SOLUTION
Uneven or poor material flow	Air loss through airlock due to excessive tip clearance	Adjust the tips to decrease the clearance to the required specifications. Excessive clearance causes operating problems including bridging and erratic flow. Prolonged operation with excessive clearances will cause uneven casing wear, resulting in lower performance even after tip adjustment.
	Airlock casing not pressure vented <i>Note: venting is not usually needed in free-flowing materials with high bulk densities, such as cereal grains</i>	CAUTION: both air and excess feed may blow out of the vent hole during testing. Keep eyes and face clear of the vent hole. 1. Loosen vent plug in end plate (Figure 6-1 F) 2. Operate the airlock to transfer product, first with vent plug installed and then with vent plug removed. 3. Check whether flow improves with the vent plug removed. 4. If flow improves, fit a pressure-vent kit. Refer to Section 7: Maintenance and Adjustments . Custom-designed vented hoppers may also be used for fine products such as milled meals.
Airlock tip or flexible tip wiper breaks	Prolonged operation in reverse direction	The airlock must operate in a counter-clockwise direction when viewed from the driven end. Change the rotational direction and repair, adjust, or replace tips and flexible wiper as necessary.
	Tip wiper fouling on blade tips	Readjust the clearance of the flexible tip wiper with the blade tips..
Excessive noise	Rotor blade tips not fully seated after adjustment	It is normal to hear a light grinding noise for several hours after adjustment of the airlock tip clearances. This noise will disappear after the tips seat fully on the casing. If the noise is excessive the tips may be adjusted too tight against the casing. Re-adjust tip clearances.
	Tip clearances too tight	Check that the tip clearance matches the specifications. Adjust or replace tips as required.

ISSUE	CAUSE	SOLUTION
Excessive noise	Bearing failure	Remove the cover plate(s) and replace the bearing(s). Re-pack tapered bearings and housings with grease. Check the clearances between the rotor blades and end plates after replacing the bearing(s).
	Incorrect direction of rotation	The airlock operates continuously in one direction only. Check that the shaft rotates in a counter-clockwise direction when viewed from the driven end of the unit. Continuous operation in reverse will cause excessive wear and may damage the rotor tips, tip wiper, casing, and bearings.
Airlock stalls or motor overloads	Obstruction in airlock prevents blade rotation	Units with reversible speed controller: change the rotational direction of the airlock briefly then return to the correct direction. Repeat this several times until the object is dislodged and clears. DO NOT change the direction of rotation by reversing the wiring on 3-phase electric motors, impact damage may result. If the obstruction does not clear, follow the procedure for units without reversible speed controller.
		Units without reversible speed controller: isolate the power supply to the unit. Gain access to the obstruction through an inlet or discharge opening by removing piping or ducting, or via an inspection hatch. Remove the obstruction manually. If still unable to clear, remove the complete airlock unit for attention.
	Prolonged operation in reverse direction	The airlock operates in a counter-clockwise direction when viewed from the driven end. Damage to the rotor blades and tips due to prolonged operation in the opposite direction may cause jamming. The unit may need to be removed to assess rotor and casing damage. Repair or replace as necessary.
	Insufficient rotor or tip clearance	Check the tips and rotor clearances and adjust to the correct specifications as required.



PAGE INTENTIONALLY LEFT BLANK



Maintenance and Adjustments

AIRLOCK MODELS

MAINTENANCE SAFETY

Unsafe workshop and servicing practices increase the risk of injury around machinery. Review the following safety guidelines for important information regarding safety involved with maintenance operations.

- Read, understand and follow all operating, maintenance and safety information in the operator's manual.
- Clear the area of bystanders, especially small children, when carrying out any maintenance or repairs or making any adjustments.
- Place all controls in neutral, stop and lock-out the power source, and wait for all moving parts to stop before servicing, adjusting or maintaining.
- Support the machine with blocks or safety stands when working beneath the machine.
- Follow good shop practices:
 - a. Keep the service area clean and dry.
 - b. Ensure electrical outlets and tools are properly grounded.
 - c. Use adequate lighting for the job at hand.
- Use only tools, jacks and hoists of sufficient capacity for the job.
- Keep hands, feet, hair, and clothing away from all moving and/or rotating parts.
- Ensure all guards are in place and properly secured upon completion of maintenance.

MAINTENANCE PROCEDURES

Greasing

1. Use a hand-held grease gun for all greasing. Air powered greasing systems can damage the seals on bearings and lead to early bearing failure.
2. Wipe the grease fitting with a clean cloth before greasing to avoid injecting dirt and grit.

Abrasive Airlock Purge Line and Cavity Inspection

To reduce damage and wear when conveying products with abrasive properties, an airlock may be fitted with a purge system for the bearing and seal cavity on both end plates. To ensure the system is functioning properly with sufficient purge air pressure and volume, several checks and inspections must be performed during the initial break-in period.

To assess the functionality of the purge system, proceed as follows:

1. Ensure the system is equipped with the correct fittings and components as detailed in **Figure 7-1** and **Table 7-1**.

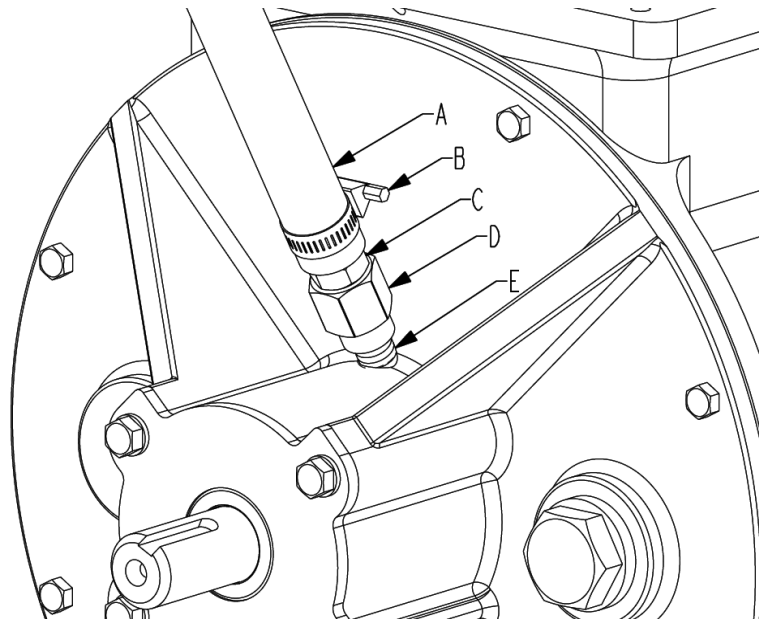

Figure 7-1: Purge system set-up

Table 7-1: Purge system components

Figure 7-1 Reference	Description	Walinga Part Number
A	3/4" AIR TUBE, RED	73-103315-6
B	9/16" - 1-1/4" GEAR CLAMP	28-00578-6
C	3/4" HOSE BARB, 1/2" NPT	81-18800-6
D	1/2" - 3/8" NPT REDUCER	81-13352-6
E	3/8" NPT NIPPLE	81-01897-6

2. Ensure the supply lines are connected immediately after the blower outlet and before the muffler (if present) and are approximately equal in length.
3. Loosen the gear clamps and remove the airline from the barb fittings.
4. Examine the interior of the airline and fittings.
 - a. If either have excessive build-up, low levels of dust is acceptable, there is insufficient air pressure and/or volume entering the cavity.
 - b. Check to ensure there are no obstructions in the airline. Clear any obstructions.
 - c. If necessary, install a properly sized airline to achieve sufficient air supply.
5. Ensure all fittings are tight and reinstall the airline, securing in place with the gear clamps.
6. Monitor and check the purge airline for accumulations to ensure the system is functioning properly.

Inlet Wiper Blade

Efficient operation of the airlock requires a close fit between the tips of the rotor and the casing to maintain a seal between the pressure differential of the inlet and outlet sides of the airlock. The airlock wiper blade is located at the top left side of the inlet. It functions to level the material for each rotor pocket as it moves out of the inlet area and into the casing. This ensures even flow, reduced wear rates, avoidance of 'out-of-round' wear within the casing, prevention of overfilling of each pocket, and reduces damage to both the blade tips and the conveyed material.

To check the condition of the wiper blade, proceed as follows:

1. Clear the area of bystanders, especially small children.
2. Place all controls in neutral, stop and lock-out the power source, and wait for all moving parts to stop.
3. Gain access to the airlock inlet by opening an installed access point or removing a portion of the inlet structure. Refer to the auxiliary equipment's operator's manual to determine the correct method of access to the airlock inlet.
4. Reach into the top of the airlock and check the overlap of the wiper blade with each tip. Polymer wiper blades should contact each tip approximately 1/16 in (1.5 mm), solid wiper blades should have a clearance of 0.030 in to 0.060 in (0.76 mm to 1.5 mm). Reposition the wiper blade using the mounting slots to adjust the overlap or clearance as necessary.

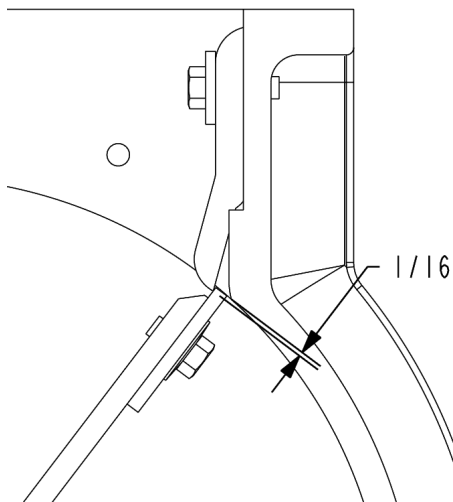

Figure 7-2: Polymer wiper overlap

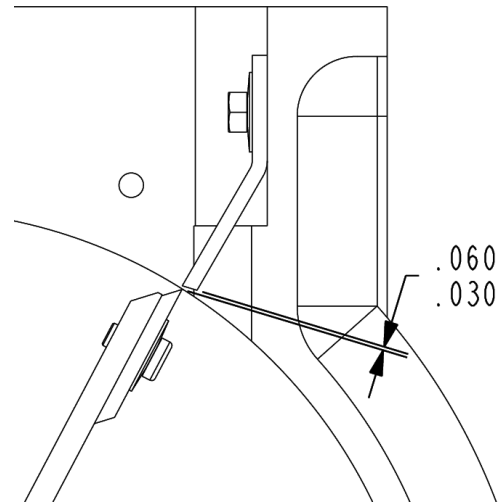

Figure 7-3: Solid wiper clearance

5. Inspect the condition of the wiper blade. Look for any signs of nicks, tears, significant pitting, wear or other damage. Replace the blade if it is damaged in any way.

To replace the wiper blade, proceed as follows:

1. Clear the area of bystanders, especially small children.
2. Place all controls in neutral, stop and lock-out the power source, and wait for all moving parts to stop.
3. Gain access to the airlock inlet by opening an installed access or removing a portion of the inlet structure. Refer to auxiliary equipment's operator's manual to determine the correct method of access to the airlock inlet.
4. Loosen and remove the hardware securing the wiper blade to the inlet including bolts and washers/washer plates.

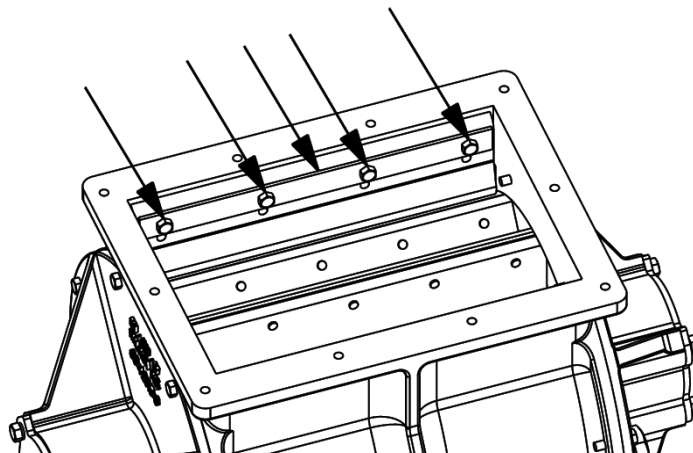

Figure 7-4: Removal of mounting hardware

5. Remove the old wiper blade from the airlock.
6. Insert the new wiper blade into the airlock and loosely install the mounting hardware.
7. Adjust the position of the wiper blade to achieve the correct position in relation to the tips. Polymer wiper blades should overlap the tips approximately 1/16 in (1.5 mm). Solid wiper blades must have a minimum clearance of 0.030 in (0.76 mm) and a maximum clearance of 0.060 in (1.5 mm), check the clearance using a feeler gauge. Reference **Figure 7-2** and **Figure 7-3**.
8. Once positioned correctly, tighten the mounting hardware to secure in position, refer to **Section 8: Specifications** for the correct torque.
9. Reinstall and/or close any auxiliary components removed and/or opened to gain access to the airlock inlet and secure all guards in place.

Rotor Shaft Bearing Grease Packing

To maintain smooth rotation of the airlock rotor, the rotor shaft bearing must remain properly lubricated. For abrasive style airlocks, it is important that the shaft bearing is repacked with grease after the first 200 hours of operation. For all other styles of airlocks, the bearings should be repacked with grease as required to reduce wear, protect against corrosion, aid in evacuation of debris, and maintain thermal balance. During operation, monitor the sound of the bearing and take note of any changes or abnormal sounds as this may indicate bearing wear or damage.

To repack the bearing, proceed as follows:

1. Clear the area of bystanders, especially small children.
2. Place all controls in neutral, stop and lock-out the power source, and wait for all moving parts to stop.
3. Remove the fasteners securing the seal plate in place and remove the seal plate.

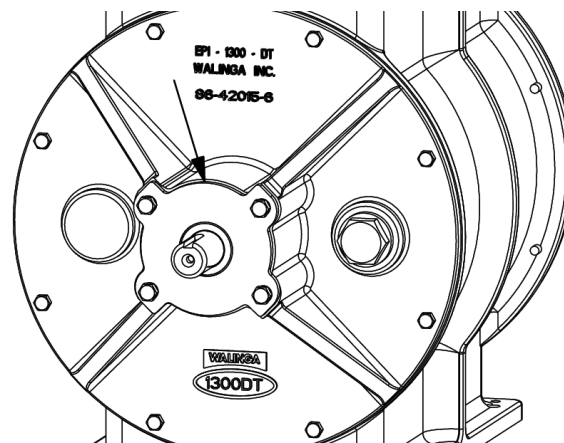

Figure 7-5: Removal of seal plate

- Loosen and remove the set screw from the lock nut and the lock nut from the rotor shaft.

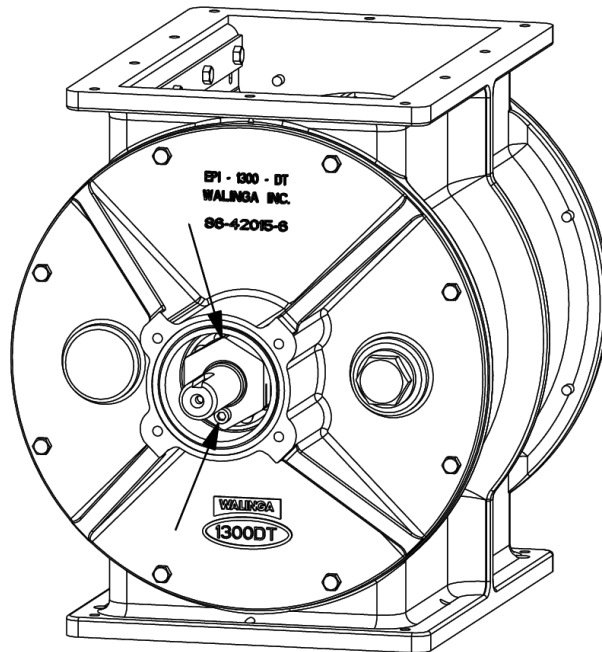

Figure 7-6: Removal of set screw and lock nut

- Loosen and remove the fasteners securing the end plate to the casing.

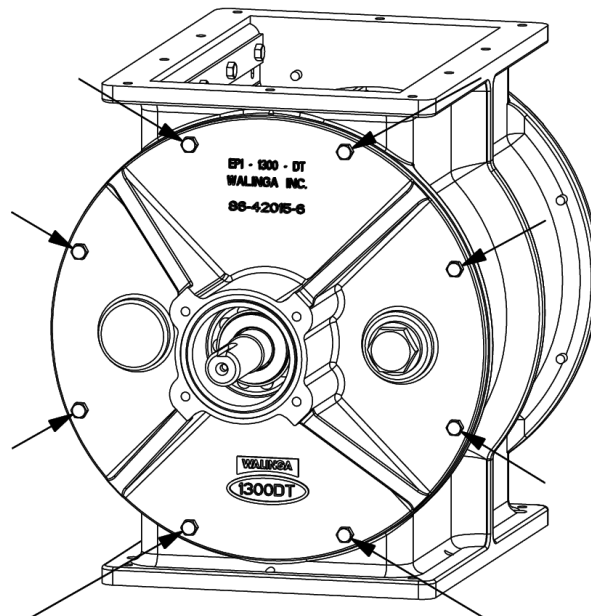

Figure 7-7: Removal of end plate fasteners

6. Remove the end plate and provide a support to the rotor shaft to prevent unnecessary strain on the opposite end plate and bearing.

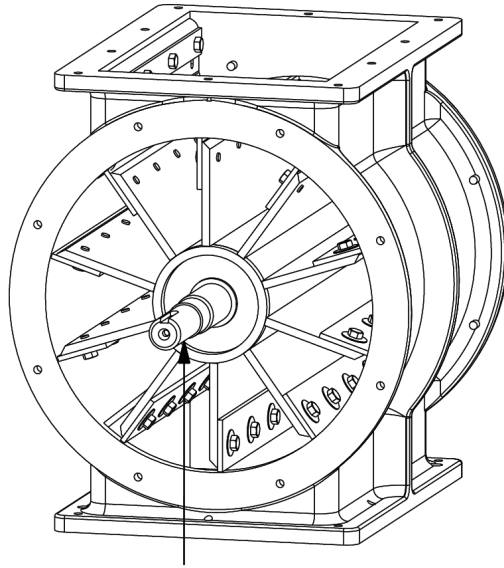

Figure 7-8: Removal of end plate and shaft support

7. Remove the bearing cone assembly from the bearing cup. Use care and caution when using tools to prevent damage to the bearing cup and cone.

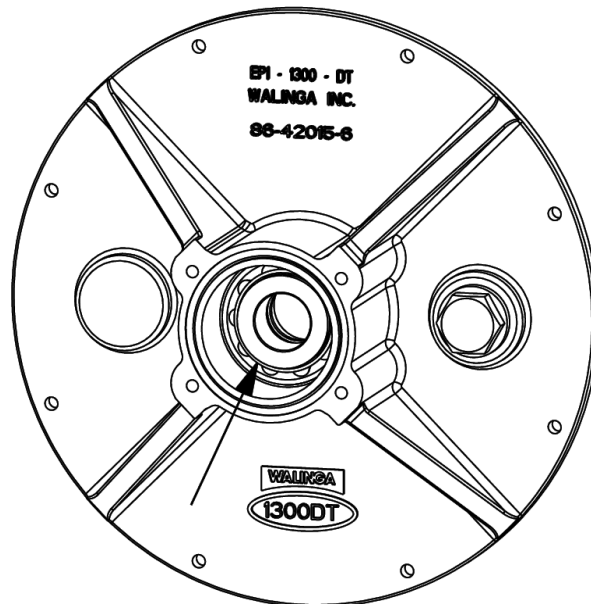

Figure 7-9: Removal of bearing cone assembly

8. Inspect the inner surface of the bearing cup for signs of excessive wear or heat, flaking, fretting, cracking or chipping, brinelling or nicks, and scuffing or scratching. If the cup is damaged in any way, the entire bearing assembly must be replaced.
9. Inspect the bearing cone for signs of excessive wear or heat, flaking, fretting, cracking or chipping, brinelling or nicks, and scuffing or scratching. If the cone is damaged in any way, the entire bearing assembly must be replaced.
10. If necessary, clean the bearing cup and cone with a non-residual solvent to remove any contaminants.
11. Thoroughly clean your hands or wear a pair of new latex gloves.
12. Place the required amount of grease into the palm of the hand. The standard tapered bearings in most airlock models require approximately 0.67 in³ (10.8 cm³) of grease.
13. Using the other hand, push the large diameter end of the bearing cone assembly into the grease to force the grease between the rollers, cage and cone.

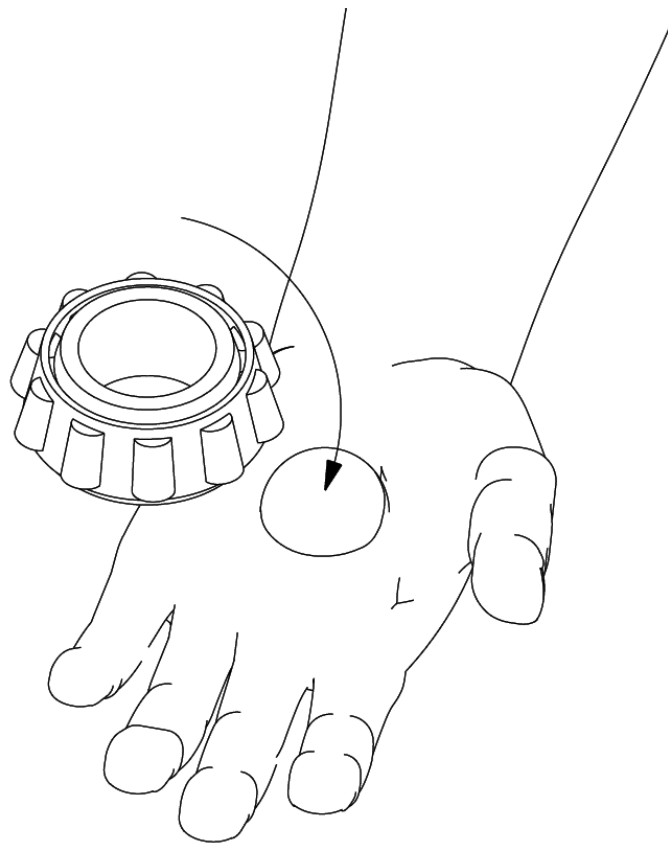

Figure 7-10: Forcing grease into bearing cone assembly

14. Rotate the bearing cone assembly slightly and repeat **Step 12** around the entire circumference of the assembly until the grease is evenly forced out of the small diameter end of the assembly.

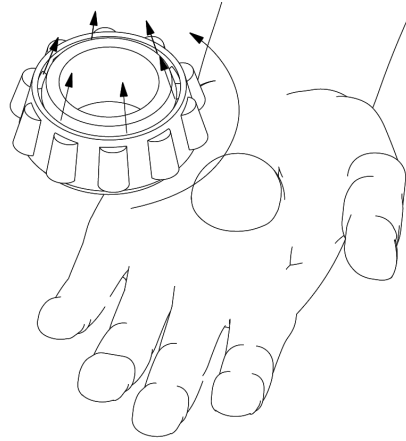

Figure 7-11: Packing bearing cone assembly with grease

15. Smear the extruded and excess grease around the outer surface of the bearing cone assembly.
16. Ensure the bearing cup is properly seated against the shoulder of the end plate. Never use the bearing cone to drive the bearing cup into position; this can damage the bearings and cause premature failure.

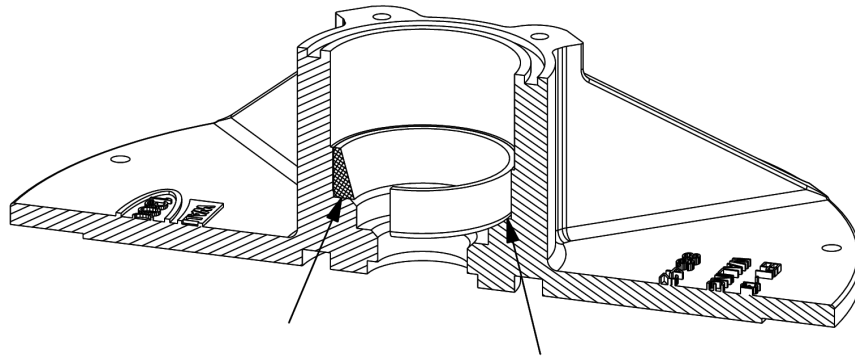

Figure 7-12: Proper installation of bearing cup

17. Position the end plate against the casing and secure in place with the required fasteners, reference **Figure 7-7**. Tighten to the torque specified in **Section 8: Specifications**.
18. Reinstall the bearing cone assembly into the bearing cup, reference **Figure 7-9**. Use care and caution when using tools to prevent damage to the bearing cup and cone.
19. Install the lock nut onto the shaft, reference **Figure 7-6**, and tighten to the required torque as specified in **Section 8: Specifications**.

20. Install the set screw into the lock nut, reference **Figure 7-6**, and tighten to the required torque as specified in **Section 8: Specifications**.
21. Rotate the rotor assembly by hand to ensure it rotates smoothly and there are no abnormal sounds from the bearing assembly such as crunching or grinding.
22. Install the seal plate, reference **Figure 7-5**, and tighten the seal plate fasteners to the required torque as specified in **Section 8: Specifications**.
23. Repeat **Step 3** to **Step 22** for the other end plate and bearing.
24. Refer to the section *Rotor and Blade Tip Clearances* to ensure the rotor is properly positioned with the correct clearances.
25. Ensure all guards have been installed and secured before operation of the airlock.

Bearing and Seal Cavity Inspection

To reduce damage and wear to the bearing, it is important that the bearing cavity is kept clean and free of dirt, dust and debris. When conveying products with abrasive properties or high levels of dust, it is possible for some contaminants to enter the bearing cavity, even when abrasive style airlocks are equipped with a purge line.

To check the condition of the bearing cavity, proceed as follows:

1. Clear the area of bystanders, especially small children.
2. Place all controls in neutral, stop and lock-out the power source, and wait for all moving parts to stop.
3. Remove the fasteners securing the seal plate in place and remove the seal plate, reference **Figure 7-5**.
4. Inspect the inner surfaces of the cavity for dirt, dust or debris.

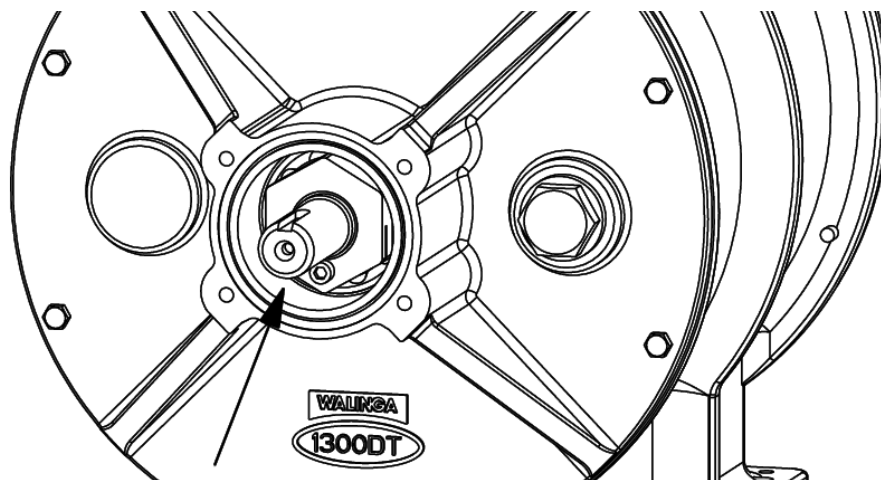

Figure 7-13: Bearing cavity

5. If there are excessive levels of dirt, dust or debris in the cavity, the seal(s) must be replaced. To replace the inner seal(s), proceed as follows:
 - a. Loosen and remove the lock nut and set screw from the rotor shaft. Reference **Figure 7-6**.
 - b. Loosen and remove the fasteners securing the end plate to the casing. Reference **Figure 7-7**.
 - c. Carefully remove the end plate from the airlock and support the rotor shaft. Reference **Figure 7-8**.
 - d. Remove the bearing cone assembly. If necessary, remove the bearing cup. Reference **Figure 7-9**.
 - e. Remove the old seal(s) from the end plate.

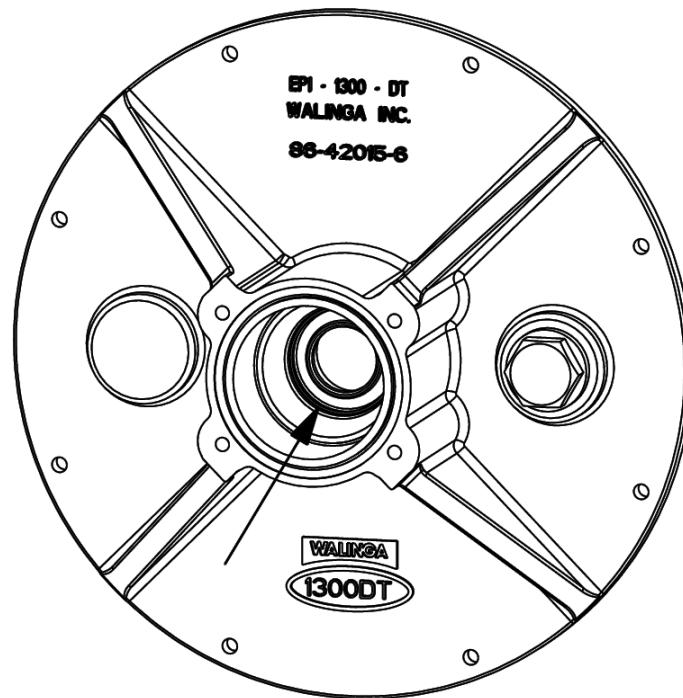

Figure 7-14: Removal of seal(s)

- f. Install the new shaft seal(s) into the end plate, refer **Section 11: Parts List** to identify the required seal. For abrasive style airlocks, the face of the first seal should be flush with the inner face of the end plate, for all other airlock styles, the face of the seal should rest against the inner shoulder of the end plate.

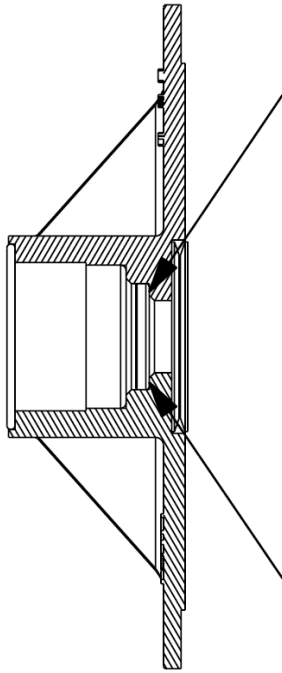

Figure 7-15: Standard airlock seal

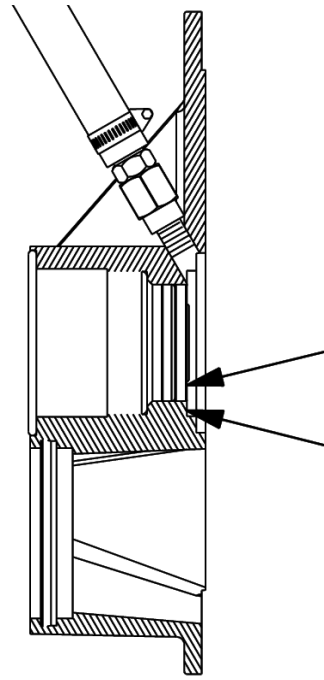

Figure 7-16: Abrasive style seals

- g. If equipped, check the condition of the “V” seal and seal plate O-ring seal for any signs of damage, wear, nicks or abrasion. Replace if necessary with reference to **Section 11: Parts List**.

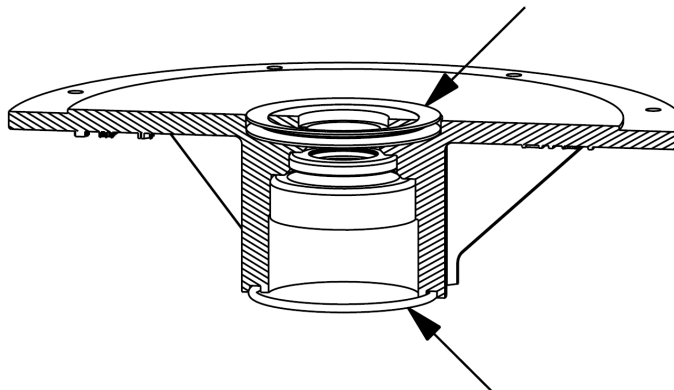

Figure 7-17: “V” seal and O-ring

6. If necessary, repack the bearing with grease, refer to **Step 8** to **Step 15** of the above section *Rotor Shaft Bearing Grease Packing*.
7. If necessary, refer to **Section 11: Parts List** to identify the correct replacement for the seal plate if it shows any signs of damage or wear, and replace the seal plate.
8. Reinstall all components that were removed with reference to **Step 16** to **Step 22** of the above section *Rotor Shaft Bearing Grease Packing*.
9. Repeat **Step 3** to **Step 8** for the other end plate.
10. Refer to the section *Rotor and Blade Tip Clearances* to ensure the rotor is properly positioned with the correct clearances.
11. Ensure all guards have been installed and secured before operation of the airlock.

Torquing of Bolts and Fasteners

To ensure all components are properly positioned, secured, sealed, and that the assembled airlock will function properly, the fasteners used to assemble the airlock must meet the required torque specifications. It is possible that some fasteners may loosen slightly during operation, so it is important to retorque the fasteners to maintain full functionality and preserve the safety of the airlock. Refer to **Section 8: Specifications** for the required torque for each fastener.

Rotor and Blade Tip Clearances

To maintain the seal between the inlet and outlet and efficient operation, the airlock requires a close fit between the tips of the rotors and the casing. Excessive clearance allows 'blow-back' of air from the discharge to the inlet of the airlock leading to uneven flow and reduced performance. Routine maintenance of tip clearances is especially important when conveying materials with high abrasion characteristics and may need to be performed more often if it is noted that the tips consistently exceed the maximum clearance at the recommended maintenance interval.

To check the tip clearances, proceed as follows:

1. Clear the area of bystanders, especially small children.
2. Place all controls in neutral, stop and lock-out the power source, and wait for all moving parts to stop.
3. Gain access to the airlock inlet by opening an installed access point or removing a portion of the inlet structure. Refer to the auxiliary equipment's operator's manual to determine the correct method of access to the airlock inlet.

4. Rotate the rotor by hand to inspect the condition of each blade, looking for any that are bent, chipped, cracked, or otherwise broken. Replace any damaged blades with reference to the section *Rotor Blade Tip Clearance Adjustment*. **Note:** if only one edge of the tip is minimally damaged, it may be possible to use the other edge. Stainless steel tips may be reground to a 'true' edge; this may be repeated until there is no longer sufficient adjustment in the screw slots. Badly damaged tips **must** be replaced.
5. Use a feeler gauge to check the clearance between the tip and casing along the blade's entire length. Measure the clearance with reference to the casing edge opposite to the wiper blade, as shown in **Figure 7-18** (the casing edge on the side of the wiper blade experiences greater levels of normal operational wear, meaning measurements taken in reference to this edge may result in clearances lower than the minimum allowable clearance, resulting in scraping or damage between the tips and casing). Reference **Table 7-2** for tip clearance requirements. Rotate the rotor by hand and repeat the clearance measurement for each tip.

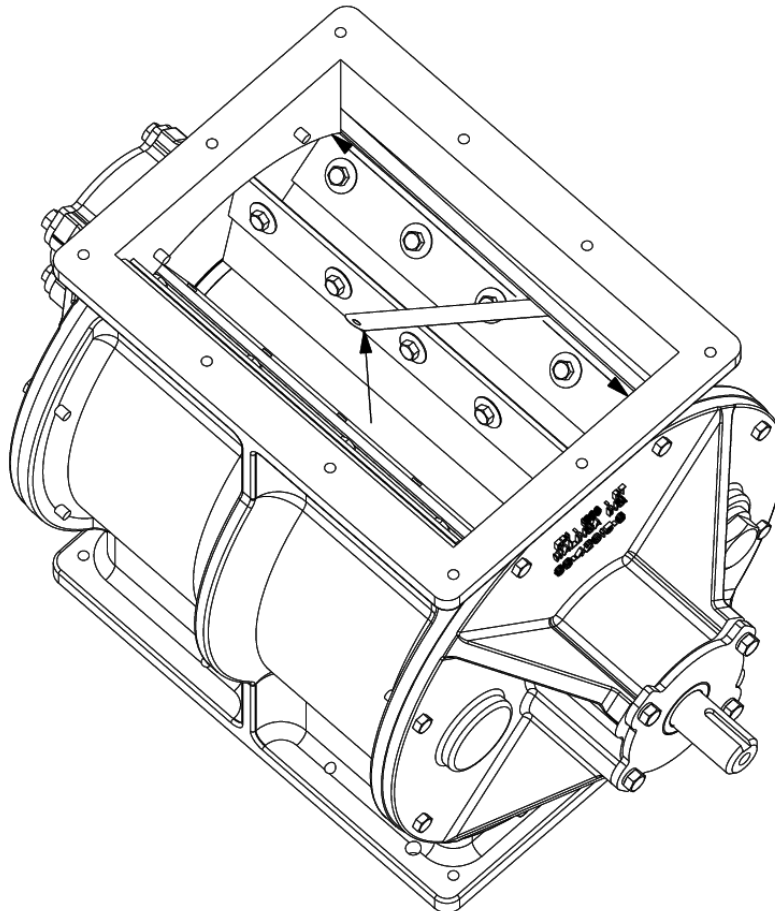

Figure 7-18: Inlet/top tip clearance

6. Blow-thru models have a different clearance requirement for the inlet and outlet side of the airlock, measurements for the 'bottom' should be taken from the outlet, as seen in **Figure 7-19**. Reference **Table 7-2** for tip clearance requirements. Rotate the rotor by hand and repeat the clearance measurement for each tip.

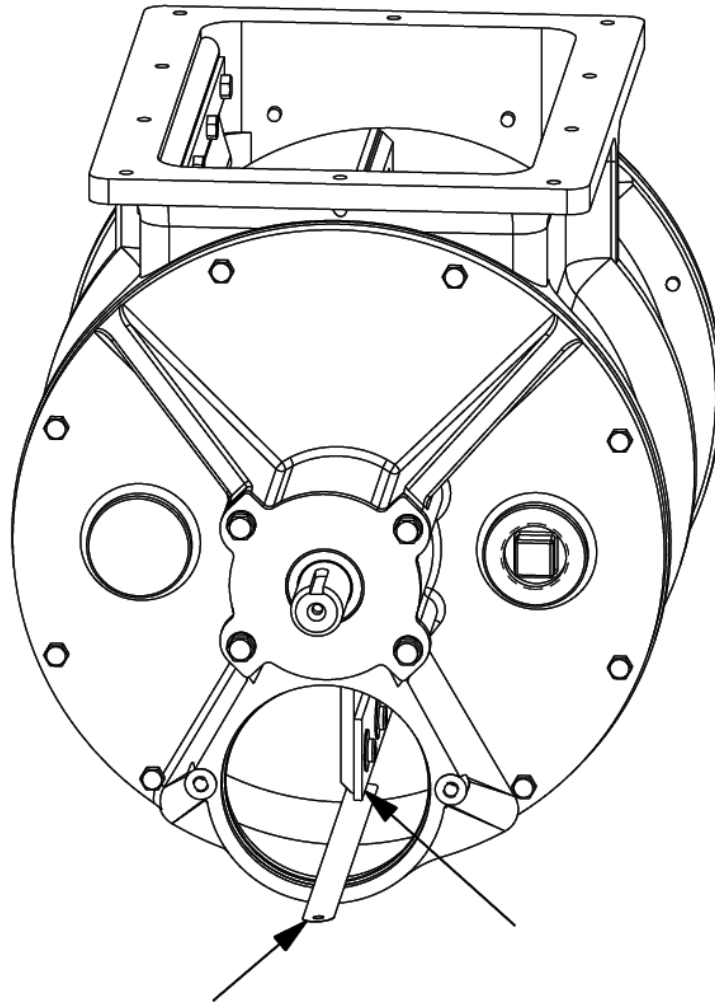

Figure 7-19: Outlet/bottom tip clearance

7. If the clearance between the tip and the casing exceeds the maximum clearance, it must be adjusted or replaced. Refer to section *Rotor Blade Tip Adjustment* to adjust or replace the tip.

Table 7-2: Rotor blade tip and casing clearance

Airlock		Minimum Clearance		Maximum Clearance
Model	Style			
1008	Drop-Thru	0.003 in (0.08 mm)		0.006 in (0.15 mm)
1210	Drop-Thru	0.004 in (0.10 mm)		0.007 in (0.18 mm)
1314	Drop-Thru	0.004 in (0.10 mm)		0.007 in (0.18 mm)
	Blow-Thru	Top	0.005 in (0.13 mm)	0.007 in (0.18 mm)
		Bottom	0.004 in (0.10 mm)	
1618	Drop-Thru	0.004 in (0.10 mm)		0.008 in (.020 mm)
	Blow-Thru	Top	0.006 in (0.15 mm)	0.008 in (0.20 mm)
		Bottom	0.004 in (0.10 mm)	
2018	Blow-Thru	Top	0.008 in (0.20 mm)	0.010 in (0.25 mm)
		Bottom	0.005 in (0.13 mm)	
2224	Drop-Thru	0.006 in (0.15 mm)		0.010 in (0.25 mm)
	Blow-Thru	Top	0.009 in (0.23 mm)	0.011 in (0.28 mm)
		Bottom	0.006 in (0.15 mm)	

To check the rotor clearances, proceed as follows:

1. Clear the area of bystanders, especially small children.
2. Place all controls in neutral, stop and lock-out the power source, and wait for all moving parts to stop.
3. Gain access to the airlock inlet by opening an installed access point or removing a portion of the inlet structure. Refer to the auxiliary equipment's operator's manual to determine the correct method of access to the airlock inlet.
4. Use a feeler gauge to check the clearance between the rotor and both end plates, as shown in **Figure 7-20**. Reference **Table 7-3** for clearance requirements. Rotate the rotor by hand to check the clearance of each rotor blade.

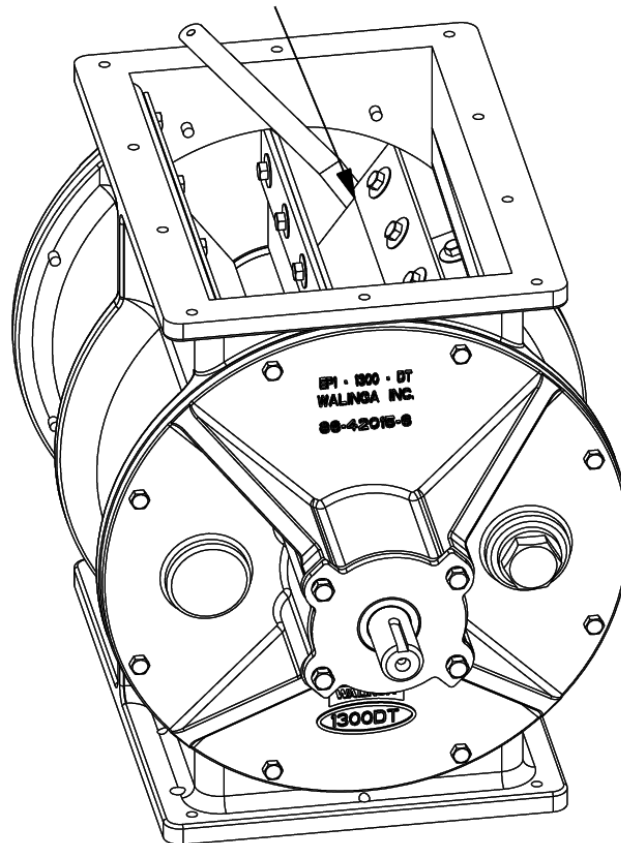

Figure 7-20: Rotor clearance

Table 7-3: Rotor and end plate clearance

Airlock		Minimum Clearance	Maximum Clearance
Model	Style		
1008	Drop-Thru	0.004 in (0.10 mm)	0.006 in (0.15 mm)
1210	Drop-Thru	0.005 in (0.13 mm)	0.007 in (0.18 mm)
1314	Drop-Thru	0.005 in (0.13 mm)	0.007 in (0.18 mm)
	Blow-Thru		
1618	Drop-Thru	0.007 in (0.18 mm)	0.009 in (0.23 mm)
	Blow-Thru		
2018	Blow-Thru	0.007 in (0.18 mm)	0.009 in (0.23 mm)
2224	Drop-Thru	0.010 in (0.25 mm)	0.013 in (0.33 mm)
	Blow-Thru	0.007 in (0.18 mm)	0.010 in (0.25 mm)

5. If the clearance between the rotor and end plate exceeds the maximum clearance, the airlock assembly must be replaced. Refer to **Section 4: Machine Life-Cycle Procedures** for end-of-life instructions.

Operating Temperature

To prolong component and airlock life, the airlock must not be operated at elevated temperatures for extended periods. Operation at elevated temperatures for extended periods can cause premature failure including seal failure, accelerated breakdown of internal bearing grease, and in extreme cases, contact between the rotor and casing resulting in gouging of the end plate or casing. High operating temperatures may be the result of hot products being conveyed through the airlock, high blower temperatures as a result of a high pressure-vacuum differential, high levels of friction in moving airlock components, or rubbing between the rotor and casing or end plate. Refer to **Table 7-4** for the maximum airlock operating temperatures.

Table 7-4: Maximum operating temperatures

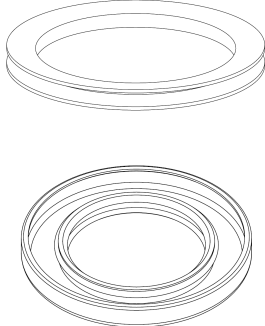
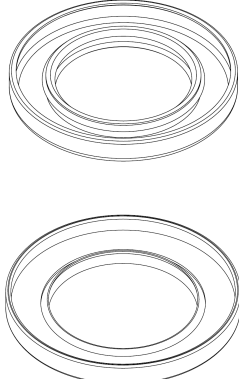
Airlock Style	Seal Style		Maximum Temperature
Standard	"V" seal and "CR" seal		140 °F [60 °C]
Abrasive	"CR" seal and "AVT" seal		212 °F [100 °C]

To check the operating temperature, proceed as follows:

1. Clear the area of bystanders, especially small children.
2. Operate the airlock under normal operational conditions for a sufficient period of time to allow all components to stabilize at their operating temperature.
3. Measure the temperature of the following areas:
 - a. Rotor bearings
 - b. Drive motor
 - c. Airlock casing
4. Ensure the temperature of the areas do not exceed the maximum operational temperatures as detailed in **Table 7-4**.
5. If the temperatures exceed the maximum operational temperatures:
 - a. Address and correct the cause of the high temperatures.
 - b. Inspect the rotor seals, bearings, casing, and end plates for signs of damage or degradation.
 - c. Replace any worn or damaged components.

Airline Seals

To maintain the intended pressure/vacuum levels on each side of the airlock to achieve smooth and high capacity product conveyance, the airlines must be well sealed. Each joint in the airline of a pneumatic conveying system is equipped with a seal.

To check the condition of the airline seals, proceed as follows:

1. Clear the area of bystanders, especially small children.
2. During normal operation, monitor and inspect the airline joints of the airlock for any apparent leaks, listen for any hissing, whistling or other signs of leaking.
3. Check the condition of the inlet seal as follows:
 - a. With reference to the auxiliary equipment's operator's manual, remove any components connected to the airlock inlet.
 - b. Visually inspect the seal, looking for any nicks, tears, abraded areas, excessive wear, or accumulation of dirt, dust or debris.

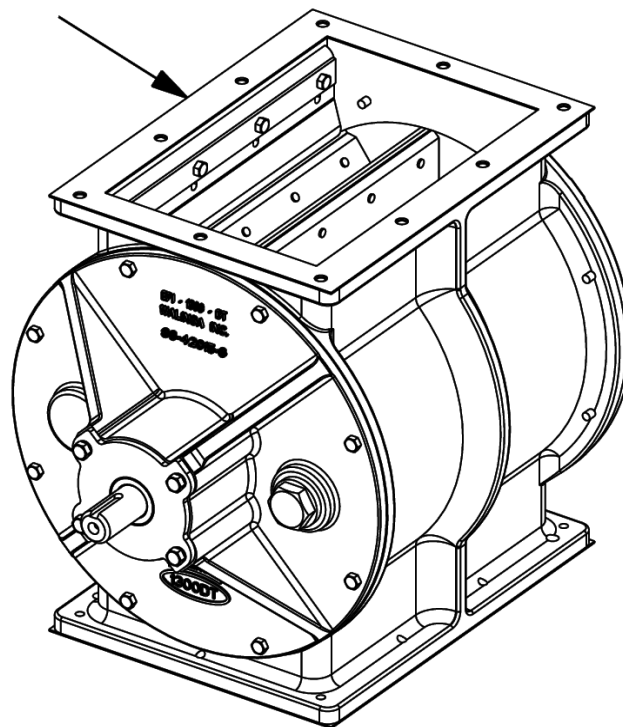

Figure 7-21: Inlet seal

- c. Clean or replace the seal as required.
- d. Reinstall any components that were removed and ensure all guards are installed and secured.

4. For drop-thru style airlocks, inspect the outlet seal as follows:
 - a. With reference to the auxiliary equipment's operator's manual, remove any components connected to the airlock outlet.
 - b. Visually inspect the seal, looking for any nicks, tears, abraded areas, excessive wear, or accumulation of dirt, dust or debris.

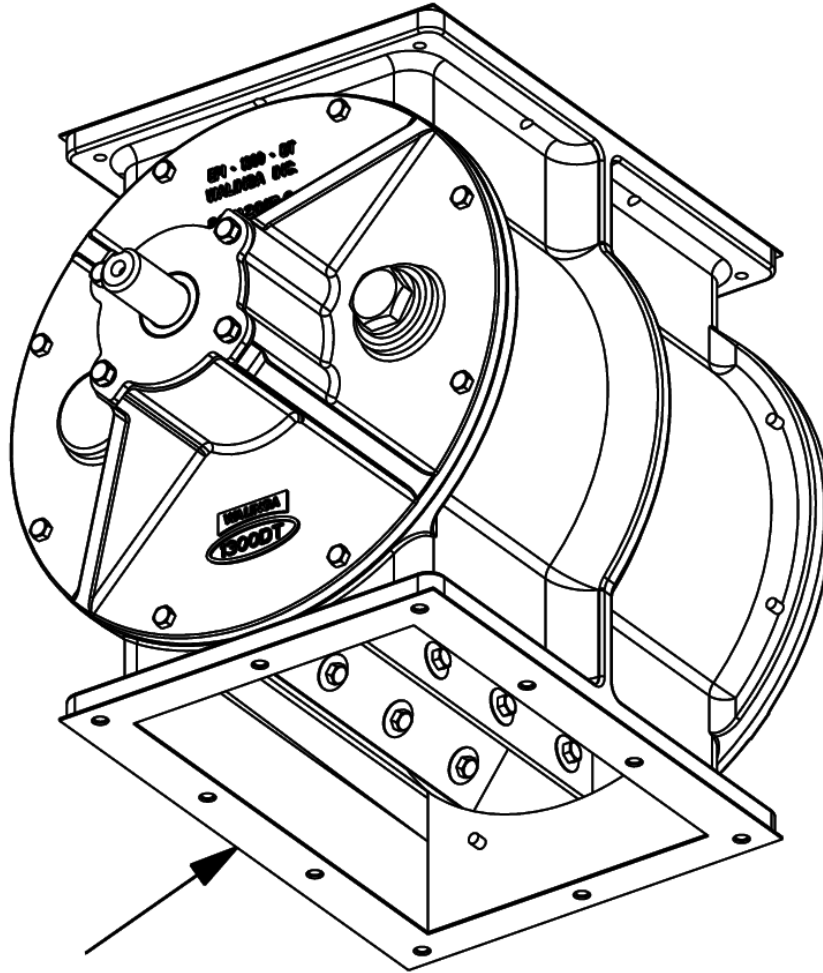

Figure 7-22: Drop-thru outlet seal

- c. Clean or replace the seal as required.
 - d. Reinstall any components that were removed and ensure all guards are installed and secured.
5. For blow-thru style airlocks, inspect the outlet seals as follows:
 - a. With reference to the auxiliary equipment's operator's manual, remove any components, including adapters and reducers, connected to the airlock outlet.

- b. Visually inspect the airlock outlet seals, looking for any nicks, tears, abraded areas, excessive wear, or accumulation of dirt, dust or debris.

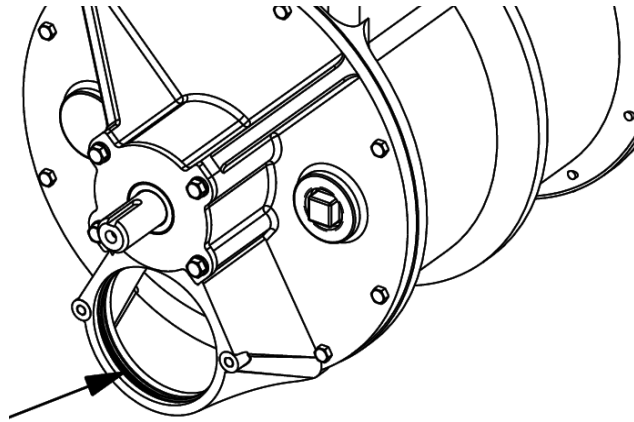

Figure 7-23: Blow-thru outlet seal

- c. Clean or replace the seal as required.
 - d. Visually inspect the seal of any removed adapters, reducers or couplers, looking for any nicks, tears, abraded areas, excessive wear, or accumulation of dirt, dust or debris.
 - e. Clean or replace the seal as required.
 - f. Reinstall any components that were removed and ensure all guards are installed and secured.
6. Inspect the rotor seals as follows:
 - a. Loosen and remove the fasteners securing the seal plates in place. Remove the seal plates.
 - b. Visually inspect the seal plate shaft seal, looking for any nicks, tears, abraded areas, excessive wear, or accumulation of dirt, dust or debris.

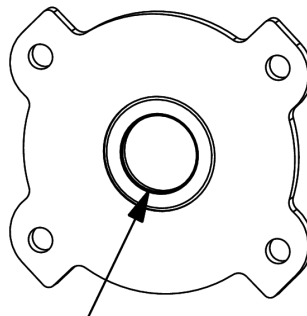

Figure 7-24: Driven-end seal plate shaft seal

- c. Clean or replace the seal as required.
- d. Visually inspect the end plate-seal plate seals, looking for any nicks, tears, abraded areas, excessive wear, or accumulation of dirt, dust or debris.

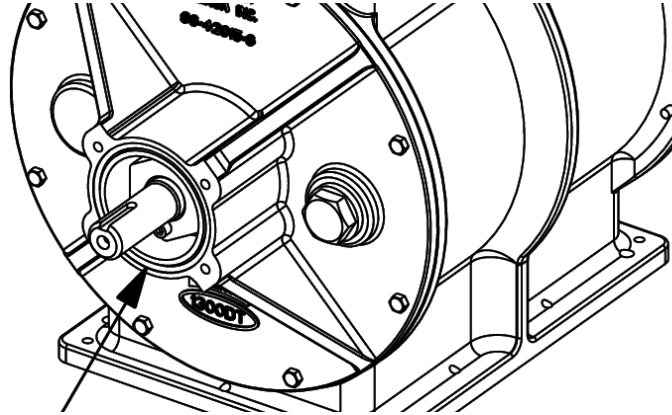

Figure 7-25: Inner seal plate seal

- e. Clean or replace the seals as required.
- f. Loosen and remove the lock nut, set screw, and bearing cone and cup as required.
- g. Visually inspect the inner rotor shaft seals, looking for any nicks, tears, abraded areas, excessive wear, signs of thermal degradation, or accumulation of dirt, dust or debris.

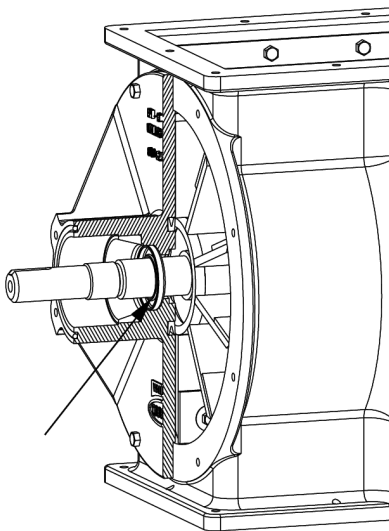

Figure 7-26: Standard style inner shaft seal

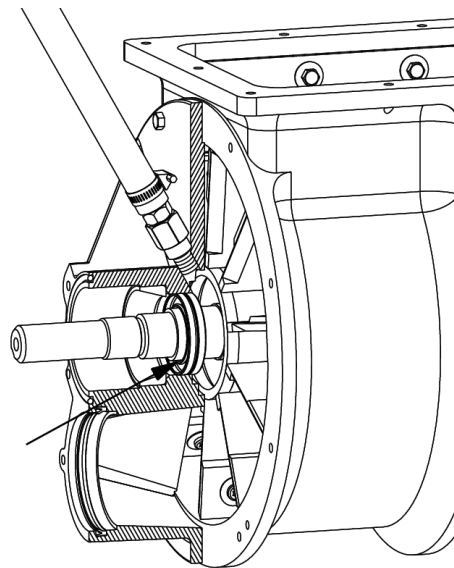

Figure 7-27: Abrasive style inner shaft seals

- h. Clean or replace the seals as required.
- i. For standard style airlocks, loosen and remove the fasteners securing the end plate in place and remove the end plate.
- j. Visually inspect the "V" seals, looking for any nicks, tears, abraded areas, excessive wear, signs of thermal degradation, or accumulation of dirt, dust or debris.

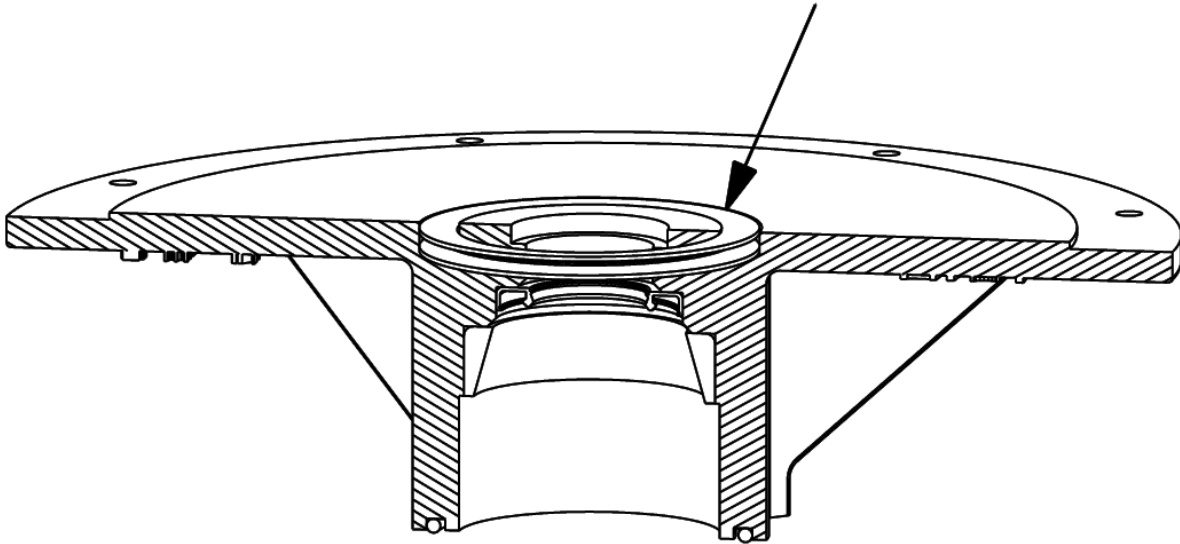

Figure 7-28: End plate "V" seal

- k. Clean or replace the seals as required.
- l. Reinstall all end plate and rotor components with reference to the section *Rotor Shaft Bearing Grease Packing* **Step 16** to **Step 22**.
- m. Repeat **Step 6a** through **Step 6l** for the other end of the rotor.
- n. Reinstall any components that were removed and ensure all guards are installed and secured.

Rotor Blade Tip Clearance Adjustment

To maintain the seal between the inlet and outlet and efficient operation, the airlock requires a close fit between the tips of the rotors and the casing. As the tips wear during operation, they must be adjusted or replaced to maintain the required clearances.

To adjust the clearance of the blade tips, proceed as follows:

1. Clear the area of bystanders, especially small children.
2. Place all controls in neutral, stop and lock-out the power source, and wait for all moving parts to stop.
3. Gain access to the airlock inlet by opening an installed access point or removing a portion of the inlet structure. Refer to the auxiliary equipment's operator's manual to determine the correct method of access to the airlock inlet.
4. Place an identifying number on the leading side of the first blade to ensure no tips are missed during the process.

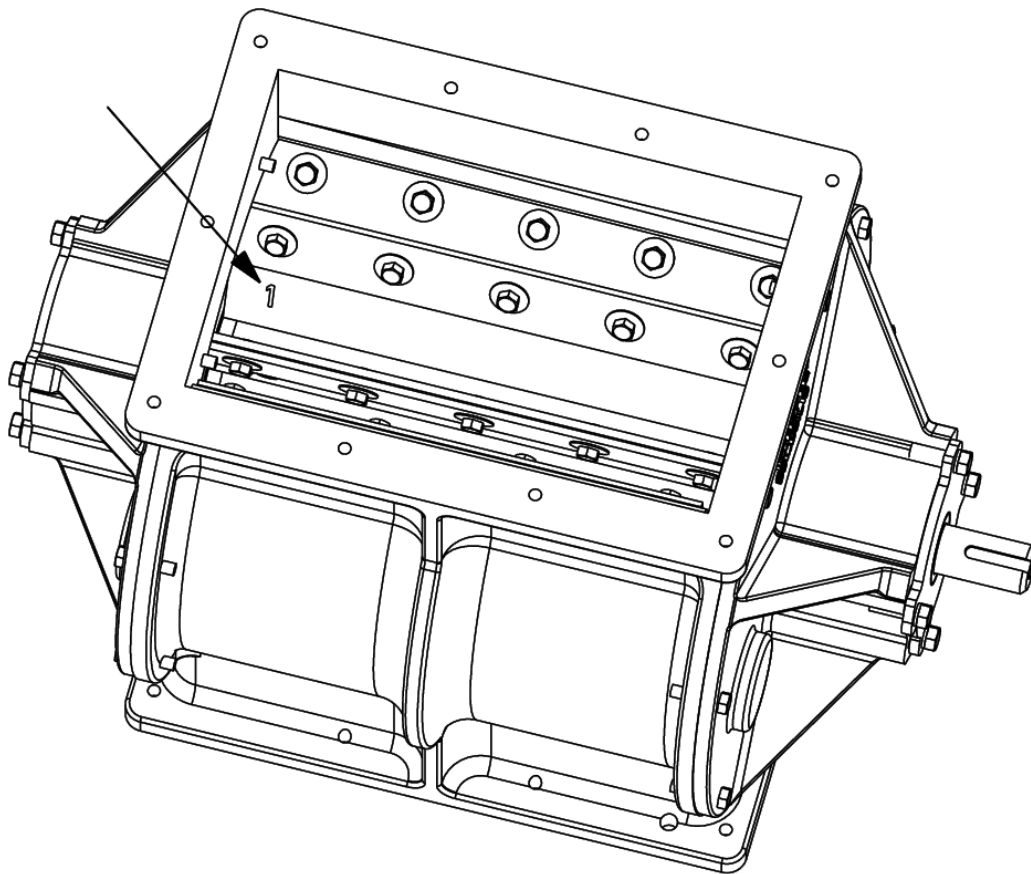

Figure 7-29: Identification of blades

5. Loosen the retaining fasteners holding the tip on the blade, but do not fully remove the screws.

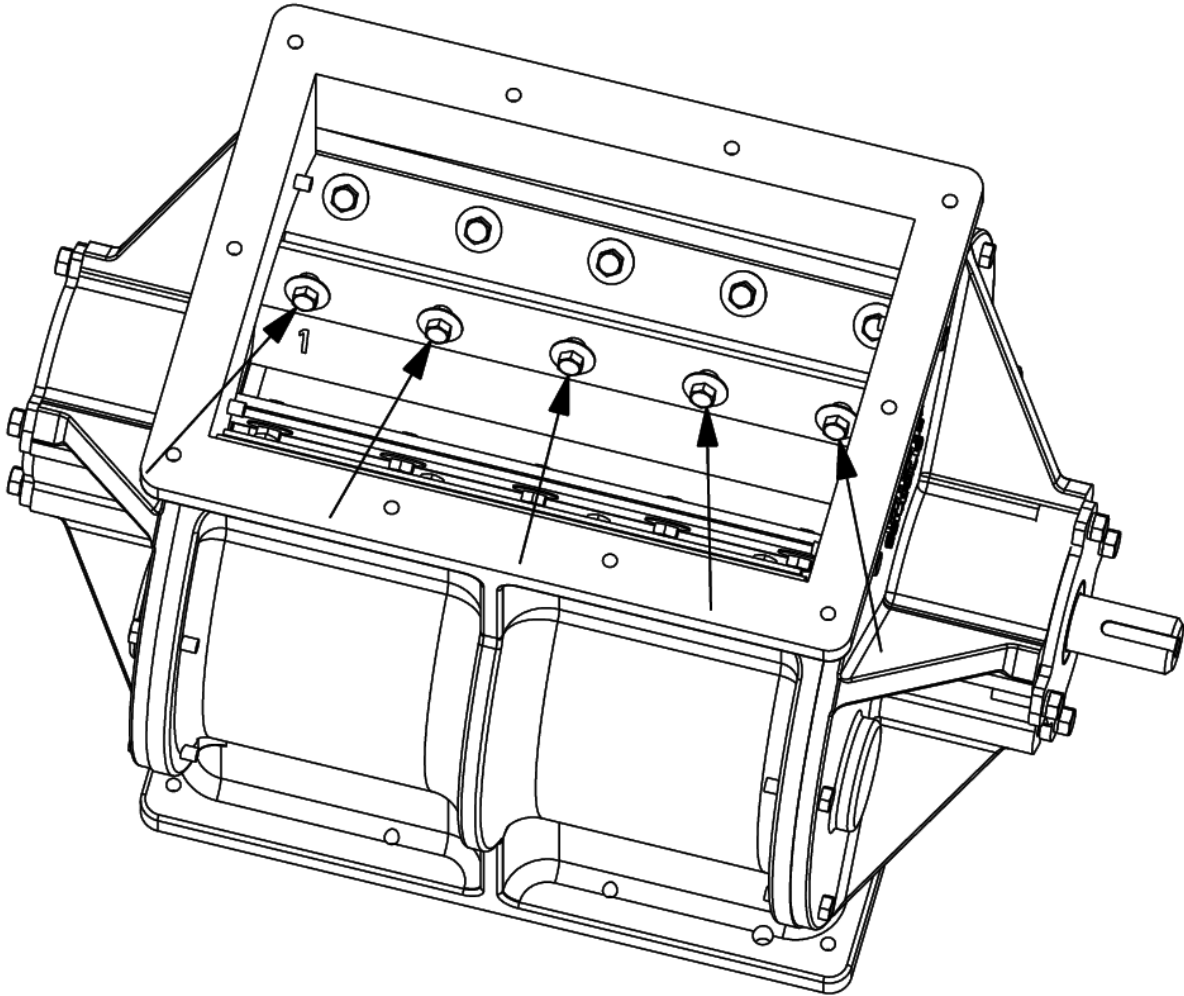

Figure 7-30: Tip fasteners

6. Rotate the rotor assembly until the loosened tip is approximately 1 in (25 mm) inside the casing on the side opposite to the wiper blade. The casing edge on the side of the wiper blade experiences greater levels of normal operational wear, meaning adjustments made in reference to this edge may result in clearances lower than the minimum allowable clearance, resulting in scraping or damage between the tips and casing.

Note: the blades are slightly angled in relation to the edge of the casing, so one end will be further inside than the other.

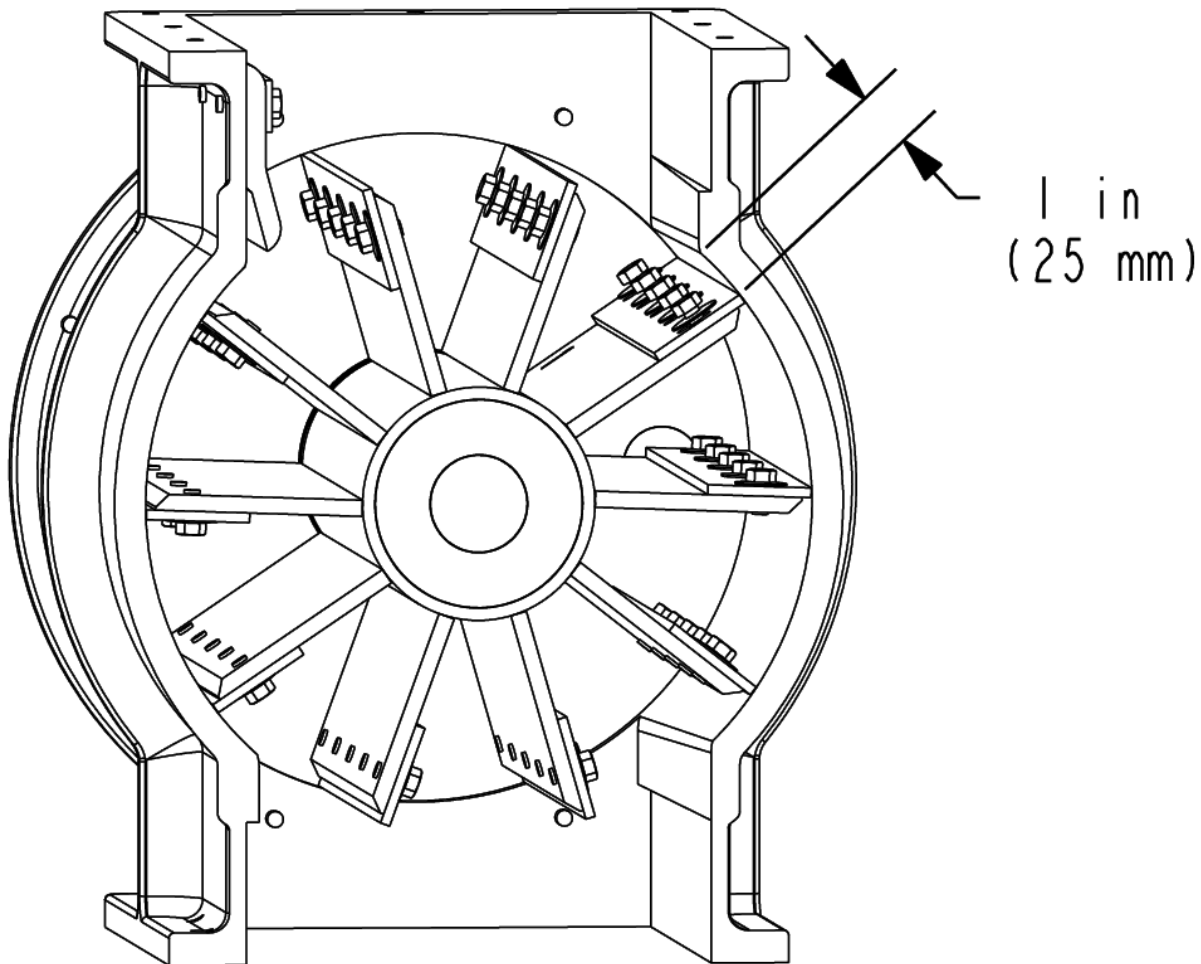

Figure 7-31: Tip positioning in casing

- Place the appropriate feeler gauge, with reference to **Table 7-2**, between the tip and the casing 4 in (10 cm) from one end of the blade tip, place a second feeler gauge of the same size 4 in (10 cm) between the tip and the casing at the other end of the tip.

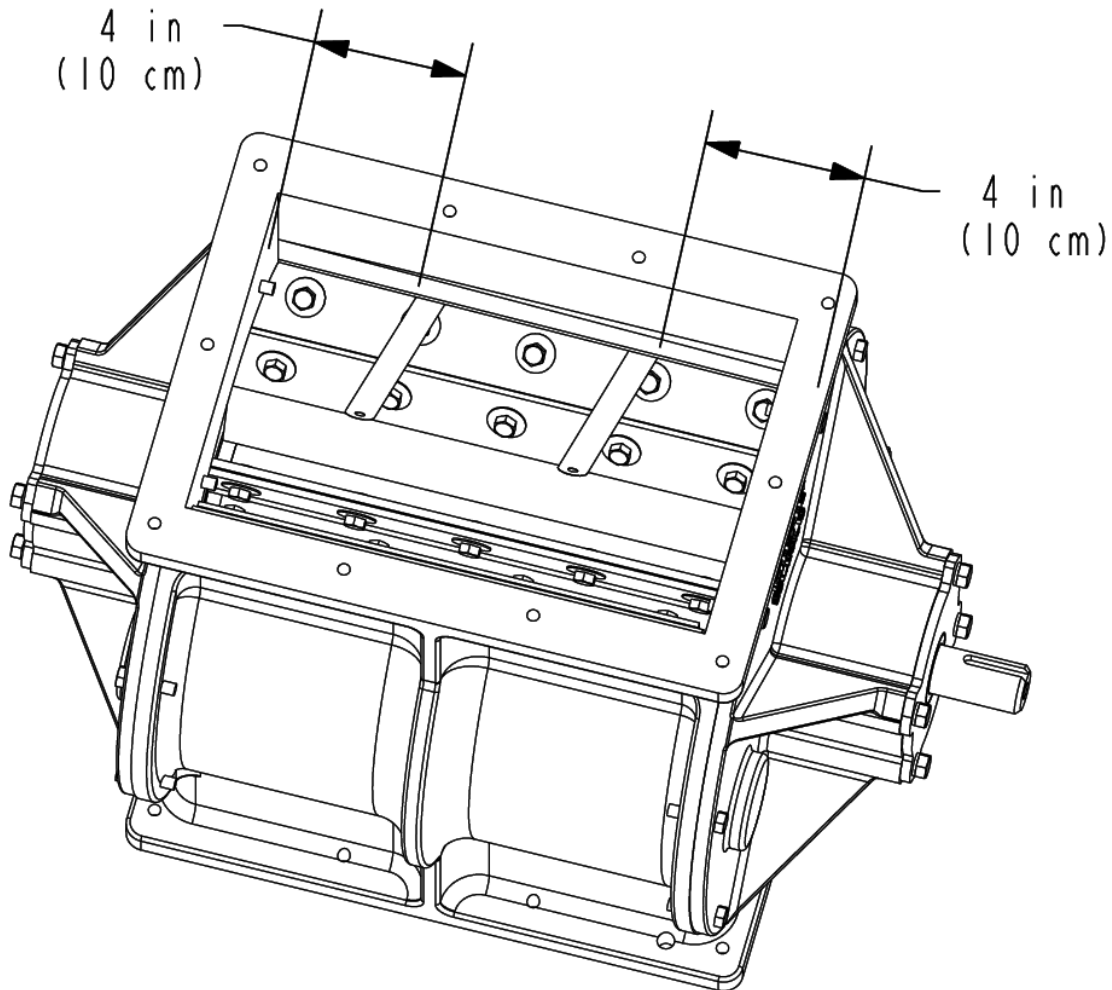

Figure 7-32: Feeler gauge placement

- Gently lever the tip upwards until it contacts both feeler gauges.

9. Tighten the tip retaining fasteners starting with the center fastener and moving outwards, alternating sides from the center to maintain the proper positioning until all fasteners have been tightened to the required torque as specified in **Section 8: Specifications**.

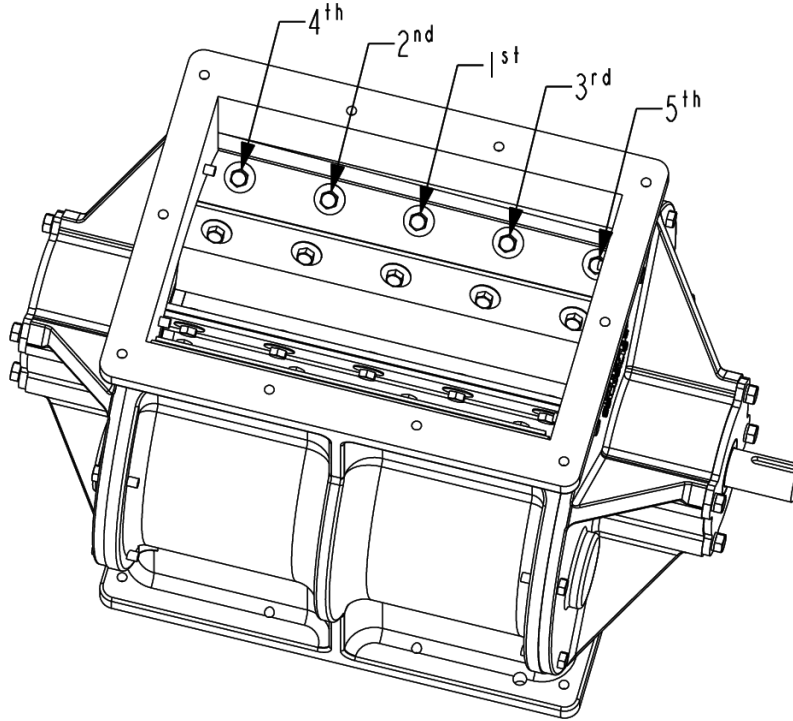

Figure 7-33: Reference fastener tightening order

10. By hand, rotate the rotor counter-clockwise, as viewed from the driven end, for one full revolution. Listen for any binding noise between the tip and casing; a light grinding noise is normal and should disappear as the tip seats fully during the first few hours of normal operation.
11. Repeat **Step 4** through **Step 10** for each blade until all tips have been adjusted. Check the identifying numbers marked in **Step 4** to ensure each tip has been adjusted.
12. Check the positioning of the wiper blade with each tip. Polymer wiper blades should contact each tip approximately 1/16 in (1.5 mm), and solid wiper blades should have a clearance of 0.030 in to 0.060 in (0.76 mm to 1.5 mm), reference **Figure 7-2** and **Figure 7-3**. If necessary, refer to the section *Inlet Wiper Blade* for adjustment or replacement instructions.
13. Reinstall or close any components that were removed or opened during adjustment and ensure all guards are in place and secured.

To replace a tip that has been damaged or has insufficient adjustment remaining in the mounting slots, proceed as follows:

1. Clear the area of bystanders, especially small children.
2. Place all controls in neutral, stop and lock-out the power source, and wait for all moving parts to stop.
3. Gain access to the airlock inlet by opening an installed access point or removing a portion of the inlet structure. Refer to the auxiliary equipment's operator's manual to determine the correct method of access to the airlock inlet.
4. Loosen and remove the fasteners securing the wiper blade and remove the wiper blade from the airlock for improved access.

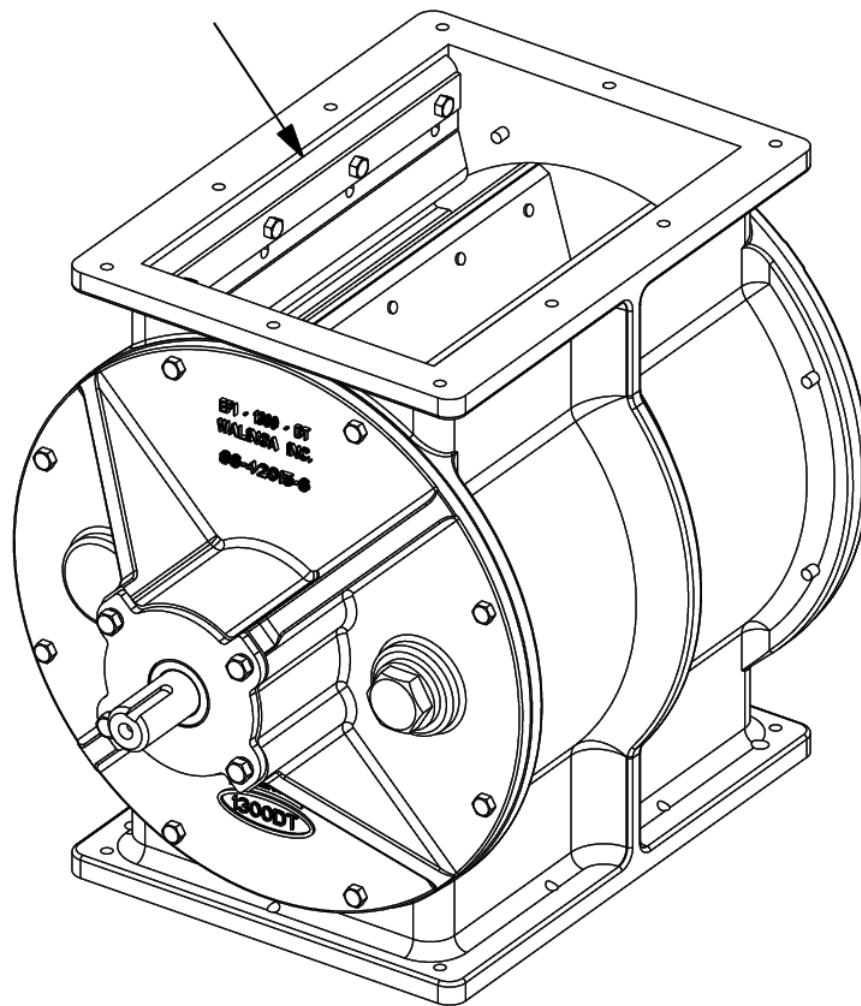

Figure 7-34: Removal of wiper blade

5. Loosen and remove the tip retaining fasteners and remove the first tip from the casing. It may be beneficial to gain access to the outlet of the airlock for easier removal of the tips.

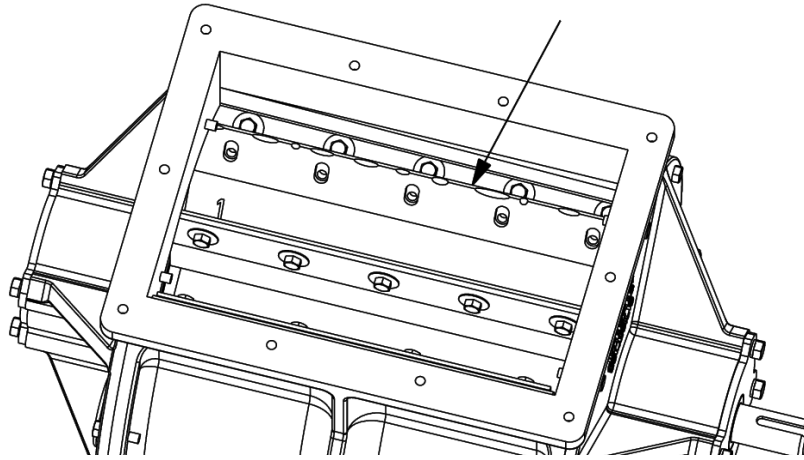

Figure 7-35: Removal of blade tip

6. Check the condition of the replacement tips. Ensure that none are bent and that all four edges are 'true' and undamaged.
7. Insert the new or reversed tip and loosely secure in place to measure the clearance between the tip and the end plates with reference to **Figure 7-20** and **Table 7-3**. If necessary, remove the tip from the blade and file to grind the ends of the tip to meet the minimum clearance requirements. Ensure the tip is not longer than the blade.
8. Loosely secure the tip to the blade with the required fasteners.
9. Follow **Step 4** through **Step 10** of the previous subsection for tip clearance adjustment.
10. Repeat **Step 4** through **Step 9** for each blade, ensuring each blade has been replaced and properly adjusted as required.
11. Refer to the section *Inlet Wiper Blade* for instructions on the reinstallation or replacement, and correct positioning of the wiper blade.
12. Clean the airlock thoroughly before conveying any product to ensure any potential contaminants or debris has been removed.
13. Reinstall or close any components that were removed or opened during installation and ensure all guards are in place and secured.
14. Run the airlock at operating speed without conveying any product, listening for any signs of binding or excessive grinding. A light grinding noise is normal and will disappear as the tips seat fully during the first few hours of normal operation. If the noise persists or is abnormal, return to **Step 6** above and proceed through the remaining steps to ensure the tips are undamaged and positioned with the correct clearances.
15. Ensure all components and guards are installed and secured.

MAINTENANCE MATERIALS

Grease

Use an SAE multi-purpose high temperature grease with extreme pressure (EP) characteristics. An SAE multi-purpose lithium-based grease is also acceptable. Walinga airlocks are manufactured using Unirex EP 2 (98-01959-6).

Thread Sealant

Use a high performance thread sealant for fittings, Permatex High Performance Thread Sealant (92-03141-6).

Lubricant Storage

An airlock can operate at top efficiency only if clean lubricants are used. Use clean containers to handle all lubricants, be aware of the static buildup/discharge characteristics of the storage containers. Store lubricants in a container and area protected from dust, moisture and other contaminants.

ADJUSTMENTS

Pressure-Vent Kit

Venting is not usually required when conveying materials with high bulk-densities such as cereal grains, however, some materials, such as milled meals or other light materials, may cause uneven flow or reduced performance due to air blow-back in the inlet area.

To determine if an airlock may benefit from a pressure-vent kit, perform the following test:

1. Operate the conveying system as normal, taking note of any uneven flow and the overall capacity/performance of the system.
2. Remove the vent plug from the end plate.
3. Operate the conveying system with the plug removed, taking note of any uneven flow and the overall capacity/performance of the system.

Caution: Both air and excess product may be discharged from the end plate vent during testing. **KEEP CLEAR** of the vent during testing.

4. Compare the product flow and overall capacity/performance of the system while the plug was in place to when the plug was removed. If the flow or performance improved with the plug removed, install a pressure-vent kit.

To install a pressure-vent kit, proceed as follows:

1. Clear the area of bystanders, especially small children.
2. Place all controls in neutral, stop and lock-out the power source, and wait for all moving parts to stop.
3. Ensure all required components, as detailed in **Table 7-5**, are ready and available.

Table 7-5: Pressure-vent kit components

Item	Description	Walinga Part Number	Quantity
A	A/L VENT PIPE ASSEMBLY	40-04944-5	1
B	FLEX HOSE, STAINLESS STEEL, 1 1/2" ID	36-03147-6	As Required
C	SADDLE CLAMP, PLTD, 1-3/4"	28-08133-6	As Required
D	STEEL TUBE, 1 1/2" OD	89-00291-1	As Required
E	A/L INLET ASSEMBLY	VARIOUS	1
F	RUBBER HOSE 5/8" ID	40-23043-4	1
G	GEAR CLAMP, 9/16" - 1-1/4", HS12	28-00578-6	2

4. Identify the end plate that will allow for the installation of the vent discharge line with the fewest number of bends, but allows for large radius bends to minimize flow restriction.
5. Remove the vent plug on the return side (opposite to the wiper blade) of the end plate identified in the previous step.

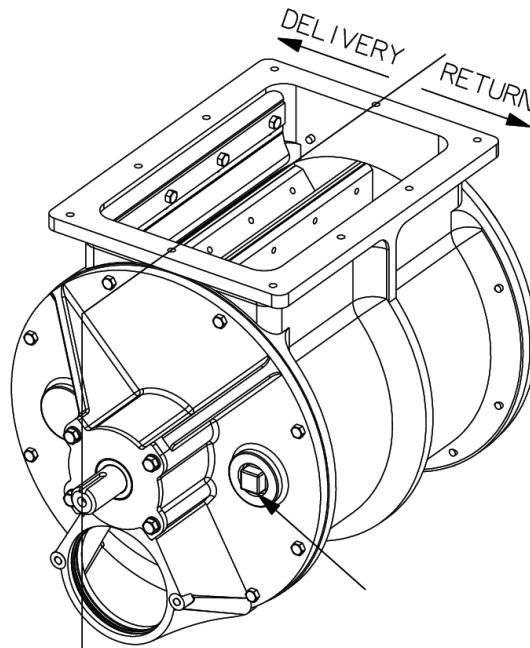

Figure 7-36: Vent plug removal

6. Ensure the internal surfaces of all tube **[Item A]** ends are smooth-beveled to prevent product build-up and flow restriction.

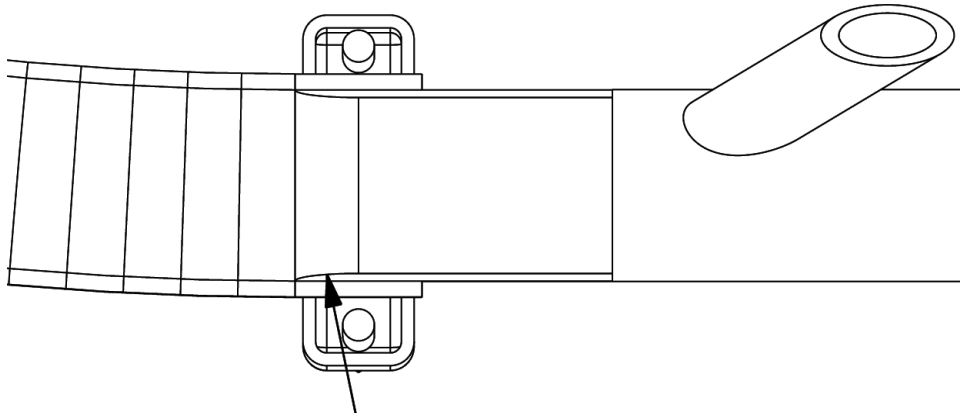

Figure 7-37: Smooth-beveled tube

7. Install the vent pipe **[Item A]** into the vent hole.

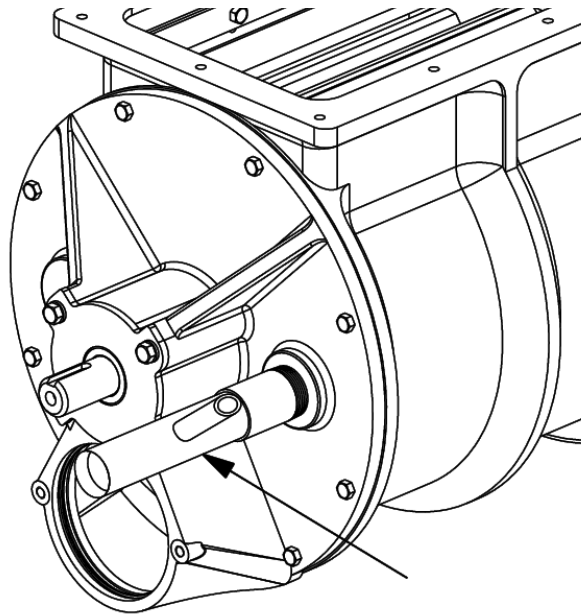

Figure 7-38: Vent pipe installation

8. Position and secure the vent discharge flex hose [Item B] to the vent pipe using a U-clamp [Item C].

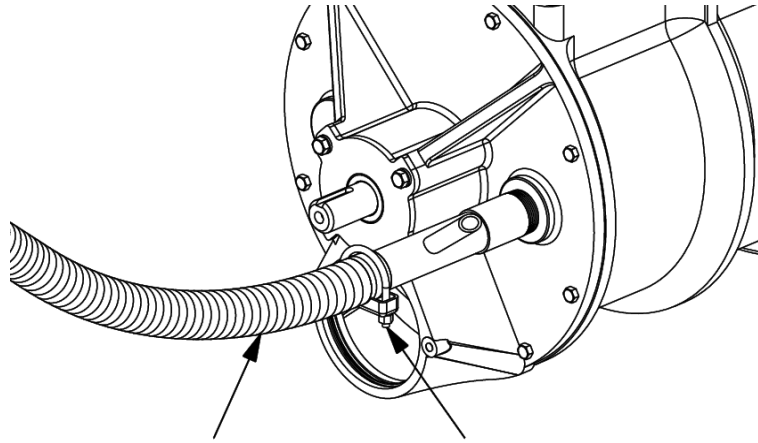

Figure 7-39: Flex hose installation

9. Identify the desired vent discharge point. The discharge point should be located in the product inlet structure above maximum capacity level to allow the small amount of material in the vented air to be discharged back into the inlet material collection area.
10. Install solid tubing [Item D] along the vent discharge path to minimize the number of bends.
11. Install the discharge flex hose [Item B] at any required bends, keeping minimum bend radius of 150 CLR to reduce any potential flow restriction. Secure the flex hose using U-clamps [Item C].
12. Install the pressurized air inlet assembly [Item E] equipped with the air take-off spigot and secure in place.

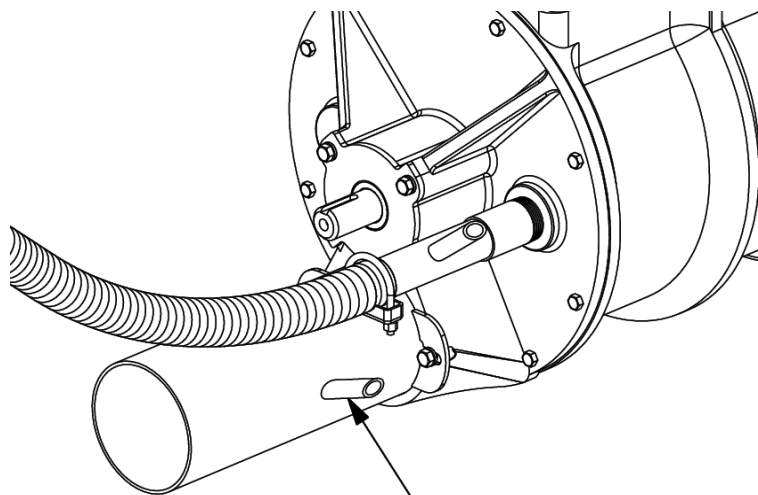

Figure 7-40: Example air inlet installation

13. Use the rubber connector hose [Item F] to join the spigot of the air inlet assembly [Item E] and vent pipe [Item A].

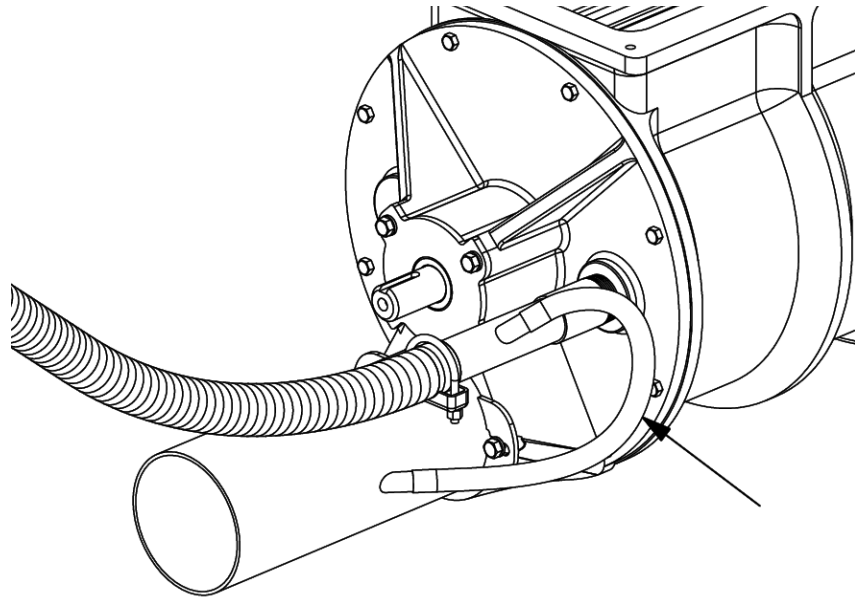

Figure 7-41: Connector hose installation

14. Secure the connector hose in place using hose clamps [Item G].

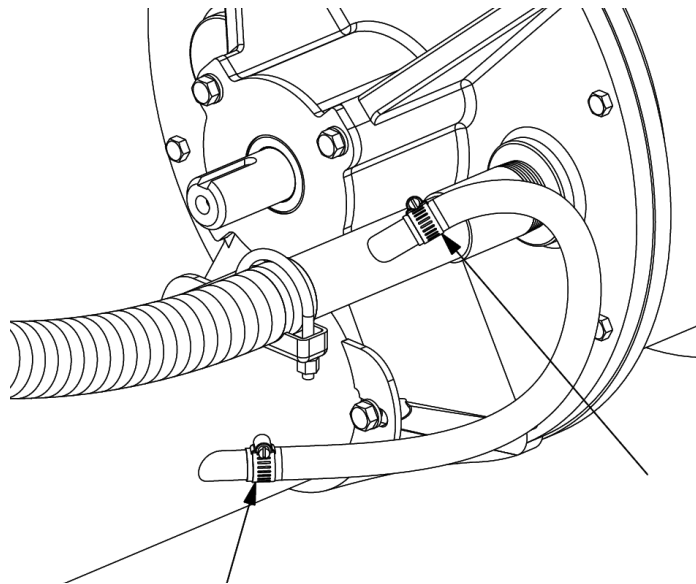

Figure 7-42: Gear clamp installation

15. Ensure all components and guards are properly installed and secured.

Pressure Monitoring Kit

For systems operating with a pressurized discharge, an air pressure gauge may be installed to better monitor the performance of the system or to identify potential issues.

To install a pressure monitoring kit, proceed as follows:

1. Clear the area of bystanders, especially small children.
2. Place all controls in neutral, stop and lock-out the power source, and wait for all moving parts to stop.
3. Ensure all required components, as detailed in **Table 7-6**, are ready and available.

Table 7-6: Pressure monitoring kit components

Item	Description	Walinga Part Number	Quantity
A	HALF COUPLING, 4FP	58-08815-6	1
B	FITTING, PUSH-IN, 4T-4MP	81-18109-6	1
C	PRESSURE GAUGE, 4MP, 0 TO 15 PSI	27-00718-6	1
D	COUPLING, 103-B, 1/4"	81-07112-6	1
E	FITTING, PUSH-IN, 4T-4MP 90	81-18110-6	1
F	1/4" AIR TUBE	73-03867-6	As Required

4. Examine the pressurized air inlet assembly, if it is equipped with a half coupling [**Item A**] and plug, remove the plug. If there is no half coupling installed, drill a hole into the inlet assembly pipe and fit and weld the half coupling [**Item A**] into place.

NOTE: The connection point must be installed on a straight section of tubing on the inlet (clean air) side of the airlock. **DO NOT** mount the connection point on an elbow, the underside of the tubing, or on the product discharge side of the airlock.

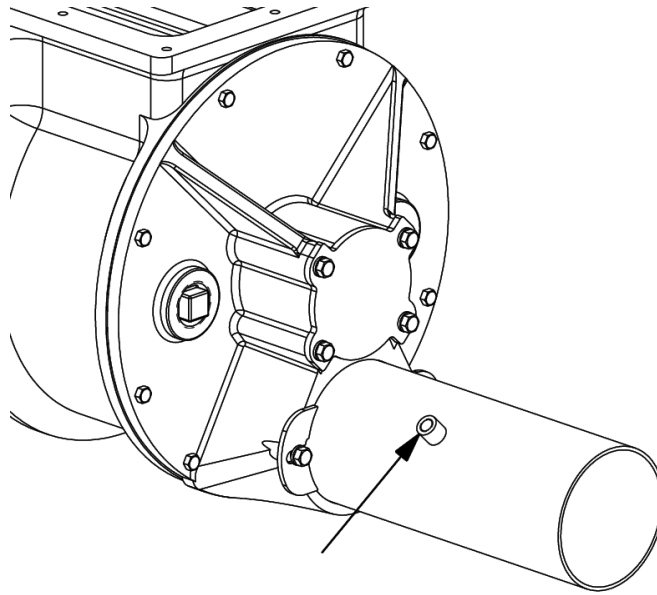

Figure 7-43: Half coupling positioning

5. Install the straight push-in fitting **[Item B]** into the half coupling **[Item A]**, applying thread sealant.

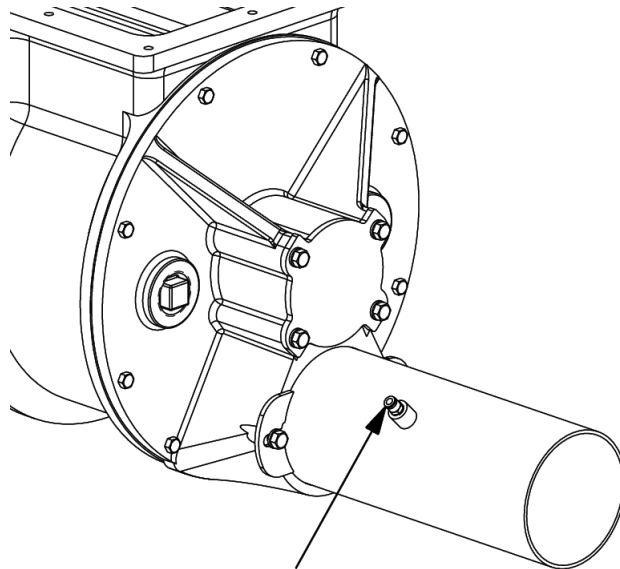

Figure 7-44: Half coupling fitting installation

6. Mount the pressure gauge **[Item C]** in a position that allows easy viewing by the operator, such as with the airlock motor controls.

7. Install the coupling [Item D] onto the stem of the pressure gauge, applying thread sealant.

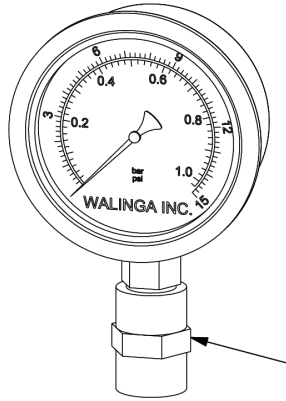

Figure 7-45: Pressure gauge coupling

8. Apply thread sealant and secure the 90° push-in fitting [Item E] into the coupling of the pressure gauge.

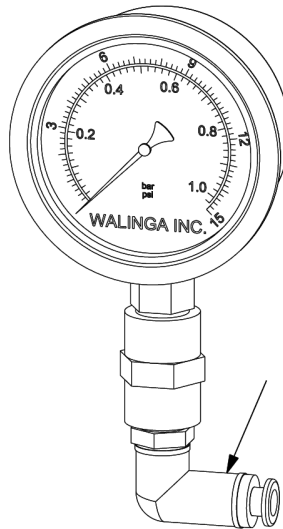

Figure 7-46: Pressure gauge fitting

9. Install the 1/4" air tube [Item F] onto both push-in fittings, avoiding any sharp bends in the tubing along the path from the airlock air inlet to the pressure gauge.
10. Ensure all components and guards are properly installed and secured.

Intake Hopper Installation

The airlock is a versatile machine, capable of operating with a variety of inlet and discharge configurations. In some instances, it may prove beneficial or necessary to alter the intake method of the airlock. Walinga provides a variety of hopper style intake assemblies specially designed to properly match each airlock model, refer to **Section 10: Accessories and Attachments**.

Warning: Unauthorized modification of a machine may result in serious injury or death and may impair the function, safety or life of the equipment, as well as void the warranty. It is the responsibility of the owner/operator to ensure that all moving parts and inlets are adequately guarded if an intake method substitution is made. The blades of the rotating airlock are dangerous and **MUST** be properly guarded at all times during operation. Do **NOT** operate the airlock without all guards in place.

To substitute the intake assembly of an airlock, proceed as follows:

1. Clear the area of bystanders, especially small children.
2. Place all controls in neutral, stop and lock-out the power source, and wait for all moving parts to stop.
3. Refer to the auxiliary equipment's operator's manual to remove the airlock inlet assembly.
4. Fit the intake hopper to the airlock inlet and secure in place.

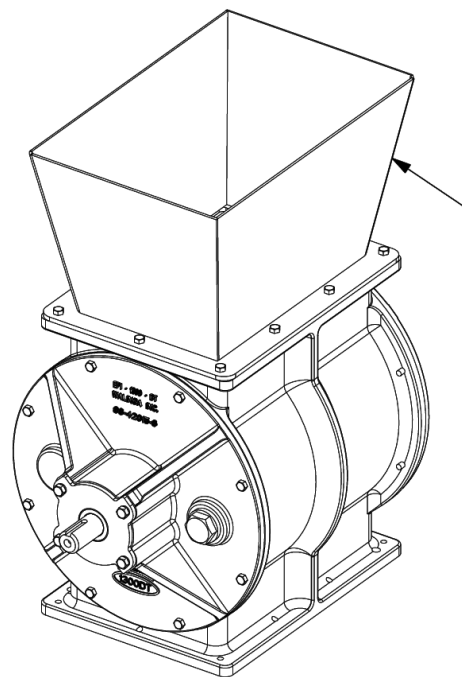

Figure 7-47: Intake hopper

5. Fit a mesh or slotted guard into the base of the intake hopper. The guard must be capable of supporting a minimum load of 270 lbs (123 kg) without permanent deformation with opening sizes in compliance with local or international guarding standards.

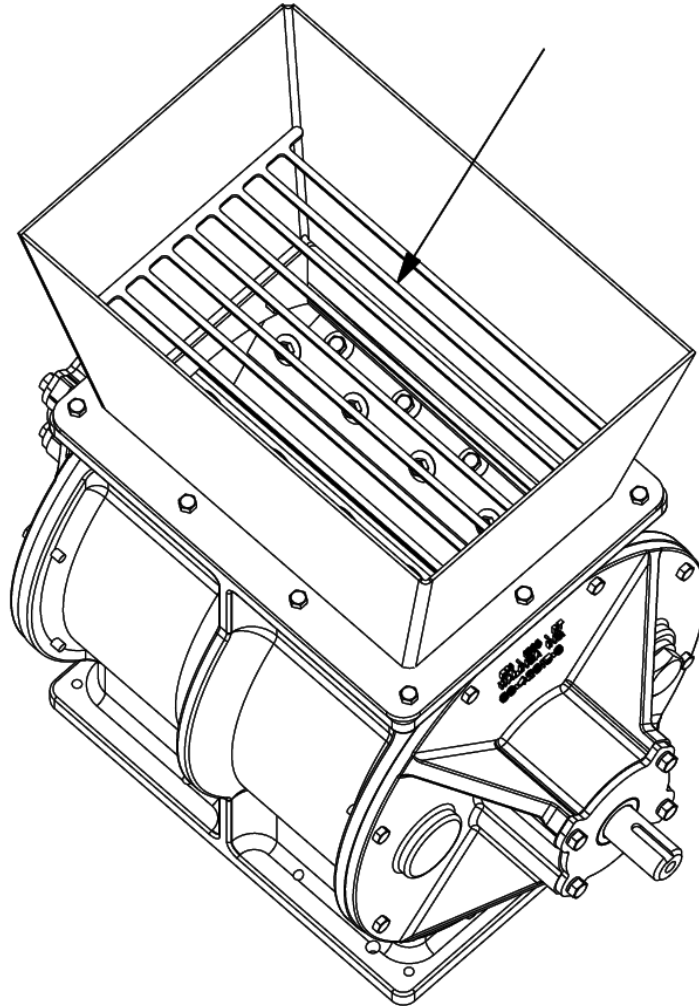

Figure 7-48: Inlet guard

6. During operation, ensure there is a continuous flow of product into the intake hopper. Gradually adjust the airlock speed to find the ideal balance between air and product for maximum capacity. Ensure the discharge air pressure does not exceed 10 psi (70 kPa). For systems with discharge lines greater than 100 ft (30 m), the discharge pressure must be reduced further to prevent blower overloading.

7. Some pressurized air will 'blow-back' through the airlock. This may cause bridging in the intake hopper. If the bridging disrupts the flow of product, either reduce the depth of product in the intake hopper, install an intake hopper equipped with a vent, or refer to the above section to install a *Pressure-Vent Kit*. Ensure any vent is installed on the return side of the airlock.

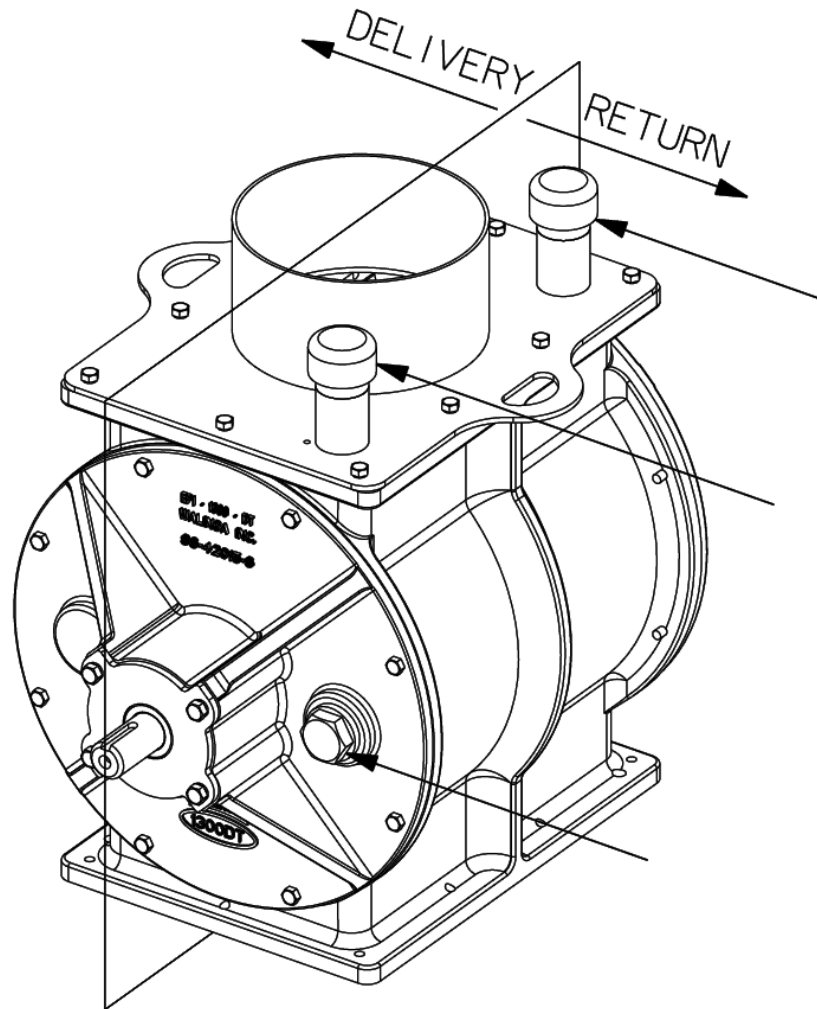

Figure 7-49: Correct vent positioning



Specifications

AIRLOCK MODELS

TECHNICAL DATA

Table 8-1: Blow-thru airlock specifications

	1314-4	1314-5	1618-6	1618-7	2018-7	2224-8
Capacity	0.8 cu ft/rev (23 L/rev)	0.8 cu ft/rev (23 L/rev)	1.6 cu ft/rev (45 L/rev)	1.6 cu ft/rev (45 L/rev)	2.69 cu ft/rev (76 L/rev)	4.44 cu ft/rev (126 L/rev)
Weight	270 lbs (123 kg)	270 lbs (123 kg)	480 lbs (218 kg)	480 lbs (218 kg)	970 lbs (440 kg)	1420 lbs (644 kg)
Inlet/Outlet Diameter [A]	4.000 in (10.2 cm)	5.00 in (12.7 cm)	6.00 in (15.2 cm)	7.00 in (17.8 cm)	7.00 in (17.8 cm)	8.00 in (20.3 cm)
Length [B]	25.500 in (64.8 cm)	25.500 in (64.8 cm)	29.375 in (74.6 cm)	29.375 in (74.375 cm)	34.813 in (88.4 cm)	39.375 in (100.0 cm)
Height [C]	16.875 in (42.9 cm)	16.875 in (42.9 cm)	19.250 in (48.9 cm)	19.875 in (50.5 cm)	26.375 in (67.0 cm)	28.000 in (71.1 cm)
Casing Diameter [D]	15.750 in (40.0 cm)	15.750 in (40.0 cm)	18.500 in (47.0 cm)	18.500 in (47.0 cm)	24.419 in (62.0 cm)	26.000 in (66.0 cm)
Shaft Diameter [E]	1.250 in (3.2 cm)	1.250 in (3.2 cm)	1.375 in (3.5 cm)	1.375 in (3.5 cm)	2.000 in (5.1 cm)	2.000 in (5.1 cm)
Keyway [F]	0.313 in (0.80 cm)	0.313 in (0.80 cm)	0.313 in (0.80 cm)	0.313 in (0.8 cm)	0.500 in (1.3 cm)	0.500 in (1.3 cm)

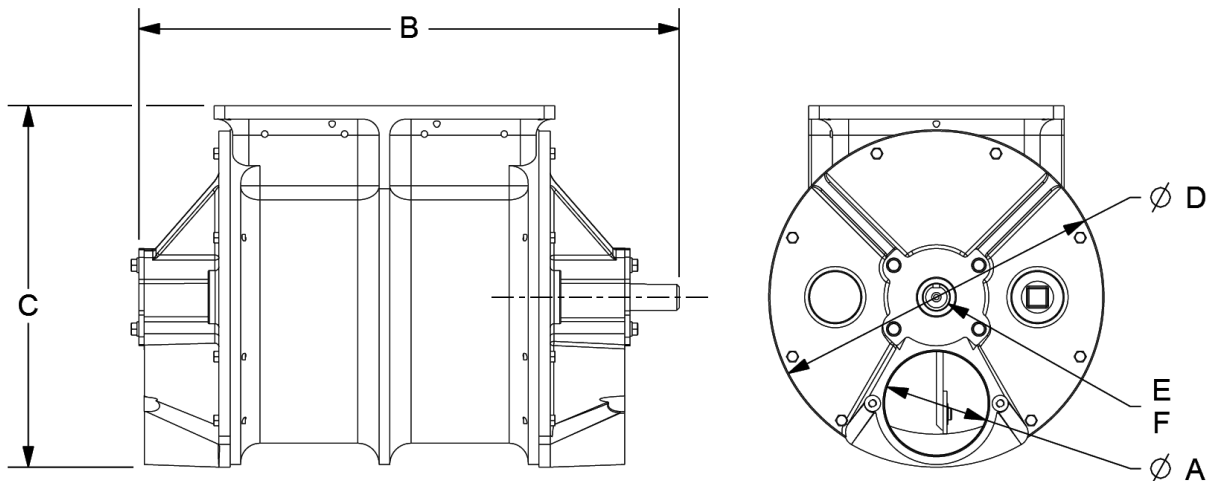

Figure 8-1: Blow-thru airlock reference dimensions

Table 8-2: Drop-thru airlock specifications

	1008	1210	1314	1618	2224
Capacity	0.28 cu ft/rev (8 L/rev)	0.55 cu ft/rev (16 L/rev)	0.8 cu ft/rev (23 L/rev)	1.6 cu ft/ rev (45 L/rev)	4.44 cu ft/rev (126 L/rev)
Weight	200 lbs (91 kg)	223 lbs (101 kg)	340 lbs (154 kg)	521 lbs (236 kg)	1481 lbs (672 kg)
Length [A]	21.375 in (54.3 cm)	19.000 in (48.3 cm)	25.313 in (64.3 cm)	27.450 in (69.7 cm)	37.140 in (94.3 cm)
Height [B]	15.000 in (38.1 cm)	16.125 in (41.0 cm)	17.750 in (45.1 cm)	21.000 in (53.3 cm)	28.000 in (71.1 cm)
Casing Diameter [C]	12.375 in (31.4 cm)	14.250 in (36.2 cm)	15.750 in (40.0 cm)	18.500 in (47.0 cm)	26.000 in (66.0 cm)
Shaft Diameter [D]	1.500 in (3.8 cm)	1.750 in (4.4 cm)	1.75 in (4.4 cm)	1.750 in (4.4 cm)	2.500 in (6.35 cm)
Keyway [E]	0.375 in (0.9 cm)	0.375 in (0.9 cm)	0.375 in (0.9 cm)	0.375 in (0.9 cm)	0.625 in (1.6 cm)

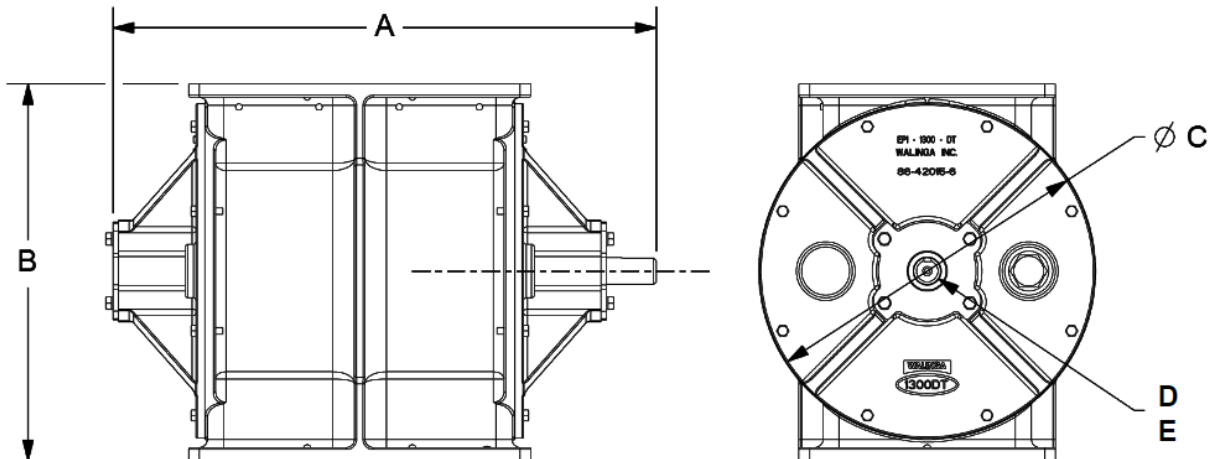

Figure 8-2: Drop-thru airlock reference dimensions

BOLT TORQUES

The critical required torque values for the airlock fasteners are identified in **Table 8-3**. For any fasteners not specified in **Table 8-3**, refer to **Table 8-4** and **Table 8-5** for imperial and metric bolt torque requirements respectively. Check the tightness of bolts periodically. Replace any damaged or lost hardware with the same strength fastener. Torque values indicated in the following tables are valid for non-greased or non-oiled threads and heads. Unless otherwise specified, do not grease or oil bolts or cap screws. When using locking elements, increase the listed torque values by 5%. Reference **Figure 8-11** and **Figure 8-12** for proper grade identification.

Table 8-3: Fastener torque specifications

	1008	1210	1314	1618	2018	2224
Blade Tip Bolts <i>Figure 8-3</i>	—	28 ft-lb (38.0 Nm)	28 ft-lb (38.0 Nm)	24 ft-lb (32.5 Nm)	28 ft-lb (38.0 Nm)	24 ft-lb (32.5 Nm)
Wiper Blade Bolts <i>Figure 8-4</i>	12 ft-lb (16.3 Nm)	—	24 ft-lb (32.5 Nm)	24 ft-lb (32.5 Nm)	24 ft-lb (32.5 Nm)	—
Rotor Shaft Lock Collar <i>Figure 8-5</i>	16 ft-lb (21.7 Nm)	28 ft-lb (38.0 Nm)	—	—	—	—
Rotor Shaft Lock Nut <i>Figure 8-6</i>	—	Minimum 40 ft-lb (54.2 Nm)	Minimum 40 ft-lb (54.2 Nm)	Minimum 60 ft-lb (81.3 Nm)	Minimum 85 ft-lb (115.2 Nm)	Minimum 85 ft-lb (115.2 Nm)
Lock Nut Set Screw <i>Figure 8-7</i>	—	29 ft-lb (39.3 Nm)	29 ft-lb (39.3 Nm)	29 ft-lb (39.3 Nm)	29 ft-lb (39.3 Nm)	29 ft-lb (39.3 Nm)
End Plate Bolts <i>Figure 8-8</i>	24 ft-lb (32.5 Nm)	24 ft-lb (32.5 Nm)	24 ft-lb (32.5 Nm)	24 ft-lb (32.5 Nm)	24 ft-lb (32.5 Nm)	24 ft-lb (32.5 Nm)
Seal Plate Bolts <i>Figure 8-9</i>	24 ft-lb (32.5 Nm)	24 ft-lb (32.5 Nm)	24 ft-lb (32.5 Nm)	24 ft-lb (32.5 Nm)	24 ft-lb (32.5 Nm)	24 ft-lb (32.5 Nm)
Air Vent Plug <i>Figure 8-10</i>	—	24 ft-lb (32.5 Nm)	24 ft-lb (32.5 Nm)	24 ft-lb (32.5 Nm)	—	24 ft-lbs (32.5 Nm)

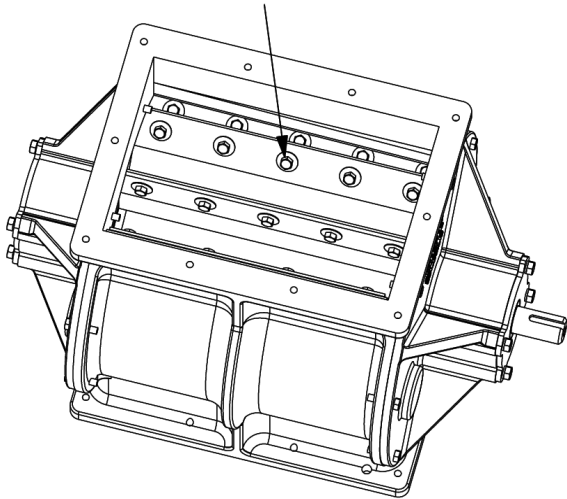

Figure 8-3: Blade tip bolts

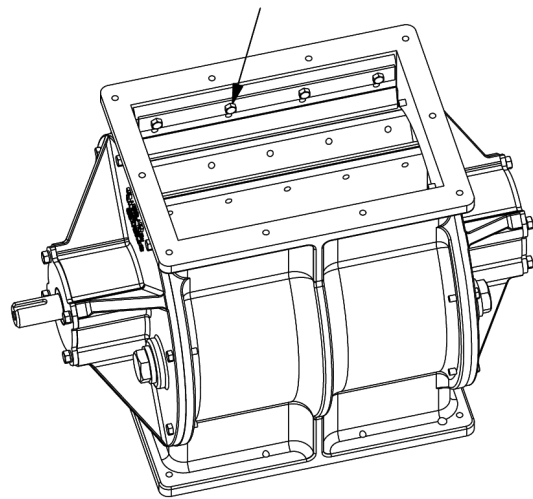

Figure 8-4: Wiper blade bolts

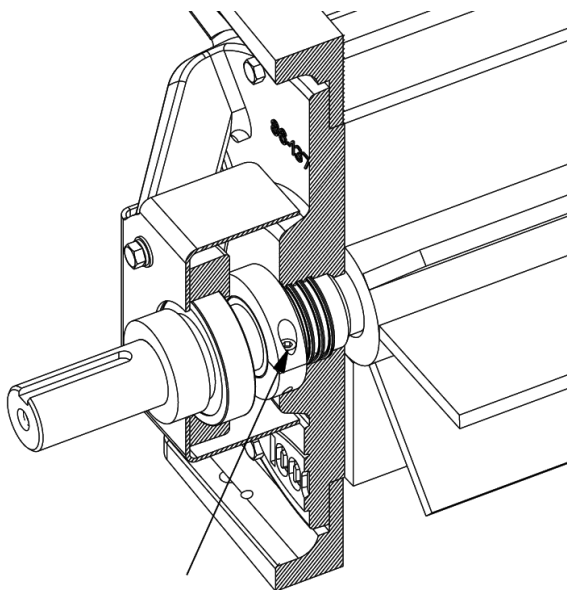

Figure 8-5: Rotor shaft lock collar

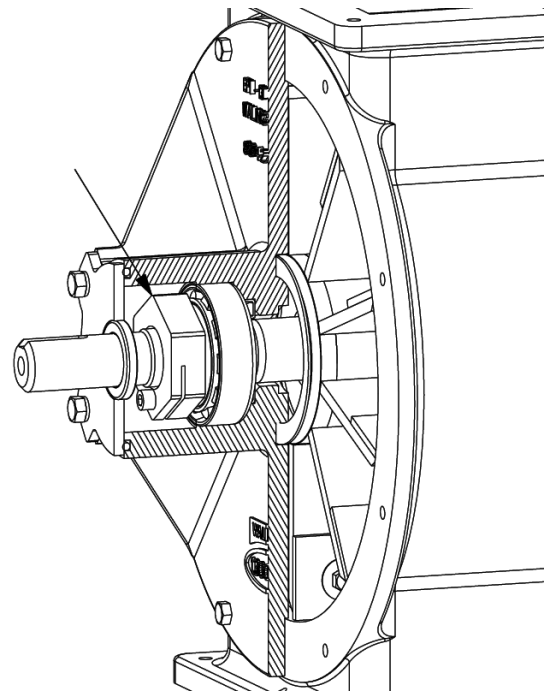

Figure 8-6: Rotor shaft lock nut

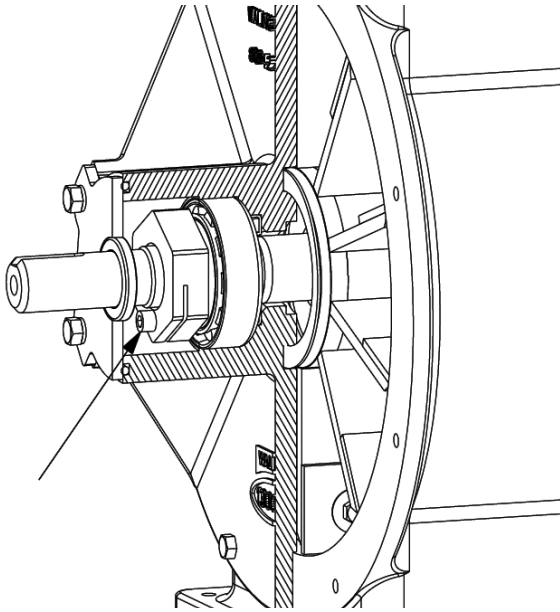

Figure 8-7: Lock nut set screw

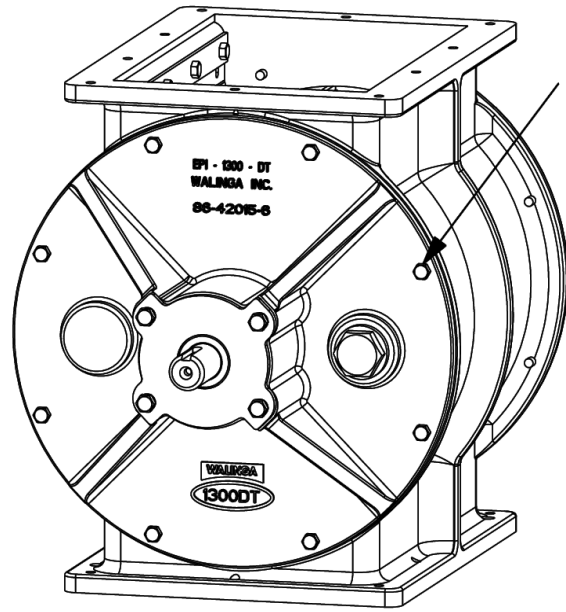

Figure 8-8: End plate bolts

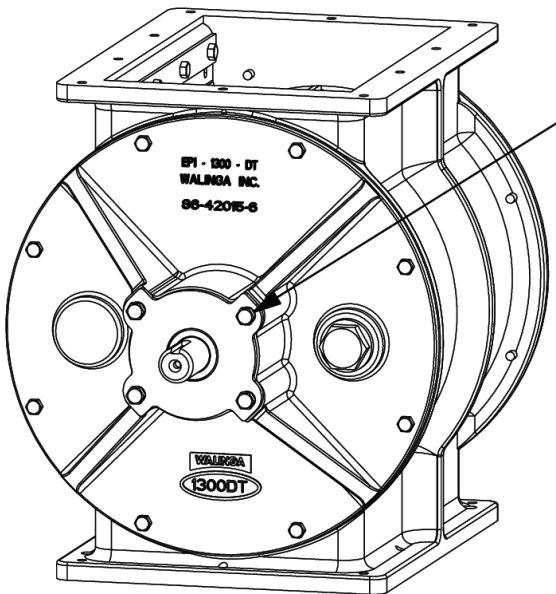

Figure 8-9: Seal plate bolts

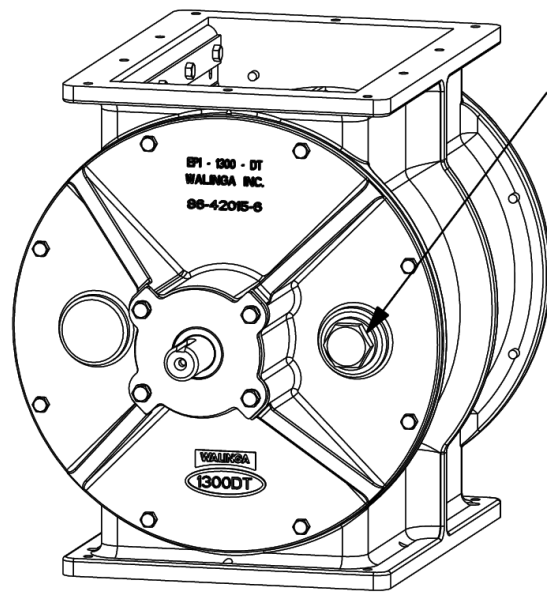

Figure 8-10: Air vent plug

Table 8-4: Imperial torque specifications

Bolt Diameter "A" [in]	Bolt Torque					
	SAE 2		SAE 5		SAE 8	
	[Nm]	[lb-ft]	[Nm]	[lb-ft]	[Nm]	[lb-ft]
1/4	8	6	12	9	17	12
5/16	13	10	25	19	36	27
3/8	27	20	45	33	63	45
7/16	41	30	72	53	100	75
1/2	61	45	110	80	155	115
9/16	95	60	155	115	220	165
5/8	128	95	215	160	305	220
3/4	225	165	390	290	540	400
7/8	230	170	570	420	880	650
1	345	225	850	630	1320	970

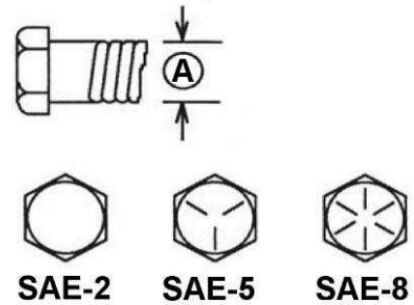

Figure 8-11: Imperial bolts

Table 8-5: Metric torque specifications

Bolt Diameter "A"	Bolt Torque			
	8.8		10.9	
	[Nm]	[lb-ft]	[Nm]	[lb-ft]
M3	.5	.4	1.8	1.3
M4	3	2.2	4.5	3.3
M5	6	4	9	7
M6	10	7	15	11
M8	25	18	35	26
M10	50	37	70	52
M12	90	66	125	92
M14	140	103	200	148
M16	225	166	310	229
M20	435	321	610	450
M24	750	553	1050	774
M30	1495	1103	2100	1550
M36	2600	1917	3675	2710

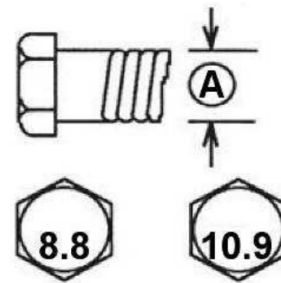

Figure 8-12: Metric bolts

STANDARDS AND REGULATIONS

Walinga follows the general safety standards specified by the American Society of Agricultural Engineers (ASAE) and the Occupational Safety and Health Administration (OSHA) with consideration of standards outlined by the National Fire Prevention Agency (NFPA), International Organization for Standardization (ISO), Occupational Health and Safety Standards (OH&S), and American National Standards Institute (ANSI). Be aware that there may be additional local or federal laws and regulations that require compliance based on operational location that are the responsibility of the owner and/or operator. For your convenience, the standards referenced in this manual and pertinent to airlocks are listed below.

NFPA 652	Standard on the Fundamentals of Combustible Dust
ISO 4254-1	Agricultural Machinery - Safety - Part 1: General Requirements
NFPA 70	National Electric Code



PAGE INTENTIONALLY LEFT BLANK



Warranty

AFTERMARKET PARTS AND SERVICE

Walinga Inc. is committed to providing a quality product that will meet or exceed expectations for many years to come. The warranty terms and warranty claim process have been designed to ensure that each warranty claim will be resolved in an orderly, fair and timely manner.

THE WARRANTY

Walinga Inc. ("Walinga") warrants that all new pneumatic products sold by Walinga will be free from defects in material and workmanship (the "Walinga Warranty").

WARRANTY PERIOD

The warranty period for Walinga parts shall expire six (6) months after the date of sale to the original customer; with the exception of parts purchased from a Walinga authorized dealer. In these situations, the warranty period shall expire six (6) months after the date of sale recorded on the dealer's Sales Order to their customer.

Parts which are purchased from Walinga and installed at a Walinga service facility, a Walinga authorized dealer, or a Walinga authorized service facility will qualify for a six (6) month warranty extension; bringing the total warranty period for these items to one (1) year from the date of their installation.

The warranty period for Walinga blowers and airlocks shall expire twelve (12) months after the date of sale to the original customer.

LIMITATIONS AND EXCLUSIONS OF THE WALINGA WARRANTY

- The Walinga Warranty applies to material and workmanship only.
- With respect to any component parts that are supplied or manufactured by others, the warranty coverage on such component parts will be strictly limited to the warranties of the manufacturers of such component parts.
- The Walinga Warranty shall only be for the benefit of the original purchaser of the aftermarket parts and service.
- A Walinga Warranty may be transferable by the original purchaser to a third party for the balance of the warranty period then remaining, provided that Walinga consents in writing to such a transfer of warranty.
- The Walinga Warranty is conditional upon proper storage, installation, use, maintenance, operation, and compliance with any applicable recommendations of Walinga.

WARRANTY CLAIM PROCEDURE

Should any difficulties with a unit within its warranty period be encountered, please contact a local Walinga dealer or sales representative, the local Walinga Service Department or Walinga's Warranty Department to submit a warranty claim application.

To speak with a Walinga Warranty Coordinator, contact:

		USA	1-800-466-1197 (ext 8) warranty.usa@walinga.com
Canada and International	1-888-WALINGA (ext 273) +1-519-824-8520 (ext 273) warranty.canada@walinga.com	Australia	07-4634-7344 mail@customvac.com.au

REQUIRED WARRANTY CLAIM INFORMATION

The following information must be provided to Walinga for proper consideration and processing of a warranty application:

- Customer name and contact information, including email if available
- The original Sales Order number and Vehicle Identification Number (VIN), if applicable
- Date of claimed failure
- Details, description and photos (upon request) of the claimed failure and the corrective repairs attempted

WARRANTY CONDITIONS

- Parts Warranty term begins on the date of purchase by the original purchaser; with the exception of items purchased from a Walinga authorized dealer, in which case the warranty period will begin on the purchase date recorded on the dealer's Sales Order to their customer.
- The buyer is responsible for promptly notifying Walinga of any defects to the parts to the parts or workmanship, and making the equipment available to Walinga or its authorized facility for evaluation or repair.
- Prior to making any repairs or parts replacements, a warranty application and any estimated associated costs must be approved with the issuance of a claim number by an authorized Walinga representative. Undertaking any work prior or part replacement prior to receiving warranty authorization may result in a partial or complete loss of warranty coverage.
- Walinga is not responsible for the cost of labor associated with part removal or installation performed by the customer or service providers other than Authorized Dealers and Service Centers or the costs of parts and labor associated with the repair or replacement of parts resulting from the use of non-Walinga approved parts and/or parts that do not meet Walinga specifications.
- At Walinga's request, parts in question must be returned to the nearest Walinga service facility for evaluation. In such situations, a Returned Goods Authorization (RGA) number will be provided to the customer. The returning shipment must be clearly labeled with the assigned RGA number and include a copy of the RGA form. Unless otherwise arranged, these parts are to be returned to Walinga within thirty (30) days to ensure timely processing of the warranty claim. Failure to return such parts may result in partial or complete loss of warranty coverage.
- Replacement parts provided under warranty are covered for the remainder of the original purchased parts or service warranty period.
- Walinga reserves the right to use new, remanufactured or refurbished components when performing warranty repairs and replacements.
- Walinga is entitled to a reasonable amount of time and a reasonable number of attempts to assess the claim, diagnose the problem, and perform any necessary repairs.
- The warranty offered on used or refurbished parts is limited to that specified on the Sales Order. Where a warranty period has not been stipulated on the purchase contract, such equipment is considered to be sold "as is, where is".

WARRANTY CLAIM REJECTION

Without limitation, Walinga reserves the right to reject a warranty claim for any one or more of the following reasons:

- The warranty claim information provided is insufficient.
- The product evaluation does not substantiate the claim.
- The unit has been operated above and beyond its capacity or not maintained or serviced properly, resulting in damages incurred to major components.
- It is apparent that the operator's manuals have not been followed.

NOT COVERED UNDER WARRANTY

Without limitation, the Walinga Warranty does not cover:

- Damage or deterioration due to lack of reasonable care or maintenance.
- Damage caused or affected by unapproved modifications to the equipment.
- Damage caused by negligence or misuse of the equipment.
- Damage caused by improper repair of equipment or incorrect installation of components.
- Damage caused by using the equipment for purposes for which it was not designed or intended.

Walinga's liability under this warranty, whether in contract or tort, is limited to the repair, replacement or adjustment of defective materials and workmanship. In no event will Walinga be responsible for any direct, indirect, loss of time, incidental or consequential expenses including, but not limited to equipment rental expenses, towing, downtime, inconvenience, or any losses resulting from the inability to use the equipment. Further, Walinga shall not be liable for any damages or inconvenience caused by any delay in the supply of any equipment or component parts thereof.

The selling dealer/salesperson makes no warranty of its own and has no authority to make any representation or promise on behalf of Walinga, or to modify the terms or limitations of the Walinga Warranty in any way.

Punitive, exemplary or multiple damages may not be recovered unless applicable law prohibits their disclaimer.

Warranty related claims may not be brought forward as a class representative, a private attorney general, a member of a class of claimants or in any other representative capacity.

The Walinga Warranty and all questions regarding its enforceability and interpretation are governed by the law of the country, state or province in which the Walinga equipment was purchased. The laws of some jurisdictions limit or do not allow the disclaimer of consequential damages. If the laws of such a jurisdiction apply to any claim against Walinga, the limitations and disclaimers contained here shall be to the greatest extent permitted by law.



Accessories and Attachments

AIRLOCK MODELS

A wide variety of accessories are available for your airlock model to improve your operational experience. Below are some of the available accessories and a general description of their function. Please contact your Walinga dealer or representative for accessories compatible with your specific airlock, availability and ordering, or if you have any questions.

COUPLERS

To accommodate the different coupling styles of various industries and applications, a range of couplers are available in different styles and sizes.

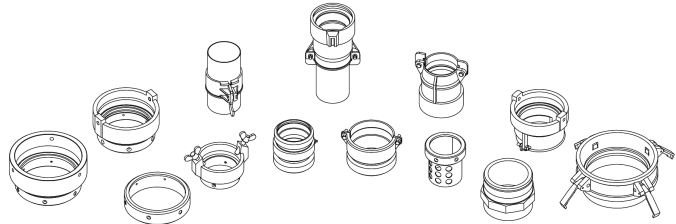

ADAPTERS AND REDUCERS

To accommodate the different coupling styles that are used in varying industries as well as the couplings of different hoses, lines and nozzles, various adapters and reducers are available for easy connection in varying styles and sizes.

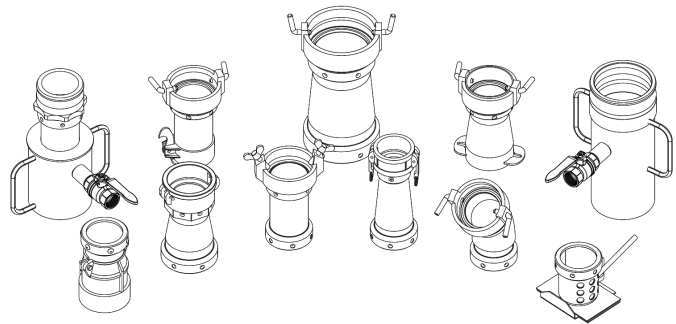

OUTLET ASSEMBLIES

To accommodate the wide range of conveyed products, and system configurations, a range of outlet styles are available. Pan outlets are optimal for heavy products, U-trough outlets are ideal for airlocks positioned in series, couplers provide easy connection to interchangeable discharge lines, and bins provide collection of fine products where the discharge is not pressurized.

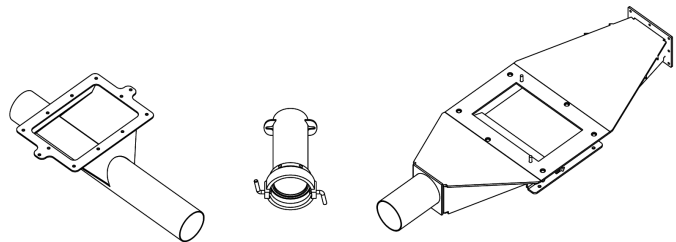

INLET HOPPERS

To accommodate operation of an airlock with a more open and accessible inlet, an inlet hopper may be installed. Guards and inlet assemblies equipped with pressure vents to prevent 'blow-back' bridging are also available.

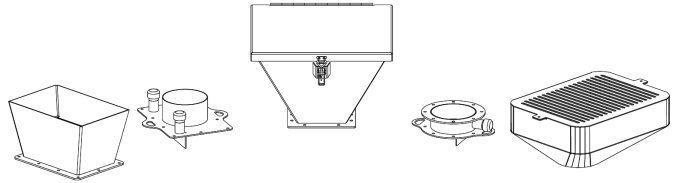

MAGNETIC INLET COVERS

In operations where conveyed products may be contaminated with metallic debris, magnetic inlet covers are available to remove the contaminants from the product.

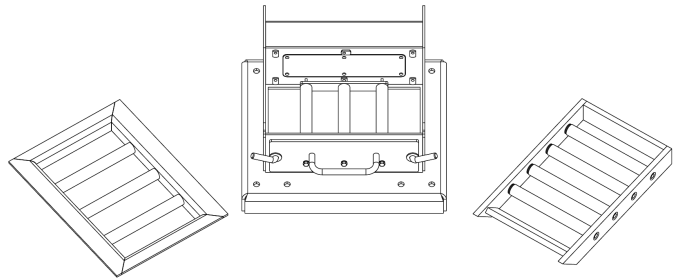

PRESSURE-VENT KIT

To accommodate the varying conveyed product characteristics, especially for light materials, a pressure-vent kit is available to reduce bridging and 'blow-back' issues.

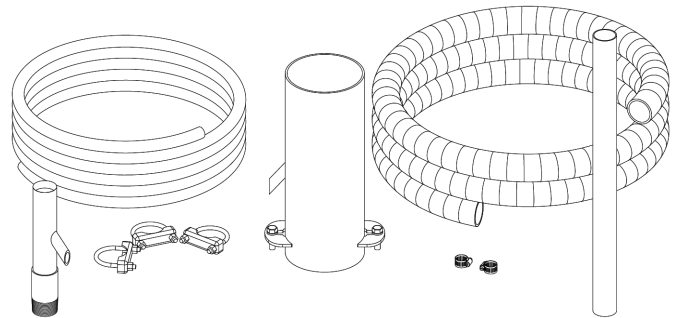

DISCHARGE PRESSURE KIT

To allow better monitoring of the performance and to provide potential issue diagnostic information, a discharge pressure monitoring kit is available.

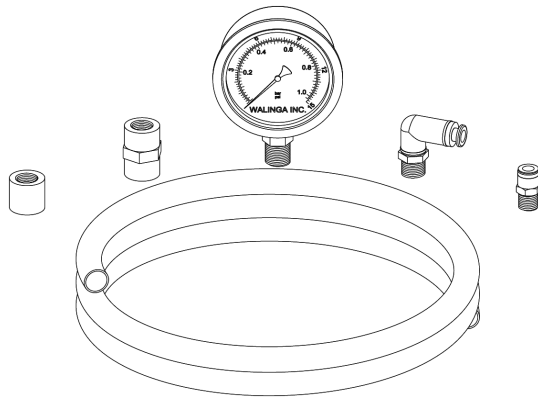



PAGE INTENTIONALLY LEFT BLANK



Parts List

AIRLOCK 1314 MODEL

MODEL REFERENCES

Refer to **Section 3: Machine Configuration** for detailed information regarding the naming and short forms of various key features of the airlock.

Refer to **Table 11-1** for the top level assembly numbers of each airlock and their respective key features. The reference codes for each model assigned in **Table 11-1** will be used as the top-level model identification for the remainder of this section.

Table 11-1: Top-level model assemblies

Reference Code	Assembly Number	Features																		
		Body							Rotor					Tips/Blade						
		Drop-Thru	Style			Hard Coating	Stainless Steel	Abrasive	Outboard Bearing	Halar	Mounting		Closed	Stainless Steel	Clockwise	Adjustable			Solid	
			Size	*A	*B						Fixed	Floating				Square	Bevel	Flex	Square	Bevel
A	30-95273-5	X								X					X					
B	30-110001-5	X								X						X				
C	30-109915-5	X			X					X					X					
D	30-74829-5	X			X					X						X				
E	30-110150-5	X			X					X							X			
F	30-153536-5	X			X		X			X					X					
G	30-113778-5	X			X		X			X						X				
H	30-110003-5	X			X		X			X			X						X	

CONTINUED ON NEXT PAGE

CONTINUED FROM PREVIOUS PAGE

Reference Code	Assembly Number	Features																		
		Body									Rotor					Tips/Blade				
		Style				Hard Coating	Stainless Steel	Abrasive	Outboard Bearing	Halar	Mounting		Closed	Stainless Steel	Clockwise	Adjustable			Solid	
		Drop-Thru	Blow-Thru								Fixed	Floating				Square	Bevel	Flex	Square	Bevel
Size	.*A		.*B																	
I	30-04108-5		4"	X							X					X				
J	30-90294-5		4"	X							X					X				
K	30-04464-5		4"	X							X						X			
L	30-37902-5		4"	X		X					X					X				
M	30-45682-5		4"	X		X					X						X			
N	30-97430-5		4"	X		X		X			X						X			
O	30-40673-5		5"	X							X					X				
P	30-42018-5		5"	X		X					X					X				
Q	30-98688-5		5"	X		X		X			X						X			
R	30-09000-5		5"		X						X					X				
S	30-09001-5		5"		X						X						X			
T	30-36330-5		5"		X	X					X					X				
U	30-77833-5		5"		X	X					X						X			
V	30-97798-5		5"		X	X		X			X						X			

BODY COMPONENTS

CASING

(Drop-Thru)

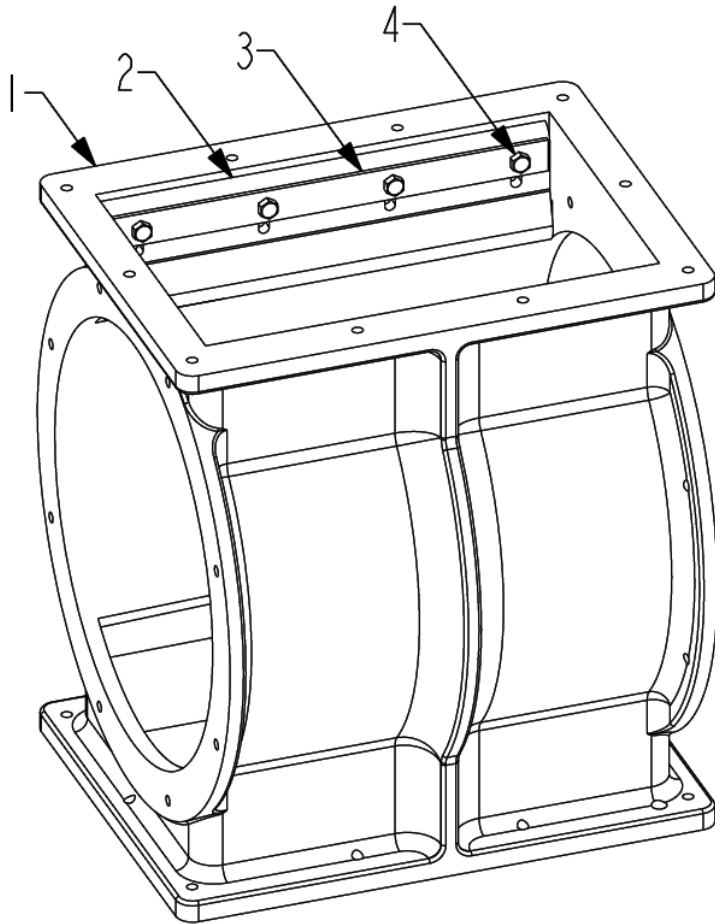

Model		Description	Part Number
A, B	1	CASING, 1314 DT	30-42012-4
C, D, E	1	CASING, 1314 DT, HC	30-73558-4
F, G	1	CASING, 1314 DT, HC, ABR	30-114151-4
H	1	CASING, 1314 DT, FULL HC, ABR	30-110132-4
A, B, C, D, E, F	2	TIP WIPER, 1314	30-20471-4
G, H	2	TIP WIPER, 1314, SS	30-40020-4
A, B, C, D, E, F	3	TIP WIPER WASHER PLATE, 1314	30-36866-4
G, H	3	BELLEVILLE WASHER, 1"	94-13003-6
A, B, C, D, E, F, G, H	4	BOLT, 5/16/18-1, GR 8, PLTD	94-05284-6

(Blow-Thru)

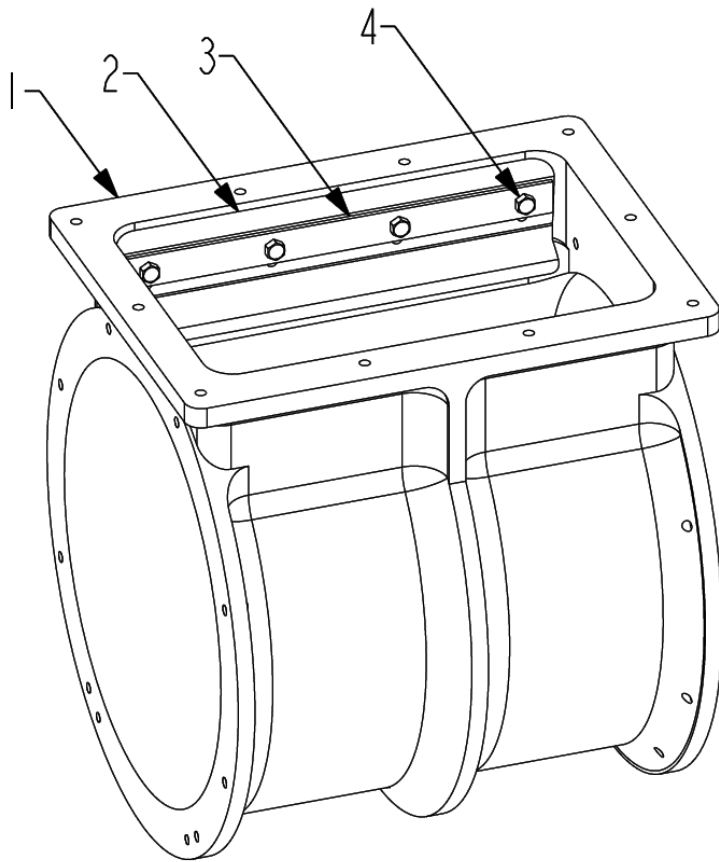

Model		Description	Part Number
I, J, K, O	1	CASING, 1314-A	30-09024-4
L, M, P	1	CASING, 1314-A, HC	30-37811-4
N, Q	1	CASING, 1314-A, HC, ABR	30-114153-4
R, S	1	CASING, 1314-B	30-07979-4
T, U	1	CASING, 1314-B, HC	30-37809-4
V	1	CASING, 1314-B, HC, ABR	30-114152-4
I, L, O, P, R, T, U	2	TIP WIPER, 1314	30-20471-4
	3	TIP WIPER WASHER PLATE, 1314	30-36866-4
	4	BOLT, 5/16/18-1, GR 8, PLTD	94-05284-6
J	2	TIP WIPER, 1314	30-20471-4
	3	TIP WIPER WASHER PLATE, SS	30-99142-4
	4	BOLT, 5/16/18-1, GR 8, PLTD	94-05284-6
K, M, N, Q, S, V	2	TIP WIPER, 1314, SS	30-40020-4
	3	BELLEVILLE WASHER, 1"	94-13003-6
	4	BOLT, 5/16-18-5/8, GR 8, PLTD	94-61715-6

END PLATE

(Drop-Thru)

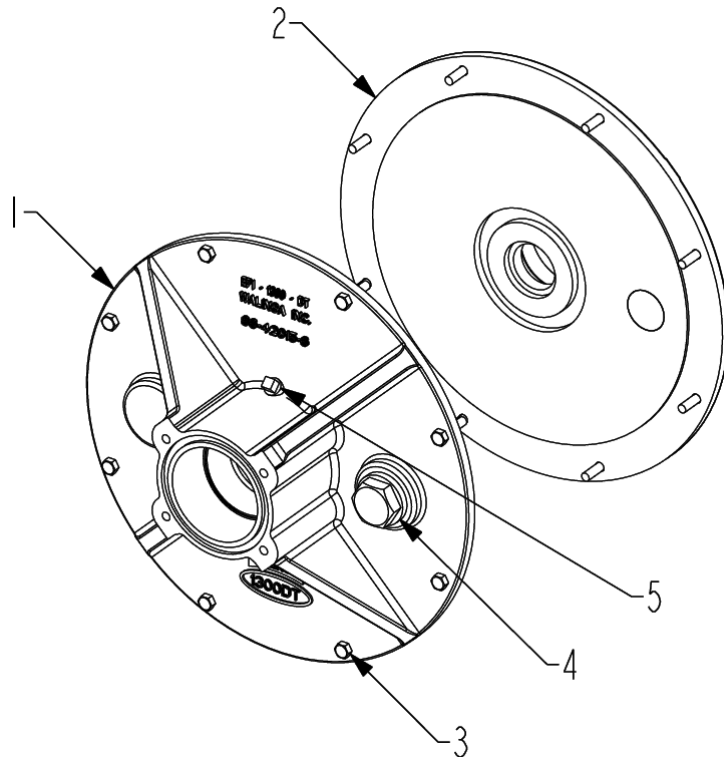

Model		Description	Part Number
A, B	1	END PLATE, 1314 DT, DRIVE	30-95274-4
C, D, E	1	END PLATE, 1314 DT, DRIVE, HC	30-109998-4
F, G, H	1	END PLATE, 1314 DT, HC, ABR	30-110129-4
A, B	2	END PLATE, 1314 DT, IDLE	30-95275-4
C, D, E	2	END PLATE, 1314 DT, IDLE, HC	30-109997-4
F, G, H	2	END PLATE, 1314 DT, HC, ABR	30-110129-4
A, B, C, D, E, F, G, H	3	BOLT, 5/16-18-1 1/4, GR 8, PLTD	94-05286-6
A, B, C, D, E	4	PLUG, SAE 20, w/ O-RING	30-49203-4
F, G, H	5	PLUG, 6MP	58-01165-6

(Blow-Thru)

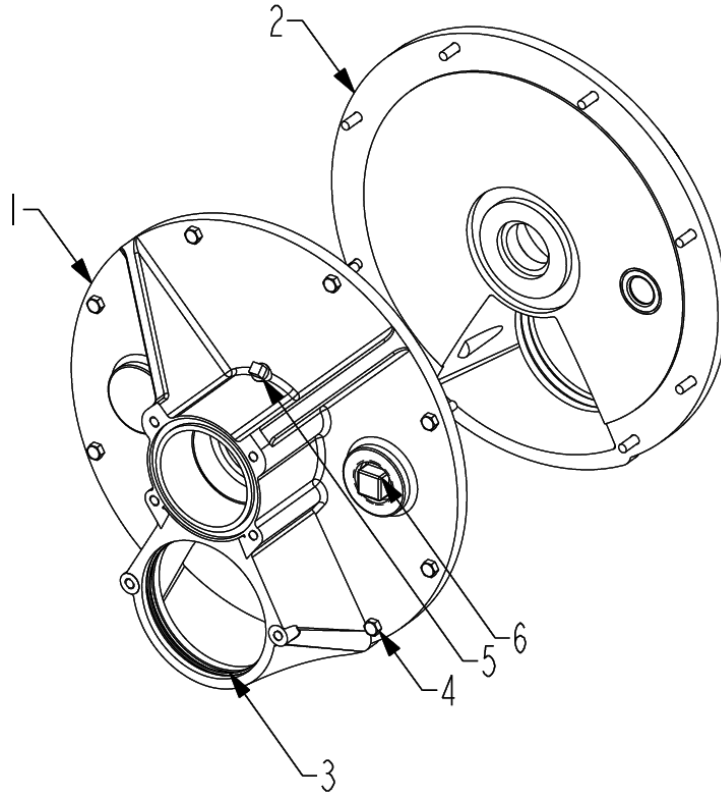

Model		Description	Part Number
I, J, K	1	END PLATE, 1314-4, DRIVE	30-57053-4
L, M	1	END PLATE, 1314-4, DRIVE, HC	30-98279-4
N	1	END PLATE, 1314-4, DRIVE, HC, ABR	30-97434-5
O, R, S	1	END PLATE, 1314-5, DRIVE	30-57624-4
P, T, U	1	END PLATE, 1314-5, DRIVE, HC	30-66092-4
Q, V	1	END PLATE, 1314-5, DRIVE, HC, ABR	30-97800-5
I, J, K	2	END PLATE, 1314-4, IDLE	30-08619-4
L, M	2	END PLATE, 1314-4, IDLE, HC	30-98280-4
N	2	END PLATE, 1314-4, IDLE, HC, ABR	30-97435-5
O, R, S	2	END PLATE, 1314-5, IDLE	30-09021-4
P, T, U	2	END PLATE, 1314-5, IDLE, HC	30-37808-4
Q, V	2	END PLATE, 1314-5, IDLE, HC, ABR	30-97799-5
I, J, K, L, M, N	3	SEAL, U-CUP, 4"	96-03146-6
O, P, Q, R, S, T, U, V	3	SEAL, U-CUP, 5"	96-05978-6
I, J, K, L, M, N, O, P, Q, R, S, T, U, V	4	BOLT, 5/16-18-1 1/4, GR 8, PLTD	94-05286-6
N, Q, V	5	PLUG, 6MP	58-01165-6
I, J, K, L, M, N, O, P, R, S, T, U	6	PLUG, 1 1/4", SQ HEAD	58-01173-6
Q, V	6	PLUG, SAE 20, w/ O-RING	30-49203-4

ROTOR COMPONENTS

ROTOR

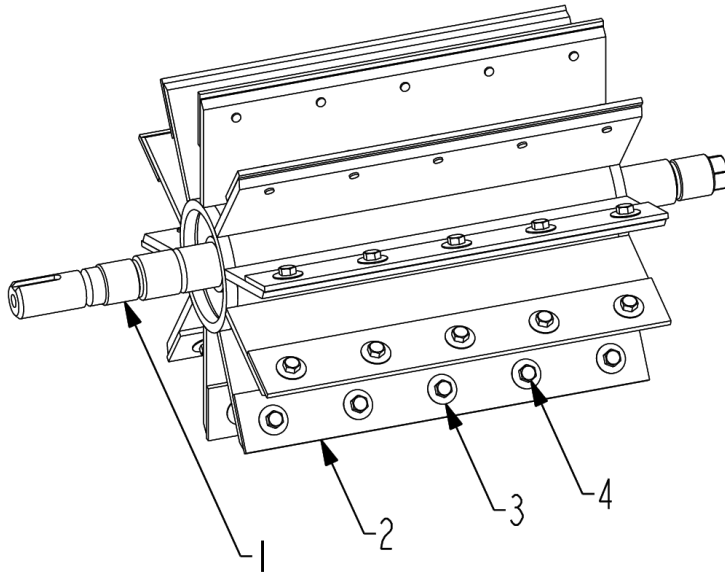

Model		Description	Part Number
A, B, C, D, F, I, J, L, O, P, R, T, U	1	ROTOR, 1314, ADJ TIPS	30-01831-5
E	1	ROTOR, 1314, V-RTR	30-110151-5
G, N, Q, V	1	ROTOR, 1314, ADJ TIPS, ABR	30-97431-5
H	1	ROTOR, 1314, BVL, ABR, SS	30-110004-5
K, M, S	1	ROTOR, 1314, ADJ TIPS, HXB	30-09032-5
A, C, F, I, J, L, O, P, R, T	2	TIP, 1314, HXS	30-65702-4
B, D, G, K, M, N, Q, S, U, V	2	TIP, 1314, HXB	30-64835-4
E	2	TIP, 1314, FLEX	30-70975-6
A, B, C, D, E, F, G, I, K, L, M, N, O, P, Q, R, S, T, U, V	3	BELLEVILLE WASHER, 1"	94-13003-6
E	3	WASHER PLATE, 1314, FLEX	30-70976-4
J	3	PLATE WASHER, 5/16, SS, A-N AND LOCK WASHER, 5/16, AA, A-N	94-08668-6 AND 94-08669-6
A, B, C, D, F, R	4	BOLT, 5/16-18-5/8, GR 8, NYL	94-61715-6
E, G	4	BOLT, 5/16-18-1, GR 8, PLTD	94-05284-6
I, K, M, O, P, Q, R, S, T, U, V	4	CAP SCREW, 5/16-18-1/2, TRX	94-08478-6
J	4	BOLT, 5/16-18-5/8, 18-8, SS	94-85804-6
L, N	4	CAP SCREW, 5/16-18-5/8, TRX	94-08781-6

DRIVEN END SHAFT COMPONENTS

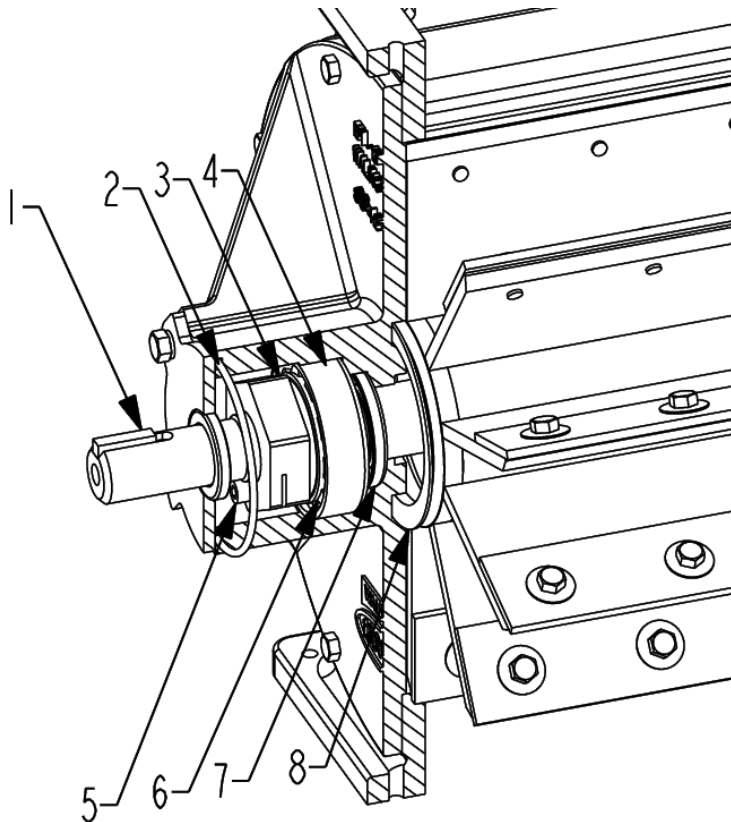

Model	Description		Part Number
A, B, C, D, E, F, G, H, I, J, K, L, M, N, O, P, Q, R, S, T, U, V	1	KEY, 5/16" x 5/16" x 1-1/4"	97-80191-6
	2	O-RING, 2-345, N70	96-01013-6
	3	LOCK NUT, 1-3/8", 1314	30-91304-4
	4	BEARING CUP, 3820	96-01032-6
	5	SET SCREW, 5/16-18-3/4, NYL	94-96975-6
	6	BEARING CONE, 3876	96-01034-6
A, B, C, D, E, I, J, K, L, M, O, P, R, S, T, U	7	SEAL, CR15142	96-00890-6
F, G, H, N, Q, V	7	OUTER SEAL, CR17558 AND INNER SEAL, AVT, S67350-0327L	96-00161-6 AND 96-15492-6
A, B, C, D, E, I, J, K, L, M, O, P, R, S, T, U	8	V-SEAL, TEXIN, 355D 1500	96-02027-6
F, G, N, Q, V	8	ROTOR SLEEVE, 1314, ABR	30-130037-4

IDLE END SHAFT COMPONENTS

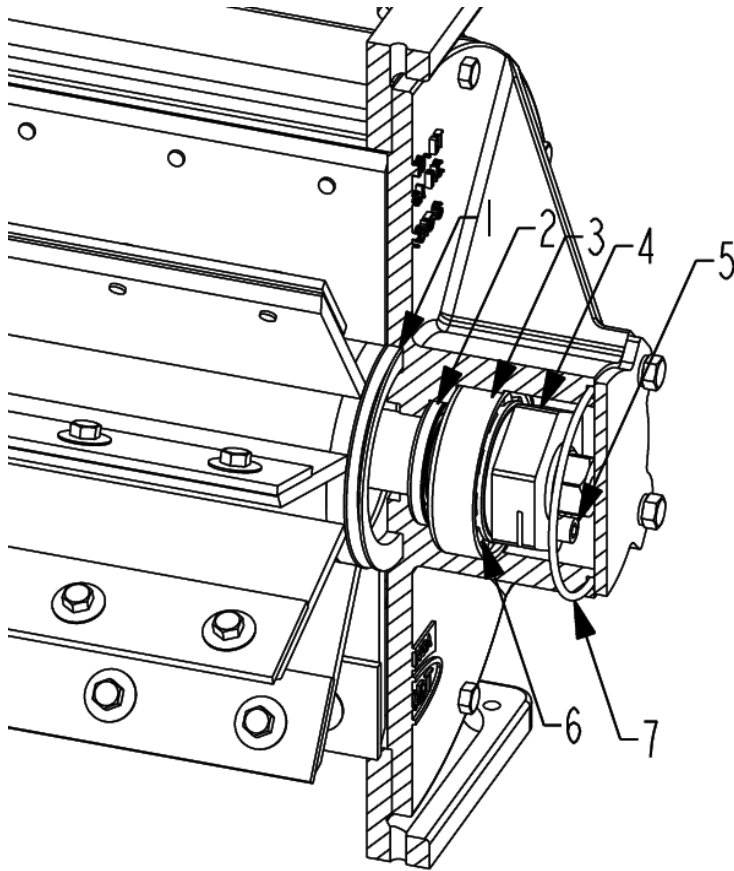

Model	Description		Part Number
A, B, C, D, E, I, J, K, L, M, O, P, R, S, T, U	1	V-SEAL, TEXIN, 355D 1500	96-02027-6
	2	SEAL, CR15142	96-00890-6
F, G, N, Q, V	1	ROTOR SLEEVE, 1314, ABR	30-130037-4
F, G, H, N, Q, V	2	OUTER SEAL, CR17558	96-00161-6
		INNER SEAL, AVT, S67350-0327L	AND 96-15492-6
A, B, C, D, E, F, G, H, I, J, K, L, M, N, O, P, Q, R, S, T, U, V	3	BEARING CUP, 3820	96-01032-6
	4	LOCK NUT, 1-3/8", 1314	30-91304-4
	5	SET SCREW, 5/16-18-3/4, NYL	94-96975-6
	6	BEARING CONE, 3876	96-01034-6
	7	O-RING, 2-345, N70	96-01013-6

MISCELLANEOUS

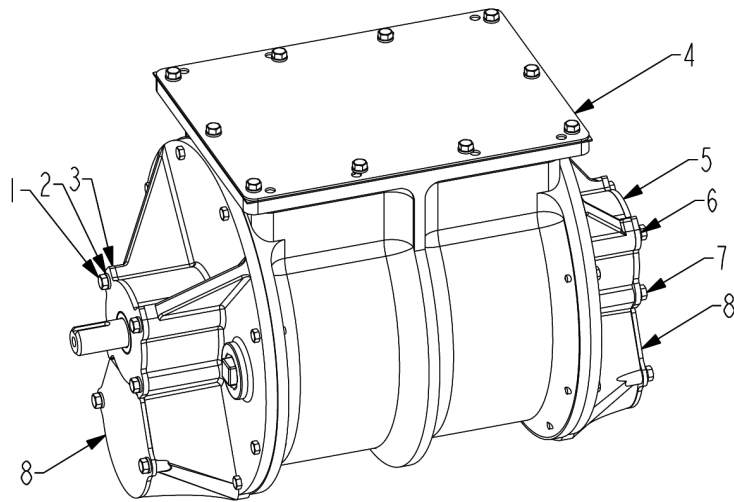

Model	Description		Part Number
A, B, C, D, E, F, G, H, I, J, K, L, M, N, O, P, Q, R, S, T, U, V	1	BOLT, 3/8-16-1 1/4, GR 8, PLTD	94-05318-6
	2	LOCK WASHER, 3/8", PLTD	94-04285-6
	3	SEAL PLATE, 1314	30-04531-5
	4	DEBRIS COVER PLATE, 1314, DT & BT INLET/DT OUTLET	30-106877-5
	5	DUST PLATE, 1314	30-09035-4
	6	LOCK WASHER, 3/8", PLTD	94-04285-6
	7	BOLT, 3/8-16-1, GR 8, PLTD	94-05317-6
I, J, K, L, M, N	8	DEBRIS COVER PLATE, 1314-4, OUTLET	30-38574-4
O, P, Q, R, S, T, U, V	8	DEBRIS COVER PLATE, 1314-5, OUTLET	30-38572-4



PAGE INTENTIONALLY LEFT BLANK



PAGE INTENTIONALLY LEFT BLANK

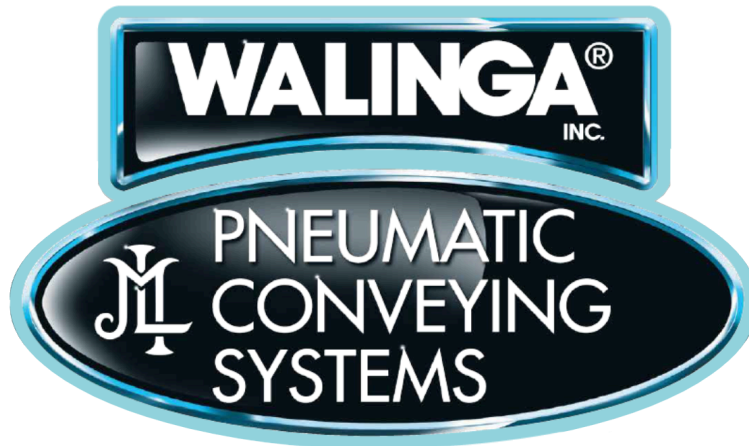

WALINGA[®]
INC.

CORPORATE HEAD OFFICE:

5656 Highway 6N
RR#5 Guelph, Ontario, N1H 6J2
PHONE (519) 824-8520
FAX (519) 824-5651
www.walinga.com

FACTORY DISTRIBUTION AND SERVICE CENTERS:

938 Glengarry Crescent
Fergus, ON, Canada, N1M 2W7
PHONE (519) 787-8227
FAX (519) 787-8210

70 3rd Avenue N.E. Box 1790
Carman, MB, Canada, R0G 0J0
PHONE (204) 745-2951
FAX (204) 745-6309

6116 46 St.
Bloomsbury, AB, Canada, T0G 0G0
PHONE (780) 572-6082

1190 Electric Avenue
Wayland, MI, USA, 49348
PHONE (800) 466-1197
FAX (616) 877-3474

579 4th St. NW
Sioux Center, IA, USA, 51250
PHONE (800) 845-5589
FAX (712) 722-1128

24 Molloy St.
Toowoomba, Qld, Australia, 4350
PHONE 07-4636-7344
EMAIL mail@customvac.com.au