

**AGRI-VAC
3510**

WALINGA[®]
INC.

Agri-Vac[®]



**OPERATOR'S MANUAL
and PARTS BOOK**

**Model 3510
Gas and Electric**

WALINGA[®]
TOUGH TO BEAT IN THE LONG RUN

3510 AGRIVAC -VAC MODELS GAS & ELECTRIC Warranty Registration Form & Inspection Report

WARRANTY REGISTRATION (3 part form - please print)		
<i>This form must be filled out by the dealer and signed by both the dealer and the customer at the time of delivery.</i>		
<i>Delivery Date: mm / dd / yyyy</i>		
<i>COMPANY / CUSTOMER NAME</i>		<i>DEALER NAME:</i>
<i>Phone:</i>		<i>Phone:</i>
<i>Mobile phone:</i>		<i>Mobile phone:</i>
<i>Email : @</i>		<i>Email : @</i>
<i>Street Address:</i>		<i>Street Address:</i>
<i>City: Prov/State</i>		<i>City: Prov/State:</i>
<i>Postal/Zip: Country</i>		<i>Postal/Zip: Country:</i>
<i>Machine Serial Number</i>	<i>Blower Serial No.</i>	<i>Airlock Serial Number</i>

DEALER INSPECTION REPORT		SAFETY	
<input type="checkbox"/>	Blowers and Airlock Turn Freely	<input type="checkbox"/>	Guards Installed and Secured
<input type="checkbox"/>	Air Line Connections Tight	<input type="checkbox"/>	All Safety Signs Installed
<input type="checkbox"/>	Check Tire Pressure	<input type="checkbox"/>	Reflectors and Signs Clean
<input type="checkbox"/>	Wheel Bolts Tight	<input type="checkbox"/>	Review Operating and Safety Instructions
<input type="checkbox"/>	Lubricate Machine	<input type="checkbox"/>	Operating Manual Supplied
<input type="checkbox"/>	Check Oil Level in Reservoirs		
<input type="checkbox"/>	Belts are Tight		
<input type="checkbox"/>	O-Rings in Place		

I have thoroughly instructed the buyer on the above described equipment which review included the Operator's Manual content, equipment care, adjustments, safe operation and applicable warranty policy.

Date _____ Dealer's Rep. Signature _____

The above equipment and Operator's Manual have been received by me and I have been thoroughly instructed as to care, adjustments, safe operation and applicable warranty policy.

Date _____ Owner's Signature _____

199 05042016

*3 Part Form
Please Print*

WHITE	YELLOW	PINK
WALINGA	DEALER	CUSTOMER

Walinga Inc.

Pneumatic Conveying System

Warranty Terms

Walinga Inc. is committed to providing a quality product that will meet or exceed your expectations for many years to come. Our warranty terms and our warranty claim process has been designed to ensure that each warranty claim will be resolved in an orderly, fair and timely manner.

The Warranty

Walinga Inc. ("Walinga") warrants that all new pneumatic products sold by Walinga Inc. will be free from defects in material and workmanship (the "Walinga Warranty").

Warranty Period

The warranty period for the Walinga Warranty shall expire on the date that is the earlier of: two (2) years after the date of delivery to the original customer; or upon the expiration of five hundred (500) hours of operation; whichever date comes first.

Limitations of and exclusions from the Walinga Warranty

- The Walinga Warranty applies to material and workmanship only.
- With respect to any component parts that are supplied or manufactured by others, the warranty coverage on such component parts will be strictly limited to the warranties of the manufacturers of such component parts.
- The Walinga Warranty shall only be for the benefit of the original purchaser of the pneumatic products.
- A Walinga Warranty may be transferable by the original purchaser to a third party for the balance of the warranty period then remaining, provided that Walinga consents in writing to such transfer of warranty.
- The Walinga Warranty is conditional upon proper storage, installation, use, maintenance, operation and compliance with any applicable recommendations of Walinga.

Warranty Claim Procedure

Should you encounter any difficulties with your unit within its warranty period, please contact your local Walinga dealer or sales representative, your local Walinga Service department or Walinga's Warranty Department to submit a warranty claim application.

To speak with a Walinga Warranty Coordinator, contact:

- Canada 1-888-WALINGA (ext 273)
International +1-519-824-8520 (ext 273)
Email – warranty.canada@walinga.com
- USA 1-800-466-1197 (ext 8)
Email – warranty.usa@walinga.com
- Australia 07-4634-7344
Email – mail@customvac.com.au

Required Warranty Claim information

The following information must be provided to Walinga in order for us to properly process and consider your warranty application:

- Customer name and contact information (email if available).
- The equipment serial number and/or Vehicle Identification Number (if applicable).
- Date of claimed failure.
- Equipment hours of operation.
- Details, description and photos (upon request) of the claimed failure and the corrective repairs attempted.

Warranty Conditions

- **Equipment must be registered within 30 days of being received by the buyer. It will be within the sole and unfettered discretion of Walinga as to whether it will honour its warranty on non-registered equipment.**

Warranty Conditions (continued)

- The buyer is responsible for promptly notifying Walinga of any defects to the equipment. The buyer is also responsible for making the equipment available to Walinga or its authorized repair facility for evaluation and repair.
- Prior to making any repairs or parts replacements, a warranty application and any estimated associated costs must be approved with the issuance of a claim number by an authorized Walinga representative. Undertaking any work prior to receiving warranty authorization may result in a partial or complete loss of warranty coverage.
- At Walinga's discretion, warranty repairs may be authorized to be completed at a repair facility convenient to the buyer. In such situations the estimated labour time must be approved by Walinga prior to undertaking any work. Labour hours will be reimbursed at the facilities posted hourly labour rate.
- At Walinga's request, parts in question must be returned to the nearest Walinga service facility for evaluation. In such situations a Returned Goods Authorization (RGA) number will be provided to the buyer. The returning shipment must be clearly labeled with the assigned RGA number and include a copy of the RGA form. Unless otherwise arranged, these parts are to be returned to Walinga within 30 days to ensure timely processing of your warranty claim. Failure to return such parts may result in partial or complete loss of warranty coverage.
- Replacement parts provided under warranty are covered for the remainder of the original equipment warranty period.
- Walinga reserves the right to use new, remanufactured or refurbished components when performing warranty repairs and replacements.
- Walinga is entitled to a reasonable amount of time and a reasonable number of attempts to assess the claim, diagnose the problem, and perform any necessary repairs.
- The warranty offered on used or refurbished equipment is limited to that specified on the purchase contract. Where a warranty period has not been stipulated on the purchase contract., and where such equipment is "used", then such equipment is considered by Walinga to be sold "as is, where is" without the Walinga Warranty. Where such equipment is refurbished, then the Walinga Warranty shall apply.

Without limitation, Walinga reserves the right to reject a warranty claim or for any one or more of the following reasons:

- The warranty claim information provided is insufficient.
- The product evaluation does not substantiate the claim.
- The unit has been operated above and beyond its capacity or not maintained or serviced properly, resulting in damages incurred to major components.
- If the unit was equipped with a factory installed hour meter which has been disconnected, altered or inoperative for an extended period of time; with the result being that the equipment's operating hours cannot be verified.
- It is apparent that the operator's manuals have not been followed.
- The equipment is not registered.

Without limitation, Walinga's Warranty does not cover:

- Damage or deterioration due to lack of reasonable care or maintenance.
- Damage caused or affected by unapproved modifications to the equipment.
- Damage caused by negligence or misuse of the equipment.
- Damage caused by using the equipment for purposes for which it was not designed or intended.

Walinga's liability under this warranty, whether in contract or tort, is limited to the repair, replacement or adjustment of defective materials and workmanship. In no event will Walinga be responsible for any direct, indirect, loss of time, incidental or consequential expenses including, but not limited to, equipment rental expenses, towing, downtime, inconvenience, or any losses resulting from the inability to use the equipment. Further, Walinga shall not be liable for any damages or inconvenience caused by any delay in the supply or delivery of any equipment or component parts thereof.

The selling Dealer/Sales Person makes no warranty of its own and has no authority to make any representation or promise on behalf of Walinga, or to modify the terms or limitations of the Walinga Warranty in any way.

Punitive, exemplary or multiple damages may not be recovered unless applicable law prohibits their disclaimer.

Warranty related claims may not be brought forward as a class representative, a private attorney general, a member of a class of claimants or in any other representative capacity.

The Walinga Warranty and all questions regarding its enforceability and interpretation are governed by the law of the country, state or province in which you purchased your Walinga equipment. The laws of some jurisdictions limit or do not allow the disclaimer of consequential damages. If the laws of such a jurisdiction apply to any claim against Walinga, the limitations and disclaimers contained here shall be to the greatest extent permitted by law.

Dear Customer,

Thank you for choosing WALINGA PNEUMATIC CONVEYING SYSTEMS. For your convenience, should you require any information related to Parts, Service or Technical Engineering, please contact one of the following Walinga Personnel in Guelph at 1-888 925-4642 unless noted

TECHNICAL - ENGINEERING:

Duane Swaving 226-979-8227 duane.swaving@walinga.com

Ken Swaving 519 787-8227 (ext:100) ks@walinga.com

WARRANTY CLAIMS:

Canada: Kevin Vanderzwaag (273) warranty@walinga.com

USA: Jonathan Medemblik (800) 466-1197 (ext 8) jtm@walinga.com

SERVICE MANAGER:

Andy Nijenhuis (519) 763-7000 (ext:260) andy@walinga.com

SALES MANAGER:

Canada: Tom Linde (519) 787-8227 (ext 5) thl@walinga.com

USA: Peter Kingma (800) 466-1197 jpk@walinga.com

ORIGINAL PARTS SALES:

Ontario and Eastern Canada:

Scott Lodder (ext: 224) spl@walinga.com

Parts Department Fax: (519) 824-0367

Manitoba and Western Canada:

Chad Yeo 204-745-2951 chad.yeo@walinga.com

USA: John VanMiddlekoop (800) 466-1197 (ext 3) jym@walinga.com

CORPORATE HEAD OFFICE:

5656 Highway 6N

RR#5, Guelph, Ontario, N1H 6J2

PHONE: (888) 925-4642 FAX: (519) 824-5651

www.walinga.com

AGRI-VAC MANUFACTURING FACILITY:

938 Glengarry Cres., Fergus, Ontario Canada N1M 2W7

Tel: (519) 787-8227 Fax: (519) 787-8210

DISTRIBUTION AND SERVICE CENTRES:

5656 Highway 6N, Guelph, Ontario Canada, N1H 6J2

Tel: (888) 925-4642 FAX: (519) 824-5651

1190 Electric Ave. Wayland , MI.USA 49348

Tel: (800) 466-1197 Fax: (616) 877-3474

70 3rd Ave. N.E. Box 1790 Carman, Manitoba Canada R0G 0J0

Tel: (204) 745-2951 Fax: (204) 745-6309

24 Molloy Street, Toowoomba, Queensland Australia 4350

Tel: 07-4634-7344 mail@customvac.com.au

SERIAL NUMBER LOCATION

Always give your dealer the serial numbers of your Walinga® Inc. Agri-Vac® when ordering parts or requesting service or other information.

Serial number plates are located where indicated. Please mark the numbers in the spaces provided for easy reference.



SERIAL NUMBER LOCATION

Airlock Serial Number

Machine Serial Number



Blower Serial Number

TABLE OF CONTENTS

SECTION	DESCRIPTION	PAGE
1	Introduction	1
2	Safety.....	2
2.1	General Safety	3
2.2	Equipment Safety Guidelines.....	4
2.3	Storage Safety	4
2.4	Safety Training.....	5
2.5	Safety Signs.....	5
2.6	Preparation.....	6
2.7	Installation Safety.....	6
2.8	Lock-Out Tag-Out Safety.....	6
2.9	Operating Safety	7
2.10	Maintenance Safety	7
2.11	Electrical Safety	8
2.12	Transport Safety.....	8
2.13	Refueling Safety.....	8
2.14	Tire Safety.....	8
2.15	Battery Safety.....	8
2.16	Gas Motor Safety	9
2.17	Safety Around Bins, Silos, Tanks etc.	10
2.18	Employee Sign-Off Form.....	11
3	Safety Sign Locations	13
4	Operation.....	17
4.1	To the New Operator or Owner	17
4.2	Machine Components	18
4.3	Machine Break-In.....	19
4.4	Pre-Operation Checklist	19
4.5	Machine Preparation	20
4.6	Controls.....	21
4.7	Field Operation.....	23
4.8	Transport.....	29
4.9	Storage.....	30
4.10	Conveying Oilseeds.....	30
5	Service and Maintenance	31
5.1	Service.....	31
5.2	Maintenance.....	37
6	Trouble Shooting	49
7	Specifications	53
7.1	Mechanical.....	53
7.2	Bolt Torque	54
8	Parts	55
9	Index	57

1 INTRODUCTION

Congratulations on your choice of a Walinga® Agri-Vac® to complement your operation. This equipment has been designed and manufactured to meet the needs of the discriminating buyer for the efficient moving of grain.

Safe, efficient and trouble free operation of your new Walinga® Agri-Vac® requires that you, and anyone else who will be operating or maintaining the Agri-Vac®, read, understand and practice ALL of the Safety, Operation, Maintenance and Trouble Shooting recommendations contained within this Operator's Manual.



This manual applies to the Walinga® 3510 gas or electric Agri-Vac®. Use the Table of Contents and Index as a guide to find required information.

OPERATOR ORIENTATION - The directions left, right, front and rear as mentioned throughout this manual are when viewed from the airlock end of the machine. The steering handle is the front, drive system left and airlock rear.

2 SAFETY

SAFETY ALERT SYMBOL

This Safety Alert symbol means
ATTENTION! BECOME ALERT! YOUR
SAFETY IS INVOLVED!

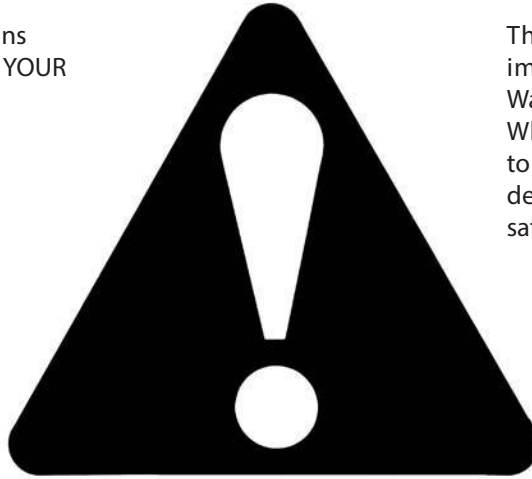

The Safety Alert symbol identifies important safety messages on the Walinga® Agri-Vac® and in the manual. When you see this symbol, be alert to the possibility of personal injury or death. Follow the instructions in the safety message.

Why is SAFETY important to you?

3 Big Reasons

Accidents Disable and Kill
Accidents Cost
Accidents Can Be Avoided

SIGNAL WORDS:

Note the use of the signal words DANGER, WARNING and CAUTION with the safety messages. The appropriate signal word for each message has been selected using the following guide-lines:

DANGER - Indicates an imminently hazardous situation that, if not avoided, will result in death or serious injury. This signal word is to be limited to the most extreme situations typically for machine components which, for functional purposes, cannot be guarded.

WARNING - Indicates a potentially hazardous situation that, if not avoided, could result in death or serious injury, and includes hazards that are exposed when guards are removed. It may also be used to alert against unsafe practices.

CAUTION - Indicates a potentially hazardous situation that, if not avoided, may result in minor or moderate injury. It may also be used to alert against unsafe practices.

Keep this manual handy for frequent reference and to pass on to new operators or owners. Call your Walinga® dealer if you need assistance, information or additional copies of the manual. Contact your dealer for a complete listing of parts.





SAFETY

YOU are responsible for the SAFE operation and maintenance of your Walinga® Agri-Vac®. YOU must ensure that you and anyone else who is going to operate, maintain or work around the Agri-Vac® be familiar with the operating and maintenance procedures and related SAFETY information contained in this manual. This manual will take you step-by-step through your working day and alerts you to all good safety practices while operating the Agri-Vac®.

Remember, YOU are the key to safety. Good safety practices not only protect you but, also the people around you. Make these practices a working part of your safety program. Be certain that EVERYONE operating this machine is familiar with the procedures recommended and follows safety precautions. Remember, most accidents can be prevented. Do not risk injury or death by ignoring good safety practices.

- Agri-Vac® owners must give operating instructions to operators or employees before allowing them to operate the machine, and at least annually thereafter.
- The most important safety device on this equipment is a SAFE operator. It is the operator's responsibility to read and understand ALL Safety and Operating instructions in the manual and to follow these. Most accidents can be avoided.
- A person who has not read and understood all operating and safety instructions is not qualified to operate this machine. An untrained operator exposes himself and bystanders to possible serious injury or death.
- Do not modify the equipment in any way. Unauthorized modification may impair the function and/or safety and could affect the life of the equipment.
- Think SAFETY! Work SAFELY!

2.1 GENERAL SAFETY

1. Read and understand the Operator's Manual and all safety signs before supplying power, operating, maintaining, adjusting or unplugging. 
2. Only trained, competent persons shall operate the Agri-Vac®. An untrained operator is not qualified to operate this machine.
3. Provide a first-aid kit for use in case of an accident. Store in a highly visible place. 
4. Provide a fire extinguisher for use in case of an accident. Store in a highly visible place. 
5. Install and properly secure all guards and shields before operating.
6. Wear appropriate protective gear. This list includes but is not limited to:
 - A hard hat
 - Protective shoes with slip resistant soles
 - Protective glasses or goggles
 - Heavy gloves
 - Wet weather gear
 - Hearing protection
7. Turn machine OFF, shut down and lockout power supply and wait for all moving parts to stop before servicing, adjusting, maintaining, repairing, cleaning or unplugging. (Safety lockout devices are available through your Walinga® dealer parts department).
8. Know the emergency medical center number for your area.
9. Wear appropriate hearing protection when operating the machine.
10. Review safety related items with all operators annually.

2.2 EQUIPMENT SAFETY GUIDELINES

1. Safety of the operator and bystanders is one of the main concerns in designing and developing a machine. However, every year many accidents occur which could have been avoided by a few seconds of thought and a more careful approach to handling equipment. You, the operator, can avoid many accidents by observing the following precautions in this section. To avoid personal injury or death, study the following precautions and insist those working with you, or for you, follow them.
2. In order to provide a better view, certain photographs or illustrations in this manual may show an assembly with a safety shield removed. However, equipment should never be operated in this condition. Keep all shields in place. If shield removal becomes necessary for repairs, replace the shield prior to use.
3. Replace any safety sign or instruction sign that is not readable or is missing. Location of such safety signs is indicated in this manual.
4. Never use alcoholic beverages or drugs which can hinder alertness or coordination while operating this equipment. Consult your doctor about operating this machine while taking prescription medications.
5. Under no circumstances should young children be allowed to work with this equipment. Do not allow persons to operate or assemble this unit until they have read this manual and have developed a thorough understanding of the safety precautions and of how it works. Review the safety instructions with all users annually.
6. This equipment is dangerous to children and persons unfamiliar with its operation. The operator should be a responsible, properly trained and physically able person familiar with farm machinery and trained in this equipment's operations. If the elderly are assisting with farm work, their physical limitations need to be recognized and accommodated.
7. Never exceed the limits of a piece of machinery. If its ability to do a job, or to do so safely, is in question - DON'T TRY IT.
8. Do not modify the equipment in any way. Unauthorized modification result in serious injury or death and may impair the function and life of the equipment.

9. In addition to the design and configuration of this implement, including Safety Signs and Safety Equipment, hazard control and accident prevention are dependent upon the awareness, concern, prudence, and proper training of personnel involved in the operation, transport, maintenance, and storage of the machine. Refer also to Safety Messages and operation instruction in each of the appropriate sections of the auxiliary equipment and machine Manuals. Pay close attention to the Safety Signs affixed to the auxiliary equipment and the machine.

2.3 STORAGE SAFETY

1. Store the Agri-Vac® on a firm level surface.
2. If required, make sure the unit is firmly blocked up.
3. Make certain that all mechanical locks are safely and positively connected before storing.
4. Store away from areas of human activity.
5. Do not allow children to play on or around the stored Agri-Vac®.
6. Lock out power by turning off master control panel or junction box and padlocking the door shut to prevent electrocution or unauthorized start up of the Agri-Vac® for the electric model.
7. Stop engine, remove ignition key and store in a secure place for the gas model.

2.4 SAFETY TRAINING

1. Safety is a primary concern in the design and manufacture of our products. Unfortunately, our efforts to provide safe equipment can be wiped out by a single careless act of an operator or bystander.
2. In addition to the design and configuration of equipment, hazard control and accident prevention are dependent upon the awareness, concern, prudence and proper training of personnel involved in the operation, transport, maintenance and storage of this equipment.
3. It has been said, "The best safety feature is an informed, careful operator." We ask you to be that kind of an operator.  It is the operator's responsibility to read and understand ALL Safety and Operating instructions in the manual and to follow these. Accidents can be avoided.
4. Working with unfamiliar equipment can lead to careless injuries. Read this manual, and the manual for your auxiliary equipment, before assembly or operating, to acquaint yourself with the machines. If this machine is used by any person other than yourself. It is the machine owner's responsibility to make certain that the operator, prior to operating:
 - a. Reads and understands the operator's manuals.
 - b. Is instructed in safe and proper use.
5. Know your controls and how to stop the Agri-Vac® and any other auxiliary equipment quickly in an emergency. Read this manual and the one provided with your other equipment.
6. Train all new personnel and review instructions frequently with existing workers. Be certain only a properly trained and physically able person will operate the machinery. A person who has not read and understood all operating and safety instructions is not qualified to operate the machine. An untrained operator exposes himself and bystanders to possible serious injury or death. If the elderly are assisting with work, their physical limitations need to be recognized and accommodated.

2.5 SAFETY SIGNS

1. Keep safety signs clean and legible at all times.
2. Replace safety signs that are missing or have become illegible.
3. Replaced parts that displayed a safety sign should also display the current sign.
4. Safety signs are available from your authorized Distributor or Dealer Parts Department or the factory.

How to Install Safety Signs:

- Be sure that the installation area is clean and dry.
- Be sure temperature is above 50°F (10°C).
- Determine exact position before you remove the backing paper. (See Section 3).
- Remove the smallest portion of the split backing paper.
- Align the sign over the specified area and carefully press the small portion with the exposed sticky backing in place.
- Slowly peel back the remaining paper and carefully smooth the remaining portion of the sign in place.
- Small air pockets can be pierced with a pin and smoothed out using the piece of sign backing paper.

2.6 PREPARATION

1. Never operate the Agri-Vac® and auxiliary equipment until you have read and completely understand this manual, the auxiliary equipment Operator's Manual, and each of the Safety Messages found on the safety signs on the and auxiliary equipment.

2. Personal protection equipment including hard hat, safety glasses, safety shoes, and gloves are recommended during assembly, installation, operation, adjustment, maintaining, repairing, removal, or moving the implement. Do not allow long hair, loose fitting clothing or jewelry to be around equipment.



3. **PROLONGED EXPOSURE TO LOUD NOISE MAY CAUSE PERMANENT HEARING LOSS!** Motors or equipment attached can often be noisy enough to cause permanent, partial hearing loss. We recommend that you wear hearing protection on a full-time basis if the noise in the Operator's position exceeds 80db. Noise over 85db on a long-term basis can cause severe hearing loss. Noise over 90db adjacent to the Operator over a long-term basis may cause permanent, total hearing loss. NOTE: Hearing loss from loud noise (from tractors, chain saws, radios, and other such sources close to the ear) is cumulative over a lifetime without hope of natural recovery.
4. Clear working area of debris, trash or hidden obstacles that might be hooked or snagged, causing injury, damage or tripping.
 5. Operate only in daylight or good artificial light.
 6. Be sure machine is properly anchored, adjusted and in good operating condition.
 7. Ensure that all safety shielding and safety signs are properly installed and in good condition.
 8. Before starting, give the machine a "once over" for any loose bolts, worn parts, cracks, leaks, frayed belts and make necessary repairs. Always follow maintenance instructions.



2.7 INSTALLATION SAFETY

1. Disconnect and remove all mechanical locks, anchor chains and any other transport devices that would hinder or prohibit the normal functioning of the Agri-Vac® upon start up. Serious damage to the machine and/or personal injury to the operator and bystanders may result from attempting to operate the machine while mechanical locking devices are still attached.
2. Position the machine on firm, level ground before operating.
3. Level the frame before using or loading.
4. Have at least one extra person available to assist when elevating, moving or connecting to other equipment.
5. Make certain that sufficient amperage, at the proper voltage and frequency (60Hz) is available before connecting power for the electric model. Have a licensed electrician provide power to the machine. Always follow ANSI/NFPA 70 Standard and all local codes when providing electrical power.
6. If using Agri-Vac® as part of grain handling system, anchor securely before starting.
7. Attach exhaust piping to engine or good cross ventilation to the outside if operating the gas model inside a building or enclosed area.

2.8 LOCK-OUT TAG-OUT SAFETY

1. Establish a formal Lock-Out Tag-Out program for your operation.
2. Train all operators and service personnel before allowing them to work around the Agri-Vac®.
3. Provide tags at the work site and a sign-up sheet to record tag out details.
4. Do not perform any service or maintenance work unless motor and engine are OFF and the power locked out.

2.9 OPERATING SAFETY

1. Read and understand the Operator's Manual and all safety signs before operating, maintaining, adjusting or repairing the Agri-Vac®.
2. Before servicing, adjusting, repairing or maintaining unit, ensure that unit power source is completely shut down and can not start up.
3. Do not operate when any guards are damaged or removed, Install and secure guards before starting.
4. Keep hands, feet, clothing and hair away from all moving and/or rotating parts.
5. Clear the area of all bystanders, especially small children, before starting.
6. Before supplying electrical power to the machine, be sure you have adequate amperage at the proper phase and voltage to run it. If you do not know or are unsure, consult a licensed electrician.
7. Clean reflectors, SMV signs and lights before transporting.
8. Wear appropriate ear protection when operating machine.
9. Do not place intake nozzle near feet when standing on the top of grain.



10. Review safety instructions annually.

2.10 MAINTENANCE SAFETY

1. Good maintenance is your responsibility. Poor maintenance is an invitation to trouble. Follow all operating, maintenance and operating instructions in this manual.

2. Follow good shop practices:

- Keep service area clean and dry.
- Be sure electrical outlets and tools are properly grounded.
- Use adequate light for the job at hand.

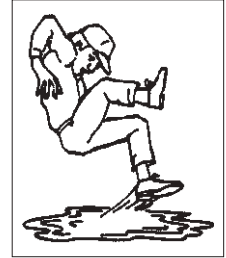

3. Make sure there is plenty of ventilation. Never operate the engine of the gas model in a closed building. The exhaust fumes may cause asphyxiation.
4. Before working on this machine, stop engine or motor and remove ignition key (gas) or turn power off at the master panel (electric). Lock-out tag-out machine.
5. Never work under equipment unless it is blocked securely. Only use tools, jacks and hoists of sufficient capacity for the job.
6. Always use personal protection devices such as eye, hand and hearing protectors, when performing any service or maintenance work.

7. A fire extinguisher and first aid kit should be kept readily accessible while performing maintenance on this equipment.



8. Periodically tighten all bolts, nuts and screws and check that all electrical and hydraulic connections are properly secured to ensure unit is in a safe condition.
9. When completing a maintenance or service function, make sure all safety shields and devices are installed before placing unit in service.

2.11 ELECTRICAL SAFETY

1. Have only a qualified licensed electrician supply power to the electric model by following ANSI/NFPA 70 Wiring Standard.
2. Make certain that the Agri-Vac® is properly grounded at the power source.
3. Make certain that all electrical switches are in the OFF position before plugging the Agri-Vac® in.
4. Turn machine OFF, shut down and lock out power supply (safety lockout devices are available through your Walinga® dealer parts department) and wait for all moving parts to stop before servicing, adjusting, maintaining or repairing.
5. Disconnect power before resetting any motor or breaker overload.
6. Replace any damaged electrical plugs, cords, switches and components immediately.
7. Do not work on Agri-Vac® electrical system unless the power cord is unplugged or the power supply is locked-out tagged-out.



2.12 TRANSPORT SAFETY

1. Comply with state and local laws governing safety and transporting of machinery on public roads.
2. Mount a lighting bar on the rear of the frame (when transporting on public roads) and connect to tow unit.
3. Check that all the lights, reflectors and other lighting requirements are installed and in good working condition.
4. Disconnect grain and vacuum lines and plug before transporting.
5. Do not drink and operate.

2.13 REFUELING SAFETY

1. Handle fuel with care. It is highly flammable.
2. Allow engine to cool for 5 minutes before refuelling. Clean up spilled fuel before restarting engine.
3. Do not refuel the machine while smoking or when near open flame or sparks.
4. Fill fuel tank outdoors.
5. Prevent fires by keeping machine clean of accumulated trash, grease and debris.



2.14 TIRE SAFETY

1. Failure to follow proper procedures when mounting a tire on wheel or rim can produce an explosion which may result in serious injury or death.
2. Do not attempt to mount a tire unless you have the proper equipment and experience to do the job.
3. Have a qualified tire dealer or repair service perform required tire maintenance.
4. When replacing worn tires, make sure they meet the original tire specifications. Never undersize.

2.15 BATTERY SAFETY

1. Keep all sparks and flames away from batteries as gas given off by the electrolyte is explosive.
2. Avoid contact with battery electrolyte: wash off spilled electrolyte immediately.
3. Wear safety glasses when working near batteries.
4. Do not tip batteries more than 45° to avoid electrolyte loss.
5. To avoid injury from spark or short circuit, disconnect battery ground cable before servicing any part of the electrical system.

2.16 GAS MOTOR SAFETY

BEFORE STARTING ENGINE, READ AND UNDERSTAND THE OPERATING AND MAINTENANCE INSTRUCTIONS THAT CAME WITH YOUR ENGINE.

WARNING: DO NOT

1. DO NOT run engine in an enclosed area. Exhaust gases contain carbon monoxide, an odorless and deadly poison.
2. DO NOT place hands or feet near moving or rotating parts.
3. DO NOT store, spill, or use gasoline near an open flame, or devices such as a stove, furnace, or water heater which use a pilot light or devices which can create a spark.
4. DO NOT refuel indoors where area is not well ventilated. Outdoor refuelling is preferred.
5. DO NOT refuel while engine is running. Allow engine to cool for 5 minutes before refuelling. Store fuel in approved safety containers.
6. DO NOT remove fuel tank cap while engine is running.
7. DO NOT operate engine if gasoline is spilled. Move machine away from the spill and avoid creating any ignition until gasoline has evaporated.
8. DO NOT smoke while filling fuel tank.
9. DO NOT choke carburetor to stop engine. Whenever possible, gradually reduce engine speed before stopping.
10. DO NOT run engine above rated speeds. This may result in injury.
11. DO NOT tamper with governor springs, governor links or other parts which may increase the governed speed.
12. DO NOT tamper with the engine speed selected by the original equipment manufacturer.
13. DO NOT check for spark with spark plug or spark plug wire removed.
14. DO NOT crank engine with spark plug removed. If engine is flooded, crank until engine starts.
15. DO NOT strike flywheel with a hard object or metal tool as this may cause flywheel to shatter in operation. Use proper tools to service engine.

16. DO NOT operate engine without a muffler. Inspect periodically and replace, if necessary. If engine is equipped with a muffler deflector, inspect periodically and replace, if necessary with correct deflector.
17. DO NOT operate engine with an accumulation of grass, leaves, dirt or other combustible materials in the muffler area.
18. DO NOT use this engine on any forest covered, brush covered, or grass covered unimproved land unless a spark arrester is installed on the muffler. The arrester must be maintained in effective working order by the operator. In the state of California the above is required by law (Section 4442 of the California Public Resources Code). Other states may have similar laws. Federal laws apply on federal land.
19. DO NOT touch hot muffler, cylinder or fins because contact may cause burns.
20. DO NOT run engine with air cleaner or air cleaner cover removed.

WARNING: DO

1. ALWAYS DO remove the wire from the spark plug when servicing the engine or equipment to prevent accidental starting. Disconnect the negative wire from the battery terminal if equipped with a 12 volt starting system.
2. DO keep cylinder fins and governor parts free of grass and other debris which can affect engine speed.
3. DO examine muffler periodically to be sure it is functioning effectively. A worn or leaking muffler should be repaired or replaced as necessary.
4. DO use fresh gasoline. Stale fuel can gum carburetor and cause leakage.
5. DO check fuel lines and fittings frequently for cracks or leaks. Replace if necessary.

2.17 SAFETY AROUND BINS,SILOS, TANKS AND BOOT PITS

Working in and around bins, silos, and tanks and boot pits.

Agri-Vac operators and all other personnel assisting should strictly adhere to the procedures outlined below before entering a storage structure. For additional details regarding these procedures, reference OSHA Standards, or your local regulations. (see also Sect 4.10.1)



Entering a bin, silo, tank or other type of storage structure is hazardous. You can suffocate and die from the materials stored inside these structures. There also may be explosive, harmful or poisonous gas or dust in the air.

Before entering a storage structure, a Agri-Vac operator and all other personnel assisting should strictly adhere to safety procedures as follows: *(adapted from the Kansas Grain and Feed Association's Safety, Health and Environment Committee.)*

1. The machine operator(s) and all assisting personnel should be aware of the actions they will take in the event of an emergency.
2. The machine operator(s) and all assisting personnel should be trained in the general and specific safety hazards associated with their work tasks.
3. The machine operator(s) and all assisting personnel should be trained in the general procedures and safety practices for entering and working in bins, silos, tanks or other storage structures, as well as the safety procedures for handling special tasks concerning entering and working in such structures.
4. The atmosphere within a bin, silo, tank or storage structure should be tested for the presence of combustible gases, dusts, vapors and toxic agents.
5. Ventilation should be provided until the unsafe conditions are eliminated or as long as there is a possibility of recurrence of the unsafe conditions while the bin, silo, tank or storage structure is occupied by personnel.
- 6. Anyone entering the bin, silo, tank, storage structure or boot pit, should wear an appropriate respirator and protective clothing, as long as there is a possibility of any unsafe atmospheric condition.**
7. When entering bins, silos, tanks or storage structures from the top, personnel should wear a body harness with lifeline, or use a boatswain's chair.
8. An observer equipped to provide assistance and trained in rescue procedures, including notification methods, should be stationed outside the bin, silo, tank or storage structure being entered. Visual, voice or signal line communications should be constantly maintained between the observer and the party in the bin, silo, tank or storage structure.
9. Equipment for rescue operations which is specifically suited for the bin, silo, tank or storage structure being entered should be provided.
10. Do not enter bins, silos, tanks or storage structures under a bridging condition, or where a buildup of materials could fall and bury you. It is also recommended that you do not walk or stand on grain or other materials where the depth is greater than waist high.
11. Be aware of the extremely high suction at the intake nozzle. Stay away from nozzle intake area.

3 SAFETY SIGN LOCATIONS

The types of safety signs and locations on the equipment are shown in the illustrations that follow. Good safety requires that you familiarize yourself with the various Safety Signs, the type of warning and the area, or particular function related to that area, that requires your SAFETY AWARENESS.

- Think SAFETY! Work SAFELY!



A



CAUTION

- Read Operator's Manual before using machine. 
- Stop engine or motor, remove ignition key or lock-out tag-out electrical power and wait for all moving parts to stop before servicing, adjusting, repairing, unplugging or fitting.
- Install and secure all guards before starting.
- Keep hands, feet, hair and clothing away from moving parts.
- Keep all air and grain lines, fittings and couplers tight and free of leaks before starting.
- Review safety instructions with all operators annually.

B



WARNING



**ROTATING AIRLOCK BLADES HAZARD
KEEP AWAY**

To prevent serious injury or death:

- Stop engine or motor, remove ignition key or lock-out tag-out electrical power and wait for all moving parts to stop before servicing, adjusting, repairing, unplugging or fitting.
- Keep hands, feet, hair and clothing away from moving parts.

REMEMBER - If Safety Signs have been damaged, removed, become illegible or parts replaced without safety signs, new signs must be applied. New safety signs are available from your authorized dealer.

The types of safety signs and locations on the equipment are shown in the illustrations that follow. Good safety requires that you familiarize yourself with the various Safety Signs, the type of warning and the area, or particular function related to that area, that requires your SAFETY AWARENESS.

- Think SAFETY! Work SAFELY!



C

WARNING

ROTATING PART HAZARD
To prevent serious injury or death:

- Close and secure all guards before operating.
- Stop engine or motor, remove ignition key or lock-out tag-out electrical power and wait for all moving parts to stop before servicing, adjusting, repairing, unplugging or fitting.
- Keep hands, feet, hair and clothing away from moving parts..

D

DANGER

GUARD MISSING
When this is visible
DO NOT OPERATE
ENTANGLEMENT HAZARD
can cause Serious Injury or Death

E

DANGER

ELECTRO-STATIC HAZARD
To prevent serious injury or death from electro-static discharge:

- Make sure conveying lines and work area are dust and fire hazard free.
- Use original equipment / hoses only.
- Stay well away from power lines. Do not use plastic hoses / piping unless they are properly grounded.

REMEMBER - If Safety Signs have been damaged, removed, become illegible or parts replaced without safety signs, new signs must be applied. New safety signs are available from your authorized dealer.

The types of safety signs and locations on the equipment are shown in the illustrations that follow. Good safety requires that you familiarize yourself with the various Safety Signs, the type of warning and the area, or particular function related to that area, that requires your SAFETY AWARENESS.

- Think SAFETY! Work SAFELY!



F

SHUT DOWN PROCEDURE

1. PULL NOZZLE OUT OF GRAIN
2. STOP THE AIRLOCK
3. SHUT OFF THE ENGINE

G

! DANGER

Do not place intake tube near feet when standing on top of material. Sufficient material can be removed to draw operator and intake tube into grain. Submersion in grain can cause suffocation.

! DANGER

ELECTRO-STATIC HAZARD
To prevent serious injury or death from electro-static discharge:

- Make sure conveying lines and work area are dust and fire hazard free.
- Use original equipment / hoses only.
- Do not use plastic hoses and / or piping, unless those are properly grounded.

IF MACHINE PULSATES EXCESSIVELY, OPEN SLIDE FOR MORE AIR.

REMEMBER - If Safety Signs have been damaged, removed, become illegible or parts replaced without safety signs, new signs must be applied. New safety signs are available from your authorized dealer.

The types of safety signs and locations on the equipment are shown in the illustrations that follow. Good safety requires that you familiarize yourself with the various Safety Signs, the type of warning and the area, or particular function related to that area, that requires your SAFETY AWARENESS.

- Think SAFETY! Work SAFELY!



H



I



REMEMBER - If Safety Signs have been damaged, removed, become illegible or parts replaced without safety signs, new signs must be applied. New safety signs are available from your authorized dealer.

4 OPERATION



OPERATING SAFETY

- Read and understand the Operator's Manual and all safety signs before operating, maintaining, adjusting or repairing the Agri-Vac®.
- Before servicing, adjusting, repairing or maintaining unit, ensure that unit power source is completely shut down and can not start up.
- Do not operate when any guards are damaged or removed, Install and secure guards before starting.
- Keep hands, feet, clothing and hair away from all moving and/or rotating parts.
- Clear the area of all bystanders, especially small children, before starting.
- Before supplying electrical power to the machine, be sure you have adequate amperage at the proper phase and voltage to run it. If you do not know or are unsure, consult a licensed electrician.
- Wear appropriate ear protection when operating machine.
- Do not place intake nozzle near feet when standing on the top of grain.
- Do not smoke while refueling.
- Do not place intake tube near feet when standing on top of material.
- Review safety instructions annually.

4.1 TO THE NEW OPERATOR OR OWNER

The Walinga® Agri-Vac® is designed to vacuum up grain and move it in a stream of pressurized air. A high capacity air pump moves the air through the machine creating a vacuum on the intake side and pressure on the outlet side. Be familiar with all operating and safety procedures before starting.

In addition to the design and configuration of equipment, hazard control and accident prevention are dependent upon the awareness, concern, prudence and proper training of personnel involved in the operation, transport, maintenance and storage of this equipment.

It is the responsibility of the owner or operator to read this manual and to train all other operators before they start working with the machine. Follow all safety instructions exactly. Safety is everyone's business. By following recommended procedures, a safe working environment is provided for the operator, bystanders and the area around the worksite. Untrained operators are not qualified to operate the machine.

Many features incorporated into this machine are the result of suggestions made by customers like you. Read this manual carefully to learn how to operate the machine safely and how to set it to provide maximum efficiency. By following the operating instructions in conjunction with a good maintenance program, your Agri-Vac® will provide many years of trouble-free service.

4.2 MACHINE COMPONENTS

The air pump or blower is the key component in the Agri-Vac[®] and is driven by the:

- 1) gasoline engine or
- 2) electric motor

through a belt and chain drive system. The blower moves air through the machine. On the intake side, the blower creates a vacuum in the receiver tank and intake lines for picking up grain. Grain is separated from the stream of air in the receiver tank.

On the discharge side of the blower, the pressurized air flows through the airlock where it picks up a metered quantity of grain and moves it out the lines to the discharge cyclone.

The airlock is rotated by the same power source as the blower.

- | | | | |
|---|------------------|---|------------------|
| A | Blower | G | Intake Port |
| B | Airlock | H | Nozzles |
| C | Receiver Tank | J | Drive Belts |
| D | Gas Engine | K | Drive Chain |
| E | Electric Motor | L | Lines |
| F | Discharge Outlet | M | Electric Control |



FIG. 1 MACHINE COMPONENTS

4.3 MACHINE BREAK-IN

Although there are no operational restrictions on the Agri-Vac® when used for the first time, it is recommended that the following mechanical items be checked:

- A. After operating for 1/2 hour:
 - 1. Turn blower and airlock by hand. Be sure they turn freely.
 - 2. Retorque all fasteners and hardware.
 - 3. Check the drive system. Re-tighten and re-align as required.
 - 4. Check for oil leaks. Stop leaks before continuing.
 - 5. Check gas engine fluid levels if so equipped.
 - 6. Check oil level in blower reservoirs. Add as required.
 - 7. Lubricate all grease fittings.
- B. After operating for 10 hrs:
 - 1. Turn blower by hand. Be sure that it turns freely.
 - 2. Retorque all fasteners and hardware.
 - 3. Check the drive system. Re-tighten and re-align as required.
 - 4. Check for oil leaks. Stop leaks before continuing.
 - 5. Check gas engine fluid levels if so equipped.
 - 6. Check oil level in blower reservoirs. Add as required.
 - 7. Then go to the normal servicing and maintenance schedule as defined in the Maintenance Section.

4.4 PRE-OPERATION CHECKLIST

Efficient and safe operation of the Walinga® Agri-Vac® requires that each operator reads and understands the operating procedures and all related safety precautions outlined in this section. A pre-operation checklist is provided for the operator. It is important for both the personal safety and maintaining the good mechanical condition of the Agri-Vac® that this checklist is followed.

Before operating the Agri-Vac® and each time thereafter, the following areas should be checked off:

- 1. Lubricate the machine per the schedule outlined in Section 5 Service and Maintenance.
- 2. Check gas engine fluid levels if so equipped.
- 3. Check the oil level in the blower reservoirs.
- 4. Check the tires and ensure that they are inflated to the specified pressure.
- 5. Check that the blower and airlock turn freely.
- 6. Close and secure all guards.

4.5 MACHINE PREPARATION

Before the Agri-Vac® can be used it must be set up and prepared for operation.

When setting-up, follow this procedure:

1. Clear the area of bystanders, especially small children.
2. Be sure you select a spot that has sufficient space to locate the machine and allows you to move around the unit to access the controls.
3. Block the wheels to prevent movement.
4. Remove the plugs from the receiver tank inlet and airlock outlet.
5. Connect the 12 foot suction and discharge lines.

NOTE
Ensure couplings have gaskets properly installed.

6. Reverse the above procedure when finished working and placing into storage.

WARNING

When emptying any bin or silo, use extreme caution before opening any lower access door. Grain can be bridged in the upper portion of the structure and collapse at any time. If this occurs with an open access door, you may get buried even when standing outside the structure in close proximity to the access door. Always confirm that grain is not bridged in the structure before opening any lower access doors.

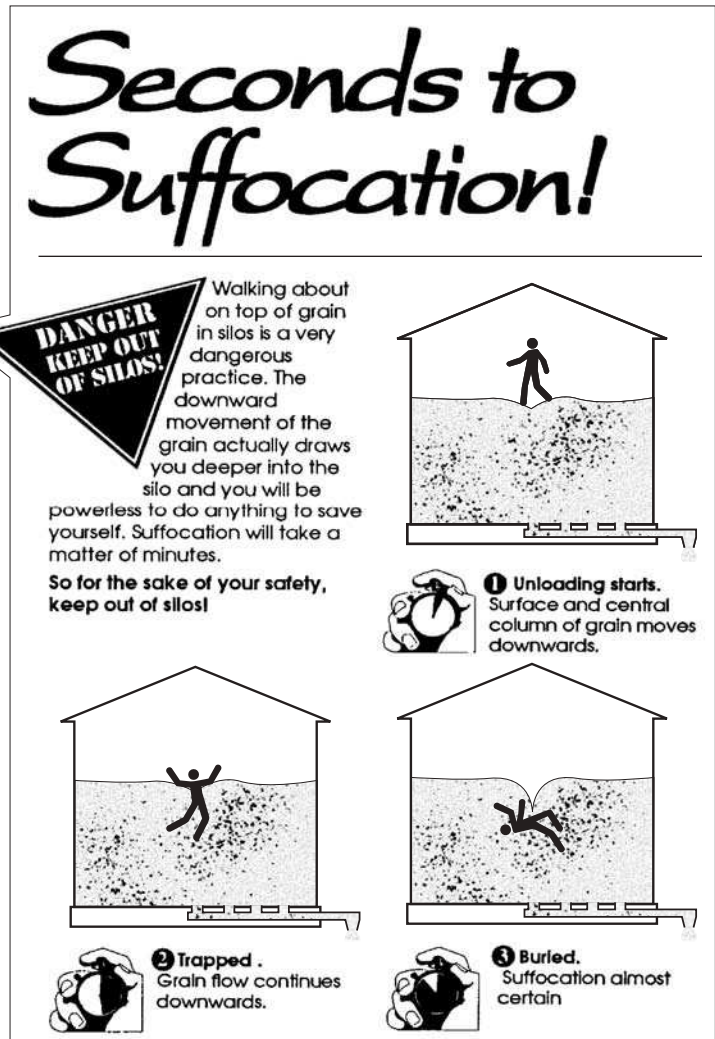

FIG. 2 SILO WARNING



FIG. 3 PLUGS

4.6 CONTROLS

Before starting to work, all operators should familiarize themselves with the location and function of controls.

1. Gas Engine:

Read the engine manufacturer's operator's manual before starting for more detailed instructions.

a. Ignition Switch:

This 3-position key-operated switch controls the electric power to the engine.

OFF

Turn key fully counter-clockwise to stop the electrical power and turn off the engine.

RUN

Turn clockwise on detent to the run position. This is the position where the engine will continue to operate.

START

Turn fully clockwise to the last spring-loaded detent position to engage the starter solenoid and start the engine. Release the key when the engine starts and it will return to the RUN position.

b. Choke:

This slide lever controls the position of the choke. Move the lever to the left to close the choke for starting when the engine is cold. Move the lever to the right to open the choke as the engine warms. Always move the lever fully to the right when operating the machine.

c. Throttle:

This slide lever controls the engine RPM. Move the lever to the left to increase engine speed and to the right to decrease.



FIG. 4 ENGINE

2. Electric Motor:

Each customer is responsible to provide the appropriate power supply to the machine. It is recommended that the customer have a licensed electrician provide power per ANSI/NFPA 70 Standard and all applicable local codes when providing power to the motor.

The Agri-Vac® can be wired into a large control room away from the machine or controlled by the control box supplied with the unit. If part of a control system, the customer must provide all the necessary components.

Be familiar with the typical control box before starting.

a. ON/OFF Switches:

This control box is provided by Walinga® and can be used to operate the machine. Push the top green button in to turn the machine ON. Push the bottom red button to turn the machine OFF.



FIG. 5 ON/OFF SWITCHES

4.7 FIELD OPERATION



OPERATING SAFETY

- Read and understand the Operator's Manual and all safety signs before operating, maintaining, adjusting or repairing the Agri-Vac®.
- Before servicing, adjusting, repairing or maintaining unit, ensure that unit power source is completely shut down and can not start up.
- Do not operate when any guards are damaged or removed, Install and secure guards before starting.
- Keep hands, feet, clothing and hair away from all moving and/or rotating parts.
- Clear the area of all bystanders, especially small children, before starting.
- Before supplying electrical power to the machine, be sure you have adequate amperage at the proper phase and voltage to run it. If you do not know or are unsure, consult a licensed electrician.
- Wear appropriate ear protection when operating machine.
- Do not place intake nozzle near feet when standing on the top of grain.
- Do not smoke while refueling.
- Do not place intake tube near feet when standing on top of material.
- Review safety instructions annually.

The Walinga® Agri-Vac® is used to pick up and move grain from one location to another on a stream of air. Before starting, the operator has the responsibility of being familiar with all operating and safety procedures and following them.

Each operator should review this section of the manual at the start of the season and as often as required to be familiar with the Agri-Vac®. When operating the machine, follow this procedure:

1. Clear the area of bystanders, especially small children before starting.
2. Review and follow the pre-operation checklist (See Section 4.4).
3. Move the machine to the working area and block the wheels to prevent movement.
4. Attach the intake and discharge hoses.
5. Attach the appropriate nozzle to the end of the intake hose.



FIG. 6 ELECTRIC MODEL INSTALLED

5. Starting:

A. Electric:

- a. Depress green ON button on control box.

B. Gas:

- a. Move choke lever into its OPEN position.
- b. Move the throttle lever midway between the "slow" and "fast" positions.
- c. Turn the ignition key clockwise to start the engine. Release key when engine starts.
- d. Slowly close the choke as the engine warms. Close choke completely when engine is warm and operating Agri-Vac®.
- e. Run for two minutes to fully warm engine before increasing to full RPM (Refer to engine owner's manual for complete start-up details).

6. Stopping:

A. Electric:

- a. Remove nozzle from grain and allow to empty.
- b. Depress red STOP button on control box.

B. Gas:

- a. Remove nozzle from grain and allow to empty.
- b. Slow engine to low idle RPM.
- c. Use ignition key to stop engine.

7. Emergency Stopping:

If an emergency occurs, the machine must be stopped immediately.

- a. Stop electric model by pressing red STOP button.
- b. Stop gas model by turning ignition key OFF.
- c. Correct emergency condition before resuming work.



FIG. 7 STARTING/STOPPING

8. Operating:

- a. Insert nozzle into grain with airslide completely open.
- b. Close airslide slowly until hose pulsates and then open slide an additional 1 ½ inches.
- c. Operate machine at this setting for ten minutes to warm system before putting under full load.
- d. After warm-up period, bring machine to full capacity.
- e. Close airslide until intake line starts to pulsate. Open slide slightly to stop pulsation.
- f. Watch glass window in receiver tank. Material should move past the window for the best performance.

9. Maximum Capacity:

- a. Place the nozzle into the grain with the inlet below the surface of the grain but not below the airslide. It is necessary that some air be allowed to enter through the airslide.
- b. Open the airslide completely to start. Close airslide until the hose starts to pulsate. Then open it until the pulsing stops. This will give a balanced grain and airflow condition.
- c. Watch for grain build-up on the window in the receiver tank. Grain must not lie stationary on the window. If grain builds up on the window, decrease the amount of grain entering the nozzle by opening the airslide.



FIG. 8 AIRSLIDE



FIG. 9 WINDOW

10. Specialty Crops:

When handling specialty products such as sunflower seeds, lentils etc, it is recommended that the blower speed be reduced. This gives a gentler action through the machine. Pulse crops are sensitive to cracking so a gentler action is required to minimize cracking. Electric models may need a different drive system installed. (Contact your dealer or the factory for details.)

11. Entering Bins:

- a. Open the vents to provide ventilation and to allow air to replace grain being removed.
- b. Do not enter bin if the grain is crusted or has built up a hard surface.
- c. Turn all other grain extraction equipment off and lock-out tag-out.
- d. Do not enter silo or bin until grain level is lowered to less than 12 inches (25 cm) above the floor or solid footing.
- e. Always have another person outside the facility to assist if the need arises.
- f. Go around the facility picking up all the remaining grain.

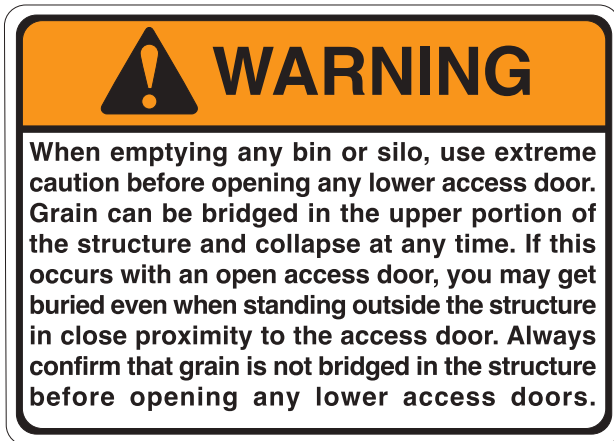

FIG. 10 GATHERING NOZZLE

12. Optional Equipment:

Several pieces of optional equipment are available to use with the Agri-Vac®. The list includes but is not limited to:

- a. Pre-Cleaner:
For removing abrasive material from the airflow to prevent it from going through the blower.

- b. Reducer:
To change size from 3 inch diameter to 2 inch diameter (or from 4 inch to 3"inch).

- c. Brush End:
Brush for cleaning up dust and loose grain.

- d. Wheeled Nozzle:
For cleaning grain on the surface.

- e. 3 inch hose
- f. 2 inch hose.
- g. Straight nozzle.
- h. Flared nozzle.



Pre-Cleaner



Reducer



Brush End



Wheeled Nozzle



Attachments

FIG. 12 OPTIONAL EQUIPMENT

i. Self-Dumping Hopper Bins.

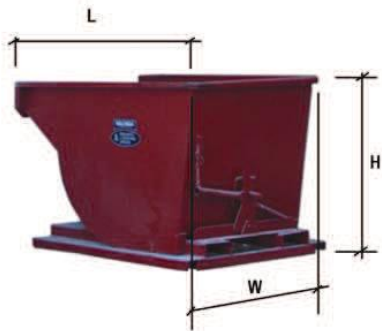

13. Silo Bags:

Do not enter silo bags. To prevent pulling the plastic into the nozzle, always slice the sides open and roll them back before starting.

14. Nozzle Use:

When on top of grain, do not push the nozzle into the pile next to the feet. The suction will pull the nozzle and the operator into the pile. If the pile is deep enough, the operator can be submerged under the grain and is suffocated.

15. Operating Hints:

- a. Try to keep the hoses as full as possible to have maximum capacity.
- b. Pull the intake nozzle out of the grain and empty the machine before shutting machine off.
- c. Route the lines to minimize bends and corners. If a corner is necessary, use a large radius elbow.
- d. Keep lines as short as possible to minimize friction losses.
- e. If long distance moving is required, push the grain rather than pull.
- f. If long distance moving is required, use solid metal tubing whenever and wherever possible.
- g. Always ground the air and grain lines to prevent static electrical build-up and sparking.
- h. Always push both clamps fully over-center to seal the junction and prevent leakage.

SELF-DUMPING HOPPER BINS

PART NO	DESCRIPTION				
	10 ga Steel Hopper, Self Dump C/W Safety Chains				
	Capacity (CY)	L (in)	W (in)	H (in)	Steel Lid (Optional) Part No
11-78297-6	.5	47	33	31	11-78281-6
11-64331-6	1	59	40	38	11-78280-6
11-78298-6	1.5	63	52	42	11-78282-6
11-78196-6	2	70	58	44	11-78197-6
11-70845-6	3	80	64	50	11-106955-6
11-78299-6	4	78	84	50	11-78296-6
11-78324-6	5	90	76	60	
11-78325-6	6	91	88	60	

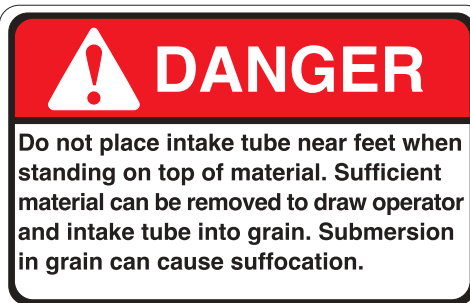

FIG. 11 JUNCTION (TYPICAL)

4.8 TRANSPORT



TRANSPORT SAFETY

- Comply with state and local laws governing safety and transporting of machinery on public roads.
- Disconnect grain and vacuum lines and plug before transporting.
- Do not drink and operate.

Walinga® Agri-Vacs® are designed to be easily and conveniently moved from location to location.

When transporting, follow this procedure:

1. Be sure all bystanders are clear of the machine.
2. Disconnect air and grain lines and stow.
3. Install and secure plugs in ports.
4. Use a forklift to lift machine onto a pick-up or truck and tie down securely.



FIG. 13 FORKLIFT POCKETS

4.9 STORAGE



STORAGE SAFETY

- Store away from areas of human activity.
- Do not allow children to play on or around the stored Agri-Vac®.
- Store unit in a dry, level area. Support the base with planks if required.

At the end of the season, the machine should be thoroughly inspected and prepared for storage. Repair or replace any worn or damaged components to prevent any unnecessary down time at the start of next season.

Follow this procedure:

1. Wash the entire machine thoroughly using a water hose or pressure washer to remove all dirt, mud, debris or residue.
2. Lubricate all grease points. Make sure all grease cavities have been filled with grease to remove any water residue from the washing.
3. Check the oil level in the blower reservoirs. Bring to the recommended level.
4. Install the plugs into the receiver tank inlet and air-lock outlet.
5. Touch up all paint nicks and scratches to prevent rusting.
6. All hoses should be stored inside or under a shelter.
7. Move the machine to its storage position.
8. Select an area that is dry, level and free of debris.
9. Motors should be stored in a clean, dry, ventilated location. When in storage the motor shaft should be turned several rotation every month and the bearings re-lubricated every year.
10. It is recommended that the starter be powered up once per year, for one hour continuously to avoid deterioration of electrolyte and subsequent starter failure.

4.10 CONVEYING OILSEEDS

For conveying oil seed commodities (such as sunflower seeds or canola) we recommend a raised tip blower and washout ports.

The raised tip blowers have a tip on the impellor that cleans the casing as the blower rotates.

After conveying oilseeds, we recommend washing the internal surfaces to remove any residue.

This will reduce the risk of seizing caused by a build up of oil residue.

5 SERVICE AND MAINTENANCE



MAINTENANCE SAFETY

- Follow ALL the operating, maintenance and safety information in the manual.
- Support the machine with blocks or safety stands when changing tires or working beneath it.
- Follow good shop practices:
 - Keep service area clean and dry.
 - Be sure electrical outlets and tools are properly grounded.
 - Use adequate light for the job at hand.
- Stop engine or motor, remove ignition key or lock-out tag-out electrical power and wait for all moving parts to stop before servicing, adjusting, repairing, unplugging or fitting.
- Use only tools, jacks and hoists of sufficient capacity for the job.
- Before servicing, adjusting, repairing or maintaining unit, ensure that unit power source is completely shut down and can not start up.
- Make sure all guards are in place and properly secured when maintenance work is completed.
- Keep hands, feet, hair and clothing away from all moving and/or rotating parts.
- Clear the area of bystanders, especially small children, when carrying out any maintenance and repairs or making any adjustments.

5.1 SERVICE

5.1.1 FLUIDS AND LUBRICANTS

1. Grease:
Use an SAE multi-purpose high temperature grease with extreme pressure (EP) performance rating meeting or exceeding the NLGI #2 rating for all requirements.
2. Blower Oil:
Use Walinga® Blower Oil part number 98-13813-5.

Model 3510	
Front	1 liter (1.1 qts)
Rear	1.35 liters (1.4 qts)

3. Storing Lubricants:
Your machine can operate at top efficiency only if clean lubricants are used. Use clean containers to handle all lubricants. Store them in an area protected from dust, moisture and other contaminants.

5.1.2 GREASING

Use the Maintenance Checklist provided to keep a record of all scheduled maintenance.

1. Use only a hand-held grease gun for all greasing. Air powered greasing systems can damage the seals on bearings and lead to early bearing failure.
2. Wipe grease fitting with a clean cloth before greasing to avoid injecting dirt and grit.
3. Replace and repair broken fittings immediately.
4. If a fitting will not take grease, remove and clean thoroughly. Also clean lubricant passageway. Replace fitting if necessary.

5.1.3 SERVICING INTERVALS

8 Hours or Daily

1. Use the sight glasses to check the oil level in the blower reservoirs (2 locations).

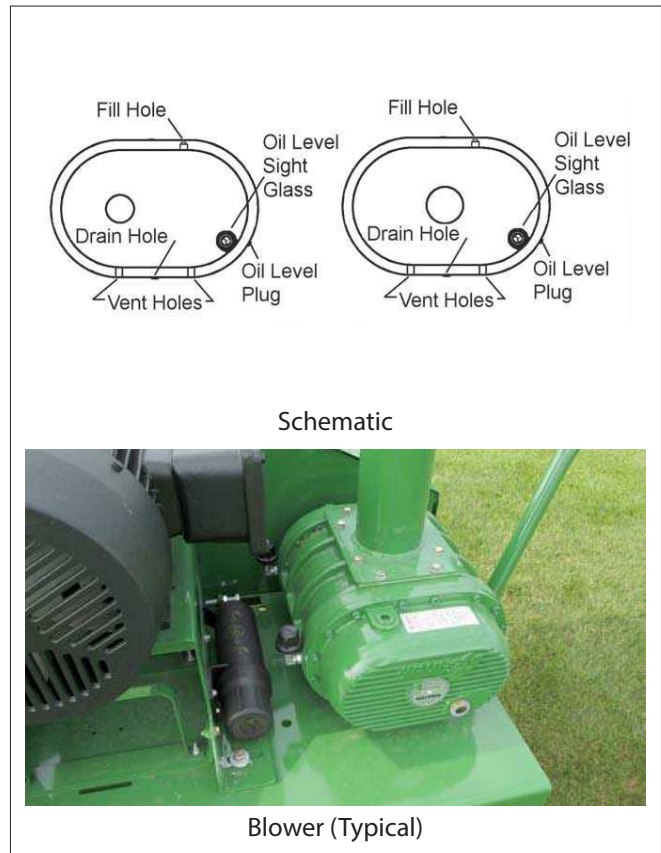

FIG. 14 RESERVOIRS

2. Check engine fluid levels (gas model only).
 - a. Fuel
 - b. Oil level



FIG. 15 GAS ENGINE

40 Hours or Weekly

1. Grease airlock drive jack shafts and bearings.

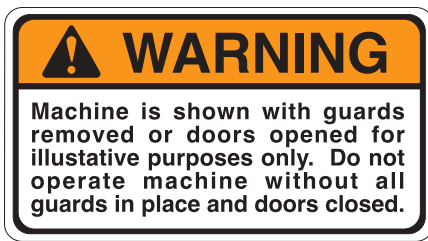

FIG. 16 JACK SHAFT BEARINGS

2. Check drive belt and chain tension.



Gas



Electric

FIG. 17 BELT AND CHAIN TENSION

3. Clean gas engine air filter.



FIG. 18 AIR FILTER

100 Hours or Annually

1. Change the oil in the blower oil reservoirs (2 locations) and clean head plate vent holes.

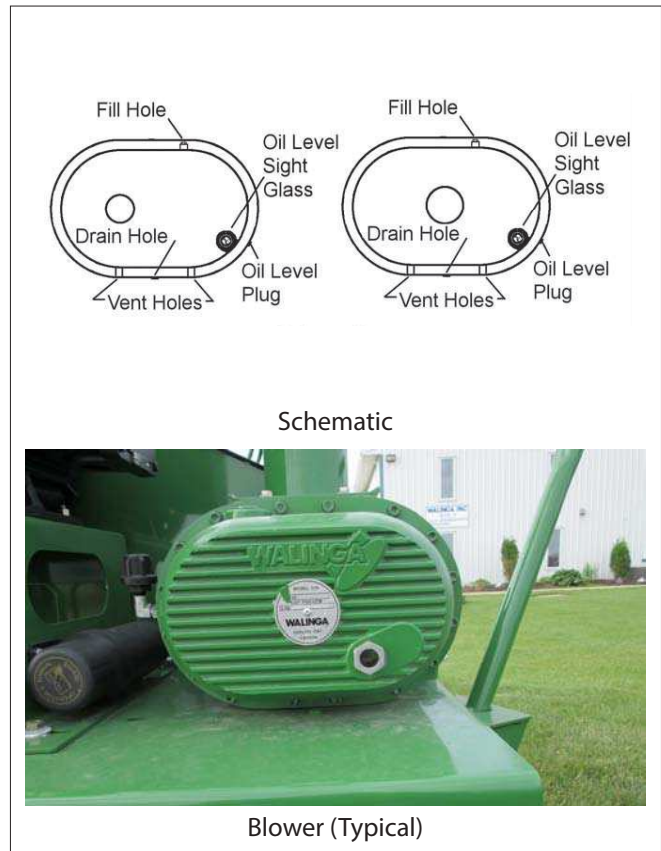

FIG. 19 BLOWER

2. Change engine oil - drain plug.
3. Change engine oil filter.



FIG. 20 ENGINE

4. Change inline fuel filter.



FIG. 21 INLINE FUEL FILTER

5. Grease steering wheel bushing.



FIG. 22 STEERING WHEEL BUSHING

5.1.4 SERVICE RECORD

See Lubrication and Maintenance sections for details of service. Copy this page to continue record.

ACTION CODE: CL CLEAN G GREASE CK CHECK
 CH CHANGE

MAINTENANCE													
HOURS													
SERVICED BY													
8 Hours or Daily													
CK Blower Oil Level (2 locations)													
CK Engine fluid levels (2 locations)													
40 Hours or Weekly													
G Airlock Drive Jack Shafts													
G Airlock Drive Bearings													
CK Drive Belt and Chain Tension													
CL Gas Engine Air Filter													
100 Hours or Annually													
CH Blower Oil													
CH Engine Oil													
CH Engine Oil Filter													
CH Inline Fuel Filter													
G Steering Wheel Bushing													

5.2 MAINTENANCE

By following a careful service and maintenance program on your machine, you will enjoy many years of trouble-free use.

5.2.1 CLEANING AIR CLEANER

1. Review the Operator's Manual for the engine.
2. Place all controls in neutral, stop engine, remove ignition key and wait for all moving parts to stop before maintaining.
3. Remove the cover over the air cleaner.
4. Remove the filter from the engine.
5. Use an air hose to blow the dust and debris out of the filter.
6. Install filter.
7. Install and secure the cover.



FIG. 23 AIR CLEANER

5.2.2 CHANGING ENGINE OIL AND FILTER

1. Review the Operator's Manual for the engine.
2. Place all controls in neutral, stop engine, remove ignition key and wait for all moving parts to stop before maintaining.
3. Allow the engine to cool before changing the oil. Hot oil can cause burns if it contacts exposed skin. It is best to change oil while the engine is warm to keep the contaminants in suspension.
4. Place a pan under the drain plug.
5. Remove the drain plug and allow the oil to drain for 10 minutes.
6. Install and tighten the drain plug.
7. Dispose of the used oil in an approved container.
8. Remove engine oil filter.
9. Apply a light coat of oil to the O-ring and install the replacement filter. Snug up by hand and then tighten $\frac{1}{2}$ turn.
10. Fill the crankcase with the specified oil.
11. Run the engine for 1-2 minutes and check for oil leaks.
12. If leaks are found around the drain plug tighten slightly. Repeat step 9.
13. Check engine oil level. Top up as required.

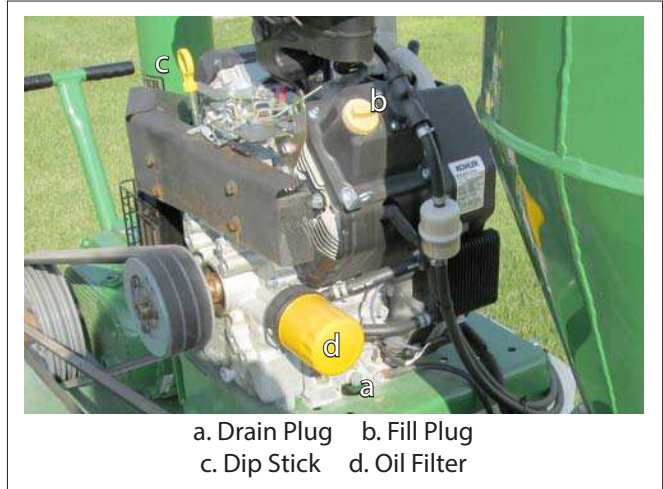

FIG. 24 ENGINE OIL AND OIL FILTER



5.2.3 CHANGING INLINE FUEL FILTER

The gas model Agri-Vac® is designed with an inline fuel filter to insure clean fuel goes to the engine. Change the inline fuel filter annually or more often if its gets dirty. To change the filter, follow this procedure:

1. Place all controls in neutral, stop engine, remove ignition key and wait for all moving parts to stop before maintaining..
2. Apply clamps to fuel line on each side of the fuel filter.
3. Remove fuel filter and wipe up any spilled fuel.
4. Install replacement fuel filter.
5. Remove clamps on fuel lines.
6. Clean up any spilled fuel.



FIG. 25 INLINE FUEL FILTER

5.2.4 BELT TENSION AND ALIGNMENT

Rotational power from the power source is transmitted to the blower and airlock through the belt drive (electric model). To obtain efficient transmission of power and good belt life, the belts must be properly tensioned and the pulleys aligned.

Belts that are too tight will stretch and wear quickly or overload the bearings. Belts that are too loose will not transmit the required power and will slip, overheat and wear quickly. Pulleys that are not aligned will result in rapid belt wear.

Follow this procedure when checking and adjusting belt tension and pulley alignment.

1. Clear the area of all bystanders, especially small children.
2. Stop the unit wait for all moving parts to stop before maintaining.
3. Ensure that the unit power source is completely shut down and can not start up. Lock-out tag-out power source.
4. Unbolt and remove the belt/chain cover. Lay to the side.
5. Use a 7 pound weight to determine the belt deflection in a static condition on a new Agri-Vac[®].

There should be a ¼ inch deflection.

6. Adjusting Tension:
 - a. Loosen the jam nuts on the adjusting bolts. Loosen hold-down bolts slightly.
 - b. Turn the adjusting bolt to set the tension. Maintain pulley alignment.
 - c. Check the tension again. Overtightening will cause belt stretching and overload the bearing. Belts that are too loose will slip, tear and wear rapidly. Check alignment (next page).
 - d. Tighten jam nuts. Tighten hold-down bolts.
 - e. Install and secure guards/covers.

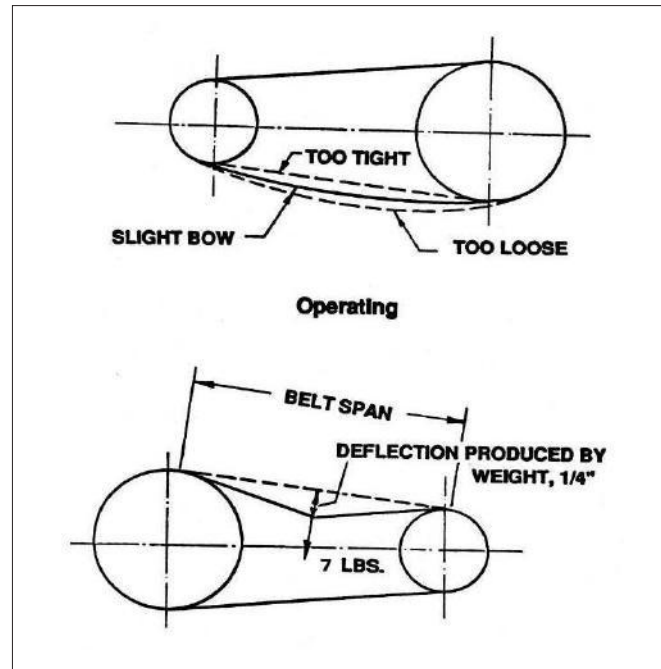

FIG. 26 BELT DEFLECTION MODEL 3510

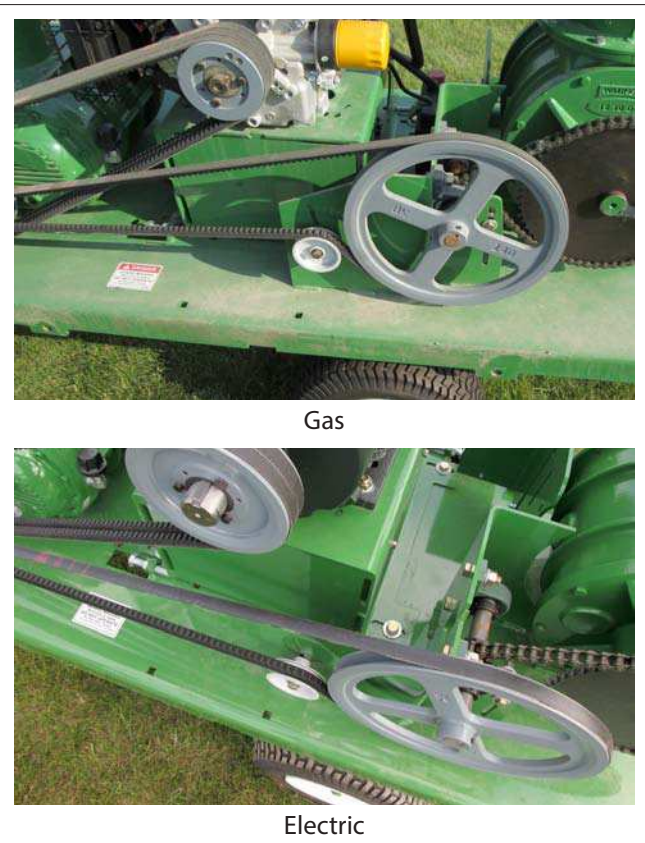
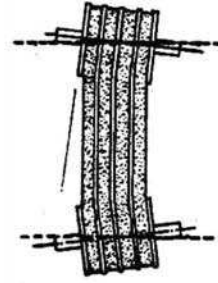

FIG. 27 ADJUSTING BOLTS

7. Pulley Alignment:

- a. Lay a straight-edge across the faces of the two pulleys.
- b. If the gap between the pulley and the straight-edge exceeds 1/16 inch (1.5mm), the pulleys must be realigned.
- c. Measure the distance the pulley needs to move.
- d. Loosen belts.
- e. Remove bolts from the pulley which is to be moved.
- f. Install bolts into pulleys' threaded holes and force pulley from bushing. Use all bolts with equal force to ensure that bushing is not damaged.
- g. Move bushing as per measurement required.
- h. Re-install sheave onto bushing.
- i. Re-install belts.

1. Shafts are not parallel to one another.



2. Shafts are not in correct alignment although they appear parallel when seen from above.

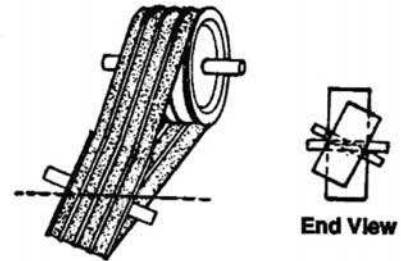

3. Shafts are parallel and in alignment but pulleys are not in alignment.

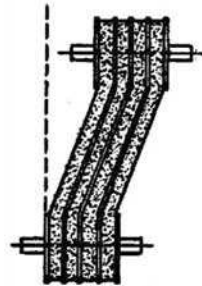

4. Correct installation both shafts and pulleys are parallel and in alignment.



FIG. 28 BELT ALIGNMENT

8. Power Unit Base Adjustment:
If the moving of pulleys does not align them, the base of the engine or motor can be adjusted for alignment. To move engine or motor follow this procedure:
- a. Determine the type of pulley mis-alignment.
 - b. Loosen belts.
 - c. Loosen power unit base anchor bolts.
 - d. Loosen position bolt jam nuts.
 - e. Use position bolts to move power unit base (on each corner of base).
 - f. Check pulley alignment. Move base again as required.
 - g. Tighten position bolts and jam nuts to their specified torque.
 - h. Tighten base anchor bolts.
 - i. Tighten belts.
 - j. Install and secure guard.

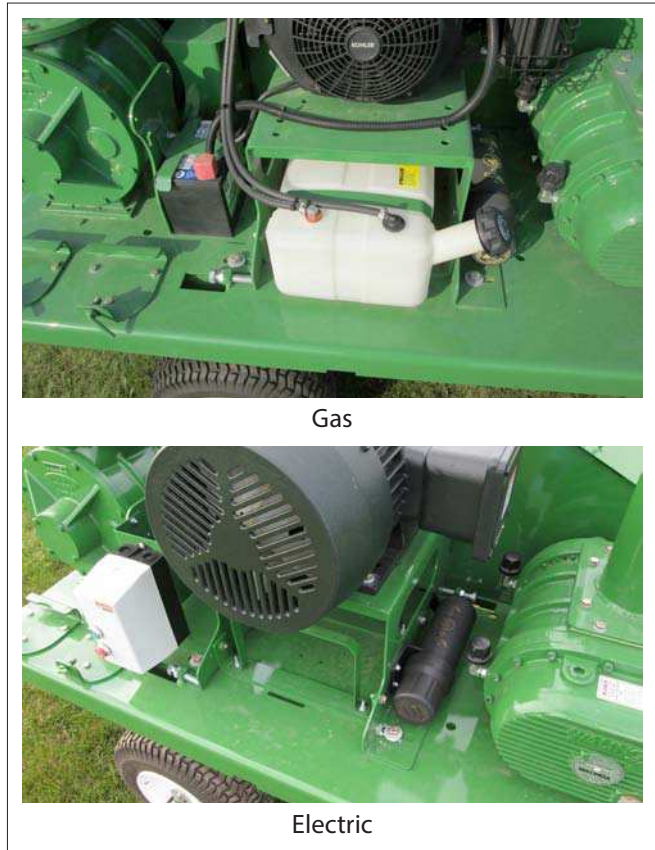

FIG. 29 ENGINE/MOTOR BASE

5.2.5 CHAIN TENSION

Rotational power from the jack shaft is transmitted to the airlock through the chain drive. To obtain efficient transmission of power and good chain life, the chain must be properly tensioned.

Chains that are too tight will stretch and wear quickly or overload the bearings. Chains that are too loose will skip on the sprocket and cause sprocket damage.

Follow this procedure when checking and adjusting chain tension:

1. Clear the area of all bystanders, especially small children.
2. Stop the unit and wait for all moving parts to stop before maintaining.
3. Ensure that the unit power source is completely shut down and can not start up. Lock-out tag-out.
4. Unbolt and remove the belt/chain cover. Lay to the side.
5. Loosen block tensioner bolt.
6. Press the block tensioner against chain.
7. Retighten block tensioner bolt.
8. Install and latch belt/chain cover.
9. Be sure all guards are installed and secured before resuming work.

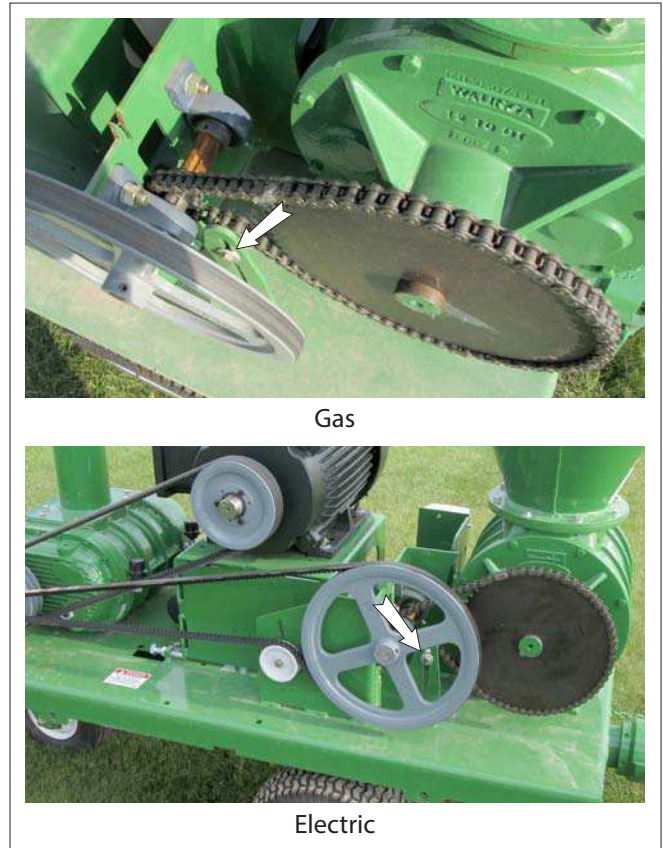
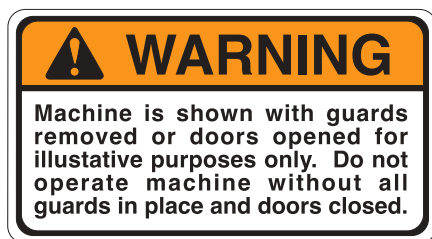

FIG. 30 CHAIN TENSION

5.2.6 BLOWER OIL CHANGING AND BREATHER CLEANING

The gears that drive and time the blower lobes run in an oil bath for lubrication. Maintaining the correct level in the reservoirs and changing every 100 hours will insure proper lubrication.

When maintaining the blower, follow this procedure:

1. Clear the area of bystanders, especially small children.
2. Before servicing, adjusting, repairing or maintaining unit, ensure that unit power source is completely shut down and can not start up. Lock-out tag-out power source.
3. Remove anchor bolts and remove the belt drive covers.
4. Checking Oil Level:
 - a. Remove the level plug in each reservoir or check the sight glass.
 - b. Oil in the reservoir should just fill the threads of the level plug hole.
 - c. Add oil if low or allow the reservoir to drain if over-filled (Use Walinga® Super Duty Blower Oil Part # 98-13813-5).
 - d. Install and tighten the level plug.
 - e. Install and secure the belt/chain covers.

IMPORTANT:

It is necessary to maintain the recommended oil level in the reservoir. A low level causes heating from lack of lubrication and rapid gear and bearing wear. Too much oil causes heating from oil churning and can cause seal and breather leaks.

IMPORTANT:

Check the level only when the oil is cold and the machine is level.

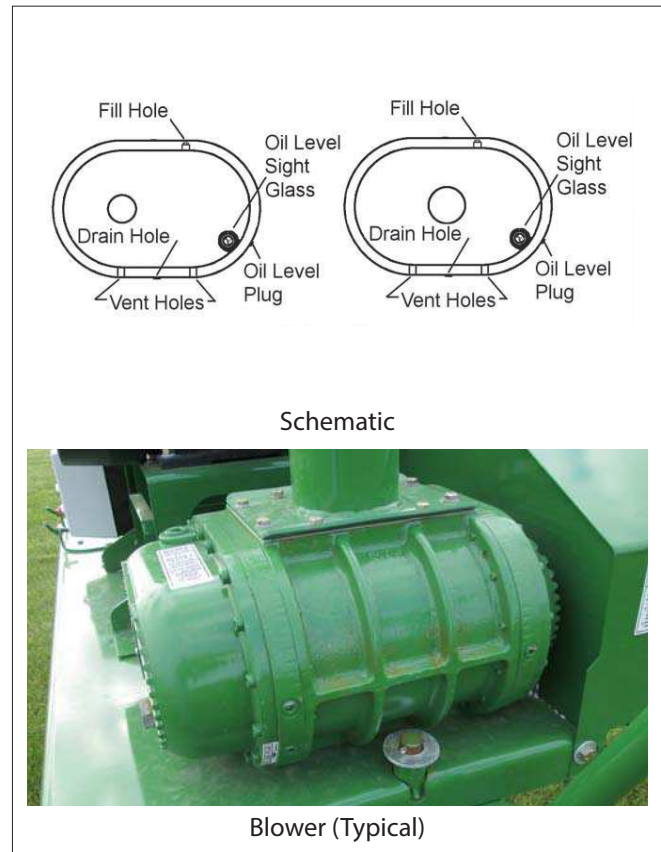

FIG. 31 BLOWER

5. Changing Oil:

- a. Place a collection pan or pail under each drain plug.
- b. Remove each drain plug.
- c. Flush each case and allow several minutes to drain.
- d. Dispose of the oil in an approved manner. Do not contaminate the worksite with used oil.
- e. Install and tighten the drain plugs.
- f. Remove fill and level plug.
- g. Add Walinga® Blower oil or equivalent to each reservoir until the oil is just starting to come out of the level plug hole or half way in sight glass.

IMPORTANT

Condensation forms and collects inside the reservoirs during machine operation. Changing oil removes this water and prevents it from damaging the gears and bearings.

- h. Install and tighten the level and fill plugs.
- i. Install and secure the belt/chain drive covers.

6. Cleaning Breathers:

- a. Remove breathers and blow out with an air hose.
- b. If dirt has caked up in the breather, soak in good solvent and then blow out. It may be necessary to use a probe to loosen the dirt.
- c. Install and tighten the breather.
- e. Install and secure the belt drive covers.
- f. Clean vents in end plates located under the blower on either side of the drain plug.

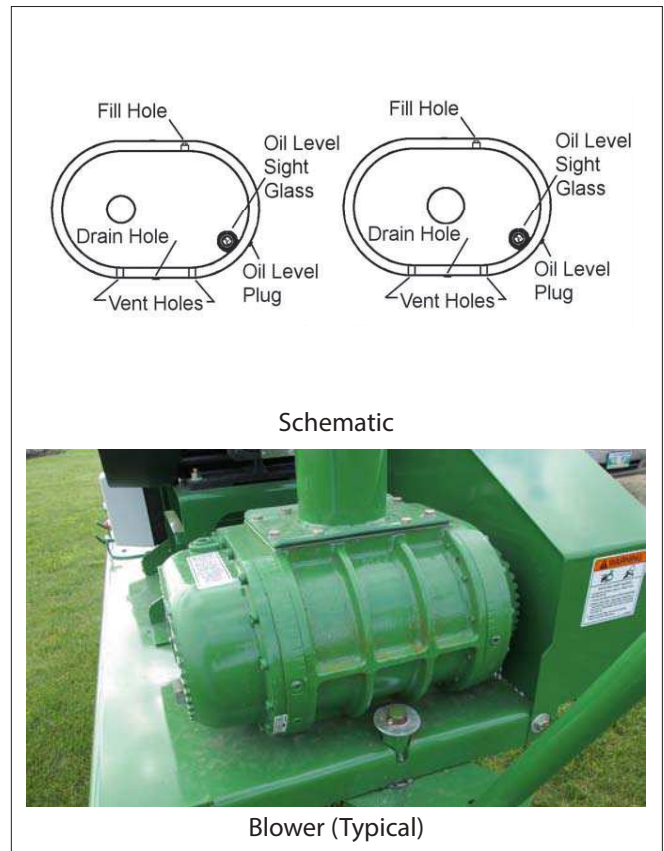

FIG. 32 BLOWER

5.2.7 AIRLOCK

The airlock acts as a seal between the vacuum and pressure sides of the machine and is located at the bottom of the receiver tank. As the rotor turns, a pocket is filled with material when it points upward. As the pocket rotates, it is moved to the bottom and is moved into the pressure side of the system. The grain is picked up by the stream of pressurized air and moved out the discharge piping.

Efficient operation of the airlock requires a pressurized fit between the tips of the rotor and the case to maintain a seal between vacuum and pressure sides.

When checking or maintaining the airlock, follow this procedure:

1. Clear the area of bystanders, especially small children.
2. Checking Tip Clearance:
 - a. Checking the airlock can be done through the inspection door at the top of the tank.
 - Remove tank access lid assembly. Remove belt cover.
 - Rotate drive system by hand and watch tips rotate in airlock .Tips need to contact the casing of the airlock and bend back slightly as they pass from open area to the airlock housing.
 - b. This contact of the tips must be maintained at all times. Adjust or replace tips as required to insure system sealing.
 - c. Replace any tips that are chipped or broken.

NOTE:

Tips are reversible if not excessively damaged.



Airlock

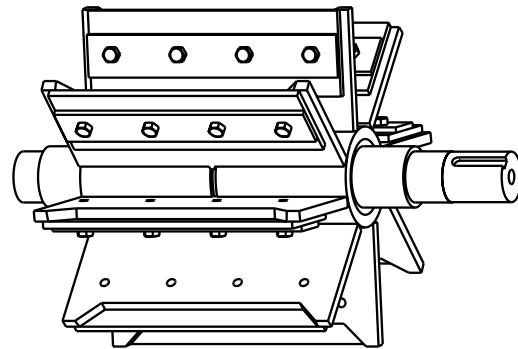

Drawing

FIG. 33 MACHINE

3. Tip Adjustment:

- a. Ensure that the unit power source cannot start up. Lock-out tag-out power source.
- b. Lift the receiver tank off the airlock.
- c. Loosen tip from rotor.
- d. Raise tip up and tighten bolts.
- e. Rotate the airlock and watch to make sure tip bends back slightly as it rotates into housing.
- f. Repeat procedure with other tips.
- g. Install tank top.
- h. Install belt/chain cover.

6. Tip Replacement:

- a. Ensure the unit power source can not start up.
- b. Lift the receiver tank off the airlock.
- c. Remove the tips from the rotor.
- d. Mount the tips to their respective vane and tighten bolts finger tight.
- e. Rotate the airlock and watch to make sure tip bends back slightly as it rotates into housing.
- f. Repeat procedure with other tips.
- g. Tighten all fasteners to their specified torque.
- h. Install tank top.
- i. Install belt/chain cover.

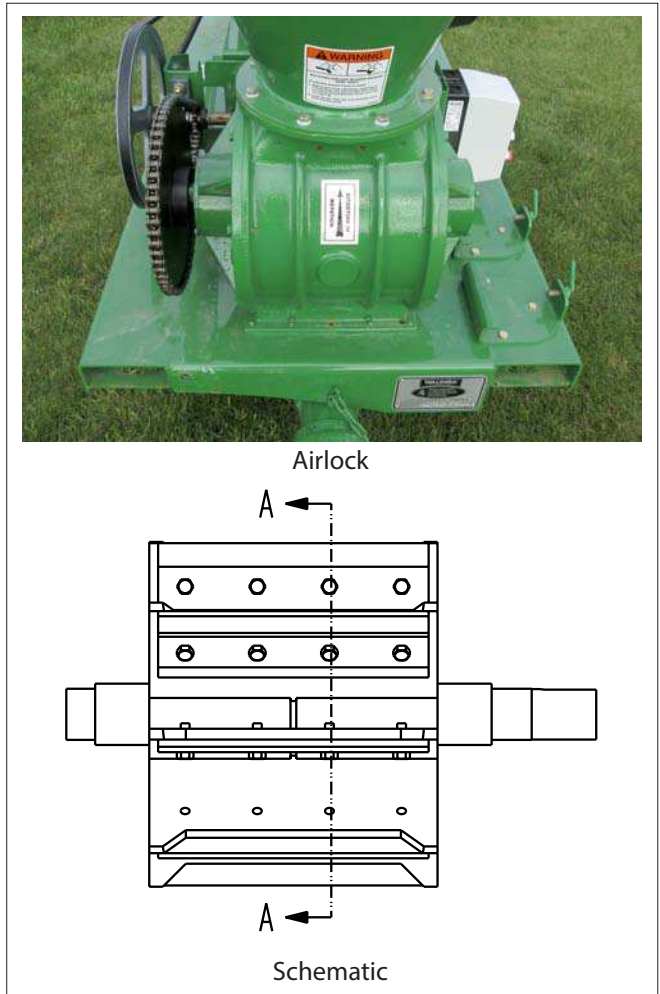

FIG. 34 TIP ADJUSTMENT

6 TROUBLE SHOOTING

The Walinga® Agri-Vac® is a high capacity air pump that creates a vacuum for picking up grain and supplies pressurized air for moving the grain. It is a simple and reliable system that requires minimum maintenance.

In the following section, we have listed many of the problems, causes and solutions to the problems that you may encounter.

If you encounter a problem that is difficult to solve, even after having read through this trouble shooting section, please call your Walinga® dealer. Before you call, please have this Operator's Manual and the serial number from your Agri-Vac® ready.

6.1 MOBILE TRANSFER UNIT

PROBLEM	CAUSE	SOLUTION
Slow to pick up grain.	Receiver choke activated.	Shut down and restrt.
	Air leaks.	Tighten all vacuum connections. Be sure seals are in good condition.
		Check hoses for leaks.
		Check hose coupling gaskets.
		Tighten receiver coupling to base.
		Check seal on pre-cleaner bottom door (if so equipped). Close and secure.
		Check blower belt tension.
	Improper setting of airslide.	Reset airslide.
	Defective airlock.	Check airlock tip clearance (see 5.2.7). Adjust or replace tips as required.
Defective blower.	Check clearance between lobes and case. Excessive clearance will decrease airflow. Consult your dealer.	
Airslide open too far.	Slowly close airslide in increments.	
Slow discharge of grain.	Air leaks.	Tighten all pressure connections. Be sure seals are in good condition. Check hose coupling gaskets. Check hoses for leaks. Check airlock belt tension.
	Defective blower.	Check clearance. Excessive clearance will decrease airflow (see 5.2.6). Consult your dealer.
	Defective airlock.	Check that tip tension is correct. Adjust or replace tips as required (see 5.2.7).
Pulsation.	Not enough airflow.	Open airslide nozzle to provide more air. Increase blower speed or decrease size of intake piping.
	Too many bends.	Straighten out intake lines.

PROBLEM	CAUSE	SOLUTION
Blower overheating.	Not enough airflow.	Open air slide nozzle to provide more air.
	Plugged screen.	Clean screen.
	Low oil level.	Add oil as required.
Product damage.	Poor connections.	Tighten and seal all connections.
	Lines wearing.	Eliminate elbows. Keep lines as straight as possible and provide a large radius for bends.
	Excessive RPM speed.	Decrease airflow by slowing blower or increasing size of lines.
Increase grain quantity by closing airslide.		
Blower bogging down.	Blower oil lacking.	Change oil - contact dealer.
	Belts slipping.	Tighten belts.
	Power source slowing.	Check power source.

6.2 AIRLOCK

PROBLEM	CAUSE	SOLUTION	
Noisy airlock.	Rotor hitting case.	Replace bearings.	
Airlock stalls.	Airlock jammed.	Reverse airlock direction to clear.	
		Remove receiver tank lid or remove entire receiver tank. Remove obstruction from airlock.	
			
		Tips too tight.	Loosen bolts. Refer to airlock maintenance.
		Faulty airlock rotor.	Rotor damaged. Repair or replace airlock.
Faulty airlock drive.	Repair or replace drive.		
Air loss through airlock.	Tip clearance too large.	Adjust tips (see 5.2.7).	

6.3 BLOWER

PROBLEM	CAUSE	SOLUTION
Low air volume.	Slow speed.	Check for slipping belts. Adjust belt tension as required.
	Piping blocked.	Check inlet and outlet piping. Remove obstruction.
	Excessive pressure rise.	Check inlet vacuum and discharge pressure and compare with recommended conditions. Determine cause before continuing.
	Worn components.	Check clearance and replace defective components. Refer to blower manual.
Over heating.	Inadequate lubrication.	Check oil level in reservoirs. Add as required.
	Excessive lubrication.	Check oil level. Correct as required.
	Excessive pressure rise.	Adjust operating conditions to reduce pressure rise to below 6 psi.
	Coupling mis-alignment.	Check and realign.
Power source overloading.	Speed too high.	Check and decrease speed to recommended RPM.
	Pressure too high.	Adjust operating conditions to reduce pressure rise to below 6 psi.
	Impellers rubbing.	Consult your nearest dealer.

6.4 V-BELT DRIVE

PROBLEM	CAUSE	SOLUTION
Loss in drive speed.	Belts slipping.	Tighten belts as required.
	Localized belt wear.	Check belt cross-section dimension. a. If narrow, pulley spinning. b. If swollen, belt failing internally.
	Unequal stretch on belts.	Defective belts. Replace with matched set.
	Belts overloaded.	Belts failed or worn out. Replace belts with matched set.
	Belt separation.	Belts too tight. Replace belts and set correctly.
	Envelope seams opening.	Check for oil or rubber solvent. Eliminate contamination and replace belts.
	Abnormal envelope wear.	Check for worn sheave, misalignment or slip. Replace defective parts, adjust properly and replace belt.
	Belt softening or swelling.	Eliminate oil or rubber solvent. Replace belt.
	Belt hardening or cracking.	Eliminate heat or chemical contamination. Replace belt.

7 SPECIFICATIONS

7.1 MECHANICAL

7.1.1 Mechanical Specifications:

	3510 GAS	3510 E
LENGTH	78 inch (198 cm)	78 inch (198 cm)
WIDTH	34" inch (86 cm)	34" inch (86 cm)
HEIGHT	73 inch (185 cm)	73 inch (185 cm)
WEIGHT	1373 lbs. (623 kg)	1373 lbs. (623 kg)
WHEELS	3 pneumatic (1 on swivel)	3 pneumatic (1 on swivel)
BLOWER	#510 Walinga blower	#510 Walinga blower
AIRLOCK	# 1210 drop-thru cast iron	# 1210 drop-thru cast iron
FRAME	1 piece formed steel	1 piece formed steel
MOTOR // POWER	27 hp gas (20.2 kw)	10, 15, or 20 hp (7.5, 11, 15 kw)
STARTER	12 volt	ATL
RECEIVER	18" dia.x 36" high (46 x 91cm)	18" dia.x 36" high (46 x 91cm)
INLET	4" (100mm) daffin coupling with plug	4" (100mm) daffin coupling with plug
OUTLET	4" (100mm) daffin coupling with plug	4" (100mm) daffin coupling with plug

Due to continuous product development, specifications are subject to change without notice.

7.1.2 Capacities:

PRODUCT MODEL	Barley		Corn		Wheat		Beans	
	Bu/hr	Tonnes per hr	Bu/hr	Tonnes per hr	Bu/hr	Tonnes per hr	Bu/hr	Tonnes per hr
3510 30hp GAS	900	23	700	18	575	15	500	13
3510 E (20hp)	700	18	650	17	500	13	450	12
3510 E (15hp)	550	14	500	13	375	10	350	9
3510 E (10hp)	400	10	350	9	250	7	225	6

* Capacities based on using 12' (3.65 m) suction line and 12' discharge line. Capacity will vary with condition of product.

SPECIFICATIONS SUBJECT TO CHANGE WITHOUT NOTICE

7.2 BOLT TORQUE

CHECKING BOLT TORQUE

The tables shown below give correct torque values for various bolts and capscrews. Tighten all bolts to the torques specified in chart unless otherwise noted. Check tightness of bolts periodically, using bolt torque chart as a guide. Replace hardware with the same strength bolt.

ENGLISH TORQUE SPECIFICATIONS

Bolt Diameter "A"	SAE 2		Bolt Torque*		SAE 8	
	(N.m.)	(lb-ft)	(N.m.)	(lb-ft)	(N.m.)	(lb-ft)
1/4"	8	6	12	9	17	12
5/16"	13	10	25	19	36	27
3/8"	27	20	45	33	63	45
7/16"	41	30	72	53	100	75
1/2"	61	45	110	80	155	115
9/16"	95	60	155	115	220	165
5/8"	128	95	215	160	305	220
3/4"	225	165	390	290	540	400
7/8"	230	170	570	420	880	650
1"	345	225	850	630	1320	970

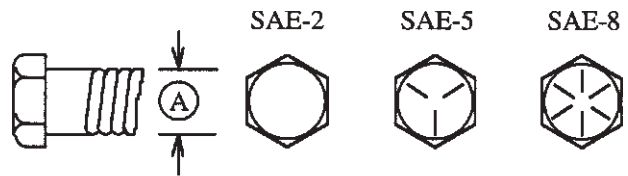

METRIC TORQUE SPECIFICATIONS

Bolt Diameter "A"	Bolt Torque			
	8.8		10.9	
	(N.m.)	(lb-ft)	(N.m.)	(lb-ft)
M3	.5	.4	1.8	1.3
M4	3	2.2	4.5	3.3
M5	6	4	9	7
M6	10	7	15	11
M8	25	18	35	26
M10	50	37	70	52
M12	90	66	125	92
M14	140	103	200	148
M16	225	166	310	229
M20	435	321	610	450
M24	750	553	1050	774
M30	1495	1103	2100	1550
M36	2600	1917	3675	2710

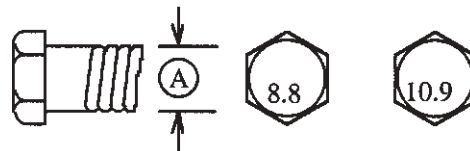

Torque figures indicated above are valid for non-greased or non-oiled threads and heads unless otherwise specified. Therefore, do not grease or oil bolts or capscrews unless otherwise specified in this manual. When using locking elements, increase torque values by 5%.

* Torque value for bolts and capscrews are identified by their head markings.

LIST OF ITEMS

ITEM NUMBER	DESCRIPTION
1	HOLDER FOR DM4
2	HANDGRIP, 1.0" ID x 4.37
3	SHEAVE, 9.4 x 3-B x SK
4	BUSHING, SK x 2" x 1/2" KW
5	SHEAVE, 4.6 X 3-B X SD
6	Bushing, SD x 1-1/8" x 1/4" KW
7	Sheave, 1-BK-140-1
8	PULLEY, BLOWER SHAFT, 3510G/E, BK19
9	WHEEL, 16.3 OD x 6.7 WIDE
10	DOCUMENT HOLDER - PLASTIC
11	V-Belt, BX100
12	SWIVEL WHEEL ASSY, 3510
13	RCVR ASSY, 3510, W/FLIGHTING
14	RCVR TOP, 3510, BOLT ON
15	V-Belt, BX70
16	FLAT BELT TENSIONER
17	FRAME ASSY,3510,CHAN,2015
18	BELT COVER,3510,2015
19	SHAFT, 1 DIA X 1/4 KW, 7-1/2LG
20	SLIDE RAIL 7 1/2-30 HP,3510,2015
21	BLOWER INLET ASSY,3510,2015
22	1" PLASTIC ROLLER
23	T-BOLT CLAMP, 5-1/2",C410C-75-550-S
24	PLASTIC KNOB; T-BOLT CLAMP
25	WHEEL 13/500-6 4PLY W/PARTS
26	A/L,1210DT FXR,V-ROTOR,FLEX TIP
27	DP-4 PLUG WITH CHAIN
28	BLOWER,510,CHR,3.25"
29	ELB,5x90D,DBL BEND 5.5 CLR,14GA,CS
30	PIPE, STL, SCH-40, 3/4" DIA - 1-1/4 LG
31	PIPE, STL, SCH-40, 1" DIA - 1-1/2 LG
32	CONNECTION HOSE 5" DIA - 6 LG
33	FLAT,CRS,1/4x1/4 - 1-1/8 LG
34	PLATE WASHER, 3/4", PLTD, A-N
35	MB 3/8-16-4 GR8 HH PLTD
36	NUT LOCK HEX 3/4-10 Gr 8 PLTD
37	MB 3/4-10-7 1/2 GR8 HH PLTD
38	510 BLOWER GASKET
39	BEARING, UCP 205-100D1
40	SPROCKET, 50B80, 1-1/4" BORE, 5/16" KW
41	SPROCKET, 50B10, 1" BORE, 1/4" KW
42	CHAIN, 50WP,0-115IN - 44-3/8 IN

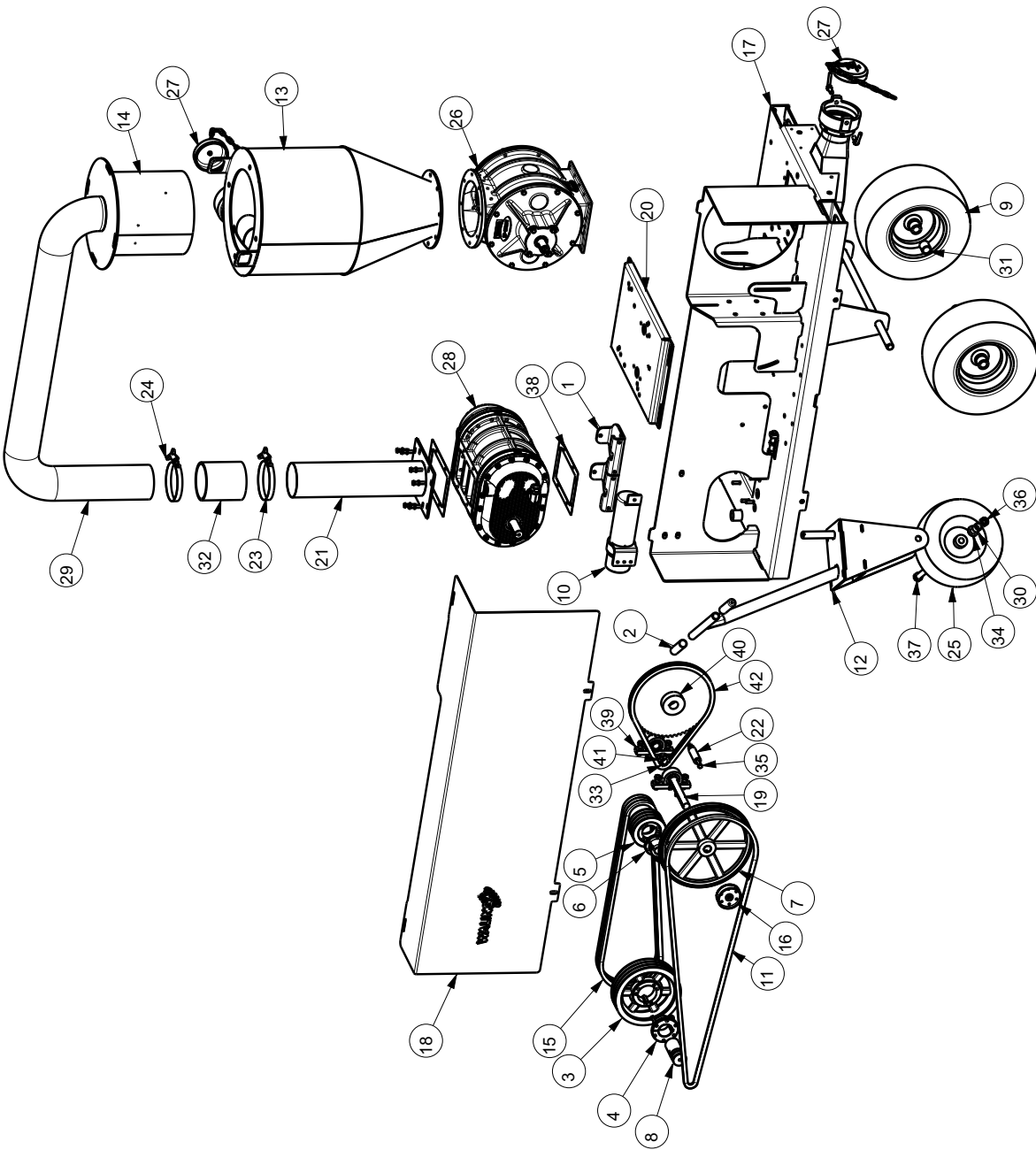

THIS DOCUMENT CONTAINS
 PROPRIETARY INFORMATION
 WHICH IS UNLAWFULLY
 REPRODUCED OR IN PART
 DISCLOSED IN WHOLE OR IN PART
 WITHOUT THE PRIOR WRITTEN
 CONSENT OF WALINGA INC.

WALINGA
 ENGINEERED
 FOR
 EQUIPMENT

DOCUMENT TITLE: **SALES/SERVICE,3510,2015,NO DRIVE**

DRAWN BY: RZV DOCUMENT NUMBER: **00-102213-0**

DRAWN DATE: 02-APR-15 REVISION: SHEET NUMBER: **1 of 1**



3510
Operator's Manual

WALINGA®

CORPORATE HEAD OFFICE:

5656 Highway 6N
RR#5, Guelph, Ontario, N1H 6J2
PHONE: (888) 925-4642 FAX: (519) 824-5651
www.walinga.com

AGRI-VAC MANUFACTURING FACILITY:

938 Glengarry Cres., Fergus, Ontario Canada N1M 2W7
Tel: (519) 787-8227 Fax: (519) 787-8210

DISTRIBUTION AND SERVICE CENTRES:

5656 Highway 6N, Guelph, Ontario Canada, N1H 6J2
Tel: (888) 925-4642 FAX: (519) 824-5651

1190 Electric Ave. Wayland, MI, USA 49348
Tel: (800) 466-1197 Fax: (616) 877-3474

70 3rd Ave. N.E. Box 1790 Carman, Manitoba Canada R0G 0J0
Tel: (204) 745-2951 Fax: (204) 745-6309

24 Molloy Street, Toowoomba, Queensland Australia 4350
Tel: 07-4634-7344 mail@customvac.com.au

PRINTED IN CANADA

ISSUE DATE: OCTOBER 2014

OM PART #34-18319-6 v2.5 01082019