

Grain Cleaner



Grain Cleaner WALINGA INC.

MAXIMIZE GRAIN HANDLING PROFIT!

Growing with our customers, the Walinga Grain-Cleaner is the newest addition the Walinga family of grain handling equipment. Together with our clients we have combined their best field practices with Walinga engineering to produce the ideal solution for removing dust, 'bees-wings' and fines from your grain before storage and transporting to sale point. Walinga equipment is, as always, designed with foremost consideration for the operator.

The Grain-Cleaner is a totally enclosed system that not only cleans the grain but prevents the release of smaller particulate matter back into the air we breathe.

Heavy duty bristles and 10" discharge augers ensure perfectly cleaned grain delivered at an exceptional rate of speed.

Available as Self-Contained Units and Dryer Mounted Units, with different screen sizes available, the Walinga Grain-Cleaner is another example of a quality Walinga product developed to meet the needs of our customers.

10" Intake Dryer Mount

The ten inch auger intake with single fan dryer mount unit has been a mainstay design since being first introduced. Both the dryer mounted and self contained ten inch cleaners move up to 1,100 bu/hr*. Removing fines and beeswings from grains helps eliminate storage hotspots.



FEATURES AND BENEFITS

- 2', 4' and 6' Extensions Available
- Heavy Duty Construction
- 10" Heavy Duty Steel Auger
- Electric Twin Belt Drive
- Quick & Easy Access Lid
- 3HP Fan/Blower
- Heavy Duty Bristles

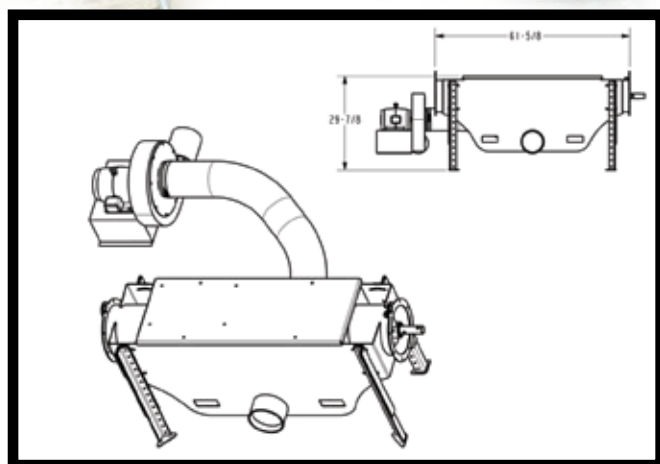

DRYER MOUNTED UNIT

DIFFERENT SCREEN STYLES AVAILABLE

Available in both 10" and 16" formats, choose from a wide selection of screen styles to best clean corn, soybeans, wheat, edible beans, barley, durum, flax, etc.

BRUSH AUGER FLIGHTING [Cutaway]

Auger flighting sections within screens are edged with durable heavy duty nylon bristles to help facilitate the loosening of beeswings and debris.



10" Intake, Self Contained

The ten inch auger, single fan unit is also available in a popular stand-alone unit. Collected fines and beeswings, not only increase the value of stored grains, the collected debris can be returned to the fields as valuable nutrient rich cover during seeding.

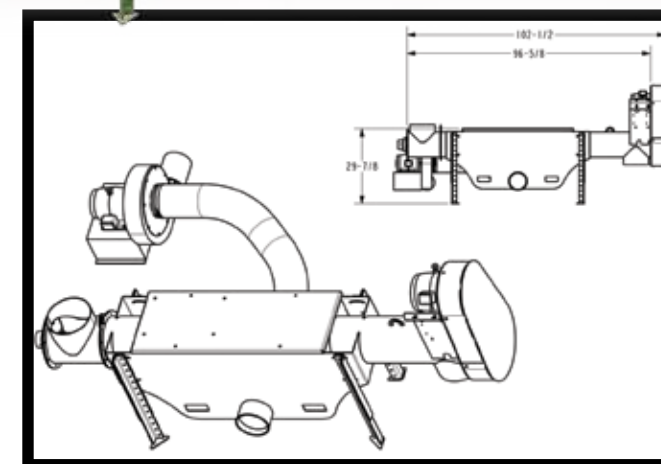

SELF CONTAINED UNIT

DID YOU KNOW?

Walinga's skilled engineers are here to help. Engage with Walinga to assist in designing your optimal grain cleaner solution. Whether you want to build to scale or plan for a larger future, Walinga's team will help you plan and complete the installation you desire.

16" GRAIN CLEANER

Maximized Performance



16" Intake, Dual Fans

Walinga's most powerful self contained grain cleaner. A larger sixteen inch diameter intake moves up to 3,000 bu/hr*. There's no replacement for displacement! Walinga's evolved larger displacement dual fan units are designed to meet the increased demands of larger facilities.

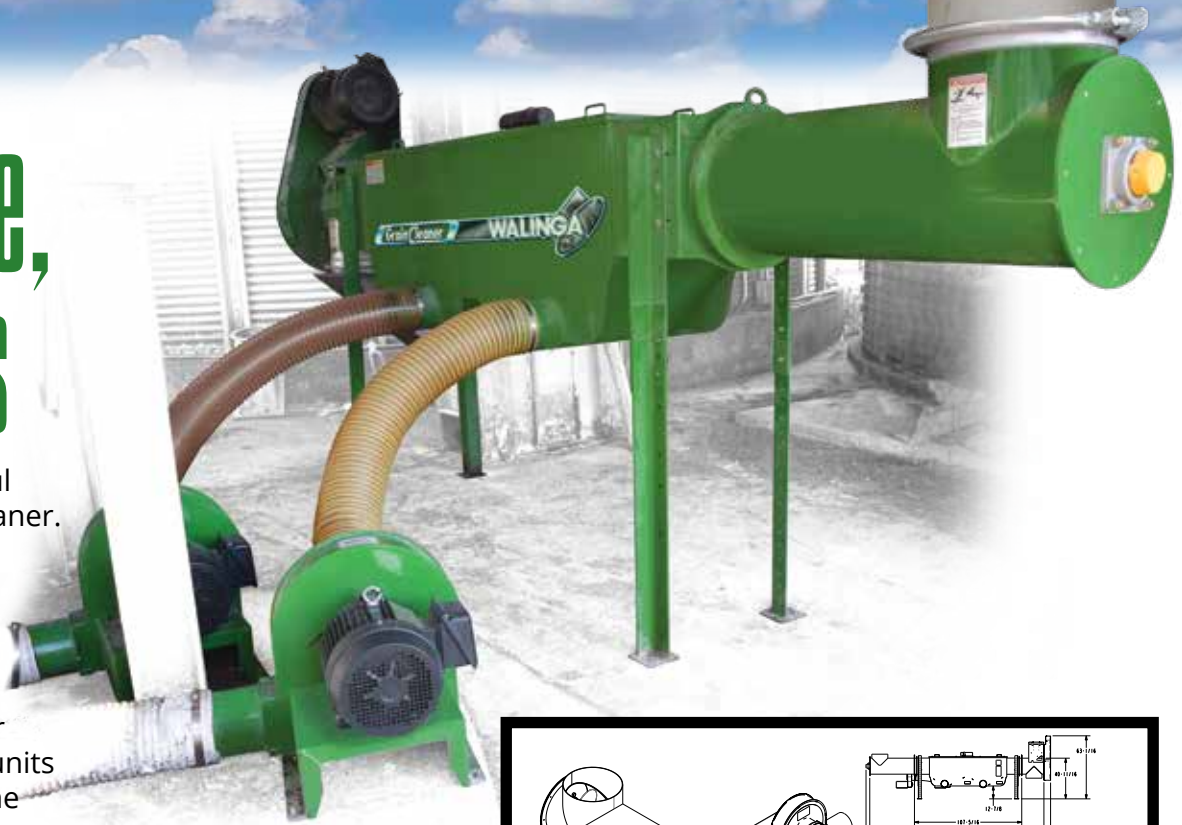

ALL INCLUSIVE TWO YEAR WARRANTY

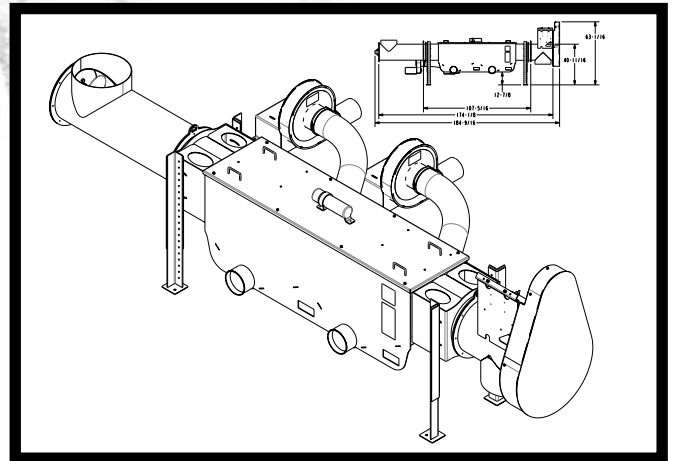

16" SELF CONTAINED UNIT with Dual Fans

Walinga endeavors that new equipment be free from defects in material and workmanship. The warranty period is either two years from purchase or 500 hrs. of operation, whichever occurs first. Full terms and conditions are available from Walinga or your local Walinga dealer.

*Capacities based on moving dry corn. Barometric pressure, humidity, and condition of product will affect capacity. Due to continuous product development specifications may improve.

WALINGA.COM

Head Office

R.R. #5,
Guelph, Ontario
Canada N1H 6J2
Tel: 519.824.8520
Tel: 888.925.4642
Fax: 519.824.5651

Michigan

1190 Electric Ave.
Wayland, Michigan
USA 49348
Tel: 616.877.3470
Tel: 800.466.1197
Fax: 616.877.3474

Manitoba

70 3rd Ave. N.E.
Box 1790
Carman, Manitoba
Canada R0G 0J0
Tel: 204.745.2951
Fax: 204.745.6309

Ontario

938 Glengarry Cres.
Fergus, Ontario
Canada N1M 2W6
Tel: 519.787.VACS (8227)
Fax: 519.787.8210

Australia

Customvac Australia
24 Molloy St.
Toowoomba Qld 4350
Australia
Tel: 1800 242 699

